

John Walker · Joseph L. Awange

Surveying for Civil and Mine Engineers

Theory, Workshops, and Practicals

Surveying for Civil and Mine Engineers

John Walker · Joseph L. Awange

Surveying for Civil and Mine Engineers

Theory, Workshops, and Practicals

 Springer

John Walker
Department of Spatial Science
Curtin University
Bentley, Perth, WA
Australia

Joseph L. Awange
Department of Spatial Science
Curtin University
Bentley, Perth, WA
Australia

ISBN 978-3-319-53128-1 ISBN 978-3-319-53129-8 (eBook)
DOI 10.1007/978-3-319-53129-8

Library of Congress Control Number: 2017936693

© Springer International Publishing AG 2018

This work is subject to copyright. All rights are reserved by the Publisher, whether the whole or part of the material is concerned, specifically the rights of translation, reprinting, reuse of illustrations, recitation, broadcasting, reproduction on microfilms or in any other physical way, and transmission or information storage and retrieval, electronic adaptation, computer software, or by similar or dissimilar methodology now known or hereafter developed.

The use of general descriptive names, registered names, trademarks, service marks, etc. in this publication does not imply, even in the absence of a specific statement, that such names are exempt from the relevant protective laws and regulations and therefore free for general use.

The publisher, the authors and the editors are safe to assume that the advice and information in this book are believed to be true and accurate at the date of publication. Neither the publisher nor the authors or the editors give a warranty, express or implied, with respect to the material contained herein or for any errors or omissions that may have been made. The publisher remains neutral with regard to jurisdictional claims in published maps and institutional affiliations.

Printed on acid-free paper

This Springer imprint is published by Springer Nature
The registered company is Springer International Publishing AG
The registered company address is: Gewerbestrasse 11, 6330 Cham, Switzerland

*This book is dedicated to all civil and mine engineering students
(past and present) of Curtin University, Australia*

Foreword



I am pleased to present a foreword to this book, aimed at explaining surveying methods and practices to Civil and Mining Engineers. The authors have made a sharp distinction between engineering surveying, a profession in its own right, and the surveying knowledge requirements expected of Civil and Mining Engineers. The book is the result of close cooperation between the Departments of Civil Engineering, Mining Engineering, and Spatial Sciences at Curtin University and the University of Western Australia; the course has been presented to undergraduate and postgraduate students over a ten-year period.

Through theory and practice, using lecture material, workshops and practical exercises, the half-semester course provides the Civil and Mining Engineer with an understanding of surveying, enabling an informed discussion with surveyors. Additionally the course promotes and examines practical skills that will enable a Civil or Mining Engineer to perform simple, inexpensive, survey tasks that should be part of an engineer's skill set. The survey ability is also expected by many Civil and Mining Engineering associations, and the course can be proffered by tertiary institutes as an example to professional accreditation bodies.

As Mine Managers, graduate Mining Engineers have a particular responsibility for all surveying on a mine site. This book aims at giving them the ability to examine survey planning and to understand the presented survey result, again through general theoretical knowledge and targeted practical workshops and exercises.

Theory moves from basic plane surveying to geodetic surveying principals, and includes error analysis, coordinate transformation and examples of least squares adjustments. With the increasing sophistication and precision of survey equipment and methods, the engineer has to have a corresponding appreciation of methodologies and results. The ability to move between local coordinate and national grid systems is fundamental to large-scale engineering projects.

Five practical exercises, focus on basic manipulative skill sets and take the student through differential levelling to 3D plane surveying, including coordinate set-out. Corresponding reduction and data interpretation allows the production of earthworks plans and the determination of quantities. DEM production; survey control design and coordinate adjustment illustrate tasks on a small engineering site. A practical examination incorporates circular curve calculation, set-out and quality assurance. The capabilities and limitations of hand-held GPS

receivers in Civil and Mining Engineering are also contrasted with a generous chapter on modern GNSS techniques.

Some of the chapters include information that is missing from standard survey texts; strike and dip analysis from a survey point of view. Calculating inclined angles in mining. Methods of volume determination in road embankments and open pit mines. Circular and transition curves, and superelevation related to a local (Australian) context. Vertical curves related to road design standards. Many of the solved problems are calculated in great detail, allowing the student to use a “follow me” approach to reaching a result.

All calculations can be carried out on simple, non-programmable calculators. Examples of the use of conformal coordinate transformation techniques are expanded from the calculator to spreadsheets (Microsoft Excel) and numerical computing environments (Mathworks MATLAB). Matrix solutions of over-determined resection and trilateration problems are illustrated by example.

The “hands on” approach to the course is designed to provide Civil and Mining Engineers with a knowledge and understanding of surveying techniques that can be applied in discussions with professional surveyors. And allow them to carry out standard survey tasks with confidence.

Prof. Hamid Nikraz FIE (Aust), CPEng, NPER
Professor of Civil Engineering, Curtin University
Perth, Australia

Preface

What's it all about?

The structure of this book is to provide a sequence of theory, workshops and field practical sessions that mimic a simple survey project, designed for civil and mine engineers. The format of the book is based on a number of years of experience gained in presenting the course at undergraduate and postgraduate levels. The course is designed to guide engineers through surveying tasks that the engineering industry feels is necessary for students to have in order to demonstrate competency in surveying techniques such as; data gathering and reduction, and report presentation. The course is not designed to make engineers become surveyors, rather, it is designed to allow an appreciation of the civil and mine engineering surveyor's job. There are many excellent textbooks available on the subject of civil engineering surveying, but they address the surveyor, not the engineer. Hopefully this book will distil many parts of the standard text book. A lot of the material presented is scattered through very disparate sources and has been gathered into this book to show what techniques lie behind a surveyor's repertoire of observational and computational skills, and provide an understanding of the decisions made in terms of the presentation of results. The course has been designed to run over about 6 weeks of a semester, providing a half unit load which complements a computer-aided design (CAD) based design project. The following is an example of a generic course structure.

The Civil Engineer. A role in ambitious construction projects

http://courses.curtin.edu.au/course_overview/undergraduate/civil-engineering

Civil engineers design and construct infrastructure such as:

- bridges
- roads
- harbours
- highways
- dams
- buildings.

As a built environment becomes increasingly complicated, ambitious construction projects are completed by teams of people with different skills, working together. The civil engineer plays an important role in this process.

The Mining Engineer. A stepping stone to Mine Management

http://courses.curtin.edu.au/course_overview/undergraduate/mining-engineering

Mining engineers plan and direct the engineering aspects of extracting mineral resources from the earth.

Mining engineers plan and manage operations to exploit minerals from underground or open-pit mines, safely and efficiently. They design and direct mining operations and infrastructure including:

- drilling
- blasting

- loading and hauling
- tunnel creation and maintenance
- access road planning and maintenance
- water and power supplies.

Mining engineers may supervise other engineers, surveyors, geologists, scientists and technicians working on a mine site and may find employment in metropolitan or regional locations or in different countries.

The tasks with which a mining engineer may be associated include:

- conduct investigations of mineral deposits and undertake evaluations in collaboration with geologists, other earth scientists and economists to determine whether the mineral deposits can be mined profitably
- determine the most suitable method of mining the minerals taking into account factors such as the depth and characteristics of the deposit and its surroundings
- prepare the layout of the mine development and the procedure by which the minerals are to be mined
- prepare plans for mines, including tunnels and shafts for underground operations, and pits and haulage roads for open-cut operations, using computer-aided design (CAD) packages
- plan and coordinate the employment of mining staff and equipment with regard to efficiency, safety and environmental conditions
- talk to geologists and other engineers about the design, selection and provision of machines, facilities and systems for mining, as well as infrastructure such as access roads, water and power supplies
- coordinate with the operations supervisor to make sure there is proper implementation of the plans
- operate computers to assist with calculations, prepare estimates on the cost of the operation and control expenditure when mines begin production
- oversee the construction of the mine and the installation of the plant machinery and equipment
- make sure that mining regulations are observed, including the proper use and care of explosives, and the correct ventilation to allow the removal of dust and gases
- conduct research aimed at improving efficiency and safety in mines
- establish first aid and emergency services facilities at the mines.

In broader terms a qualification in engineering is a prerequisite to an advancement in engineering management. For mining engineers in Western Australia it is a statutory requirement proscribed by Act and regulation (the Mining Act). For civil engineers advancement in management depends on demonstrated competencies in a number of fields; investigation, design, analysis, costing, quantity surveying, tender documentation and presentation, project coordination and management, project delivery, safety and human resource management.

Essentially, engineering is about management of the project and the resulting built environment, about the integration of diverse groups of skilled professionals to achieve a common goal.

Then, “Why Surveying?”

You will have a team of surveyors intimately involved in controlling the placement of your design. They ensure not only adherence to the design dimensions, but also, through licences surveyors, ensure the legal location of the project in terms of cadastral boundaries. Encroachment on another property is an expensive business.

So, “Why Me? Won’t the Surveyor do it?”

Yes, but, sometimes you may need to do a simple task on a small job; check an invert level before a pour, understand the origin of survey data, calculate rough quantities, understand quantities before signing off on invoices, evaluate proposed survey control for a project, check structural setout. All the little things that your industry expects you to be able to do in the field.

As projects become larger and more complex; as surveying becomes more automated both in the field and in the design process; as machine control relies on both terrestrial data and GNSS (GPS) data, the need for basic surveying techniques seems a distant memory. It's not, you still have to understand the basics, and understand positioning from a whole new spectrum of positional precision and accuracy.

Hopefully you will find this course provides that understanding.

John Walker
Curtin University (Australia)

Joseph L. Awange
Curtin University (Australia), Karlsruhe Institute
of Technology (Germany), Kyoto University (Japan) and Federal
University of Pernambuco (Brazil)

Acknowledgements

During the past 10 years of teaching Civil Engineering Drawing and Surveying as well as Mine Surveying and GIS units, we received numerous feedbacks from civil and mine engineering students and staff of Curtin University. In particular, Mr. Tony Snow who has taught engineering surveying and mining units provided some lecture materials portions of which contributed to the contents of the current book. To all the students, staff and Tony, we say “good on you mate”. Joseph wishes to express his sincere thanks to Prof. B. Heck (Karlsruhe Institute of Technology (KIT), Germany) for hosting him during the period of his Alexander von Humboldt Fellowship (June–September 2015), Prof. Y. Fukuda (Kyoto University, Japan) for hosting him during the period of his Japan Society of Promotion of Science (JSPS) Fellowship (October–November 2015), and Prof. R. Goncalves of Federal University of Pernambuco (Brazil) for hosting him during his Science Without Boarder (December 2015–March 2016). Parts of this book were written during these periods. He is also grateful to Prof. B. Veenendaal (Head of Department, Spatial Sciences, Curtin University, Australia) for the support and motivation that enabled the preparation of this edition. He also wishes to acknowledge the support of Alexander von Humboldt that facilitated his stay at KIT, JSPS that supported his stay at Kyoto University, and Capes for supporting his stay in Brazil. To all, he says, “ahsante sana” (Swahili for thank you very much). Special thanks go to his family, namely Mrs Naomi Awange, Lucy Awange and Ruth Awange who had to contend with his long periods of absence from home.

TABLE OF CONTENTS

1	CHAPTER 1 FUNDAMENTAL SURVEYING	1
1.1	INTRODUCTORY REMARKS	1
1.2	DEFINITIONS.....	1
1.2.1	Surveying.....	1
1.2.2	Engineering and Mine Surveying.....	1
1.3	PLANE AND GEODETIC SURVEYING.....	2
1.4	MEASURING TECHNIQUES.....	3
1.4.1	Plane Surveying Measurements and Instruments	3
1.4.2	Geodetic Measuring Techniques.....	4
1.4.3	Basic Measuring Principles and Error Management.....	5
1.5	MEASUREMENT TYPES	6
1.5.2	Linear Measurements	6
1.5.3	Traversing.....	6
1.6	CONCLUDING REMARKS	8
1.7	REFERENCE FOR CHAPTER 1	8
2	CHAPTER 2 LEVELLING.....	9
2.1	INTRODUCTORY REMARKS	9
2.2	DEFINITIONS OF LEVELLING TERMINOLOGIES	9
2.3	EXAMPLE: THE AUSTRALIAN HEIGHT DATUM (AHD).....	10
2.4	INSTRUMENTATION: AUTOMATIC LEVEL AND STAFF	14
2.4.1	Setting the instrument for area levelling.....	14
2.4.2	Levelling the instrument.....	14
2.4.3	Focusing the instrument.....	15
2.4.4	Reading the staff interval.....	15
2.4.5	Collimation checks (Two peg test).....	16
2.5	MEASURING AND REDUCTION TECHNIQUES	18
2.5.1	Basic Rules of Levelling.....	18
2.5.2	Levelling Specifications in Australia	18
2.5.3	Differential Levelling: The “Rise and Fall” method.....	19
2.5.4	Booking and field reduction procedures for levelling.....	19
2.5.5	Rise and Fall Booking and Reduction Procedures.....	20
2.5.6	Area Levelling: The “Rise and Fall” Method.....	21
2.5.7	Area Levelling: The “Height of Collimation” Method	22
2.6	EXAMPLES OF LEVELLING FOR HEIGHT CONTROL	24
2.6.1	Civil Engineering for a Road Excavation Exercise.....	24
2.6.2	Mining Engineering Surveying for a Site Development	25
2.6.3	Grid Layout for levelling	26
2.6.4	Orthogonal Grid Layout Methods.....	27
2.6.5	Height from Vertical Inclination.....	27
2.7	ERRORS IN LEVELLING AND MANAGEMENT STRATEGIES	28
2.7.1	Systematic Errors in Level Observations	28
2.7.2	Random Errors in Level Observations	29
2.7.3	Observation Blunders and Mistakes.....	30
2.8	CONCLUDING REMARKS	30
2.9	REFERENCES TO CHAPTER 2	30

3	CHAPTER 3 RELIEF AND VERTICAL SECTIONS	31
3.1	INTRODUCTORY REMARKS	31
3.2	DEFINITIONS	31
3.3	APPLICATION: ROAD DESIGN.....	34
3.4	CALCULATION OF ROAD CROSS SECTIONS IN CUT AND FILL OPERATIONS.....	35
3.4.1	Calculation of Cut Formation Width w_L , and, w_R , Flat Ground.....	36
3.4.2	Calculation of Formation Width, w_L , and, w_R , Incorporating Cross Fall. Sloping Ground.....	36
3.4.3	Calculation of Formation Width, w_L , and, w_R , Constant Cross Fall Ground	38
3.4.4	Calculation of Formation Width, w_L , and w_R , Varying Cross Fall Ground	38
3.4.5	Batter Width Falls Outside the First Cross Section	39
3.4.6	Derivation of AREA Formula using Formation Widths	40
3.4.7	Area by Matrix Determinant.....	41
3.5	CALCULATION OF EMBANKMENT VOLUME FROM ROAD CROSS SECTIONS IN CUT AND FILL OPERATIONS	42
3.6	PLAN SCALE, HORIZONTAL AND VERTICAL.....	42
3.7	VERTICAL EXAGGERATION.....	43
3.8	PLAN SKETCHING AND DRAWING	43
3.9	CALCULATION OF EMBANKMENT VOLUME FROM BATTER SLOPES: MINING.....	43
3.9.1	Batters, Ramps and Benches.....	43
3.9.2	Calculate Cross Section Areas for Volume: Mining.....	45
3.9.3	Cross Section Area by Trapezium.....	47
3.9.4	Block Volume	48
3.9.5	Volume by Contour	50
3.9.6	Missing Grid Data	51
3.9.7	Stockpile Volumes	52
3.10	CONCLUDING REMARKS	54
3.11	REFERENCE TO CHAPTER 3	54
4	CHAPTER 4 TOTAL STATION: MEASUREMENTS AND COMPUTATIONS	55
4.1	INTRODUCTORY REMARKS	55
4.2	INSTRUMENTATION AND OPERATION	55
4.2.1	The Total Station.....	55
4.2.2	Setting over a Point Using the Optical or Laser Plummet.....	57
4.2.3	Preparing Trimble M3 DR 5” for Survey Observations.....	58
4.2.4	Preparing Sokkia SET530RK3 for Survey Observations.....	58
4.3	MEASUREMENTS	62
4.3.1	Distance Measurements.....	62
4.4	PRISM CONSTANT, WHY ALL THE FUSS?.....	64
4.4.1	How a Prism is Measured, and its PC is Determined.....	64
4.4.2	The Leica Geosystems Total Station Prism Constant Conundrum.....	65
4.5	ANGULAR MEASUREMENTS.....	68
4.6	COMBINED TOTAL STATION MEASUREMENTS	69
4.6.1	Station Records	69
4.6.2	Recording Observations	69
4.6.3	Example Recording of Observations from an Initial Station.....	70
4.7	COMPUTATIONS	70
4.7.1	Manipulating VECTORS	70
4.7.2	Using the POLAR and RECTANGULAR Function on a Calculator	74

4.7.3	Reduction of Electronically Measured Distance to the Spheroid	74
4.8	OBSERVATION BLUNDERS AND MISTAKES	76
4.9	CONCLUDING REMARKS	76
4.10	REFERENCE TO CHAPTER 4	76
5	CHAPTER 5 TRAVERSING	77
5.1	INTRODUCTORY REMARKS	77
5.2	DEFINITION AND APPLICATIONS.....	77
5.3	TRAVERSE PROCEDURE	78
5.4	FIELD NOTES REDUCTION.....	79
5.4.1	Angular Misclose	80
5.4.2	Bearing and Coordinates Computations	81
5.4.3	Traverse Misclose: Bowditch Adjustment.....	81
5.4.4	Area Computations.....	82
5.4.5	Summary of the Traverse Computation	83
5.5	EXAMPLE: SET-OUT AND ADJUSTMENT OF CONTROL POINTS FOR SITE CONTROL.....	83
5.5.1	Field Book Observations and Reduction	84
5.5.2	Network Adjustment Method	85
5.5.3	Angular Misclose Correction.....	86
5.5.4	Adjusted Coordinates using the Bowditch Adjustment	86
5.5.5	Calculation of AREA by Coordinates Method	87
5.5.6	Calculation of Area by Double Longitude Coordinates	88
5.5.7	Example Field Calculations. Field Practical in Appendix A2-3.....	88
5.5.8	The “eccy” Station. Missing the Point?.....	90
5.6	SOURCES OF ERRORS IN TRAVERSING	92
5.7	CONCLUDING REMARKS	92
5.8	REFERENCE FOR CHAPTER 5	92
6	CHAPTER 6 TOTAL STATION DIFFERENTIAL LEVELLING	93
6.1	INTRODUCTORY REMARKS	93
6.2	ERRORS PROPAGATION IN TRIGONOMETRIC LEVELLING	93
6.2.1	Systematic Errors in Level Observations	94
6.2.2	Random Errors in Observations	95
6.3	CALCULATION OF THREE DIMENSIONAL COORDINATES FROM OBSERVATIONS.....	96
6.3.1	Calculation of Observed Distances.	96
6.3.2	Direct Calculation of Horizontal X, Y Coordinates by Intersection of Horizontal Distances to Known Points.....	97
6.3.3	Orientation of a Local Coordinate System to a Grid System	99
6.3.4	Observation, Booking and Calculation of Terrain Points for DTM.....	100
6.3.5	Feature Codes for Point and Line Pickup	101
6.4	CONCLUDING REMARKS.....	101
6.5	REFERENCE TO CHAPTER 6	101
7	CHAPTER 7 STRIKE AND DIP TO AN EMBEDDED PLANE	103
7.1	INTRODUCTORY REMARKS	103
7.2	STRIKE AND DIP	103
7.3	STRIKE AND DIP TO A PLANE	103
7.4	DERIVING STRIKE AND DIP OF A PLANE	103
7.4.1	Strike and Dip of a Plane, a Worked Example by Calculation.....	105
7.4.2	Strike and Dip of a Plane, the Graphical Solution	106
7.4.3	Maximum Dip “Outside” Strike Lines	107

7.5	SEAM THICKNESS.....	108
7.6	DEPTH TO SEAM.....	108
7.7	DIRECTION OF ANY SLOPE OVER THE DIPPING SURFACE.....	109
7.8	HORIZONTAL ANGLES PROJECTED ON TO AN INCLINED PLANE	110
7.8.1	Worked Example 2.....	111
7.8.2	Worked Example 3.....	112
7.9	CONCLUDING REMARKS.....	112
7.10	REFERENCE FOR CHAPTER 7	113
8	CHAPTER 8 CIRCULAR CURVES.....	115
8.1	INTRODUCTORY REMARKS	115
8.2	GENERATING A CIRCULAR CURVE - A PROCESS OF VISUALISATION.....	117
8.2.1	Basic Formulae	117
8.2.2	The Tangent Distance.....	117
8.2.3	The Long Chord.....	118
8.2.4	The Chord Deflection Angle.....	118
8.2.5	Chainage	119
8.2.6	In, Through and Out Arcs. Setout and Checking Tools	121
8.2.7	Calculating a Circular Curve: Definitions and Formulæ.....	122
8.3	LAYING OUT OF CIRCULAR CURVES	122
8.4	CALCULATIONS FOR A FIELD PRACTICAL EXERCISE	124
8.4.1	Calculation of a Design Curve.....	124
8.4.2	Curve Radius from Design Profile.....	124
8.4.3	Initial Curve Calculations	126
8.4.4	In, Through and Out arcs for Curve M1	127
8.5	ROADS IN MINING OPERATIONS.....	127
8.5.1	Haul Road Example.....	127
8.5.2	Curve T5, centre line calculations.....	127
8.6	CONCLUDING REMARKS.....	128
8.7	REFERENCES TO CHAPTER 8	129
9	CHAPTER 9 VERTICAL CURVES.....	131
9.1	INTRODUCTORY REMARKS	131
9.1.1	Definition.....	131
9.1.2	Uses	131
9.1.3	Components of a Vertical Curve.....	131
9.2	ELEMENTS OF THE VERTICAL CURVE.....	132
9.2.1	Sign of r.	133
9.3	CALCULUS OF THE PARABOLA	134
9.3.1	Developing the General Equation	134
9.3.2	Deriving Data from the General Equation.....	134
9.3.3	High or Low Point of the Vertical Curve	135
9.3.4	Level of High or Low Point of the Vertical Curve	135
9.3.5	The Midpoint of the Vertical Curve	136
9.3.6	Pass a Curve Through a Fixed Point	138
9.4	CALCULATE THE RLS OF POINTS ALONG THE VERTICAL CURVE.....	139
9.4.1	Worked Example. Single Vertical Curve	139
9.4.2	Worked Example. Multiple Vertical Curves	141
9.4.3	Vertical Curves in Rural Road Design.....	142
9.4.4	Grades in Rural Road Design	143
9.4.5	Length of Vertical Curves in Rural Road Design	144

9.4.6	“K” Value in Vertical Curve Design.....	144
9.4.7	Sight Distance in Vertical Curve Design.....	144
9.4.8	The Arc Length of the Vertical Curve.....	145
9.5	CONCLUDING REMARKS.....	145
9.6	REFERENCES FOR CHAPTER 9.....	145
10	CHAPTER 10 GLOBAL NAVIGATION SATELLITE SYSTEM	147
10.1	INTRODUCTORY REMARKS	147
10.2	GNSS, A REVOLUTION TO MINE AND CIVIL ENGINEERING INDUSTRIES.....	148
10.2.1	Measuring principle and GNSS Family	148
10.2.2	Applications to Mine and Civil Engineering Operations	148
10.3	GPS DESIGN AND OPERATION	149
10.3.1	Space Segment	149
10.3.2	Control Segment.....	150
10.3.3	User Segment	151
10.4	ERRORS IN GPS MEASUREMENTS	151
10.4.1	Ephemeris Errors.....	151
10.4.2	Clock Errors.....	152
10.4.3	Atmospheric Errors	152
10.4.4	Multipath.....	154
10.4.5	Satellite Constellation “Geometry”	154
10.4.6	Other Sources of Errors.....	155
10.5	CONCLUDING REMARKS.....	155
10.6	REFERENCE TO CHAPTER 10	155
11	CHAPTER 11 SETTING OUT OF ENGINEERING STRUCTURES	157
11.1	INTRODUCTORY REMARKS	157
11.2	CONTROL SURVEYING.....	158
11.3	UNDERTAKING AN ENGINEERING CONSTRUCTION PROJECT.....	159
11.3.1	Personnel involved	159
11.3.2	Recording and Filing of Information.....	159
11.3.3	Plans	159
11.3.4	Setting out Methods and Procedures.....	160
11.4	CONCLUDING REMARKS.....	167
11.5	REFERENCES TO CHAPTER 11	167
12	CHAPTER 12 COORDINATE TRANSFORMATION AND LEAST SQUARES SOLUTIONS.....	169
12.1	INTRODUCTION	169
12.2	DEFINITIONS	169
12.3	TRANSFORMATION METHODS.....	171
12.3.1	Block shift.....	171
12.3.2	Conformal transformation	172
12.3.3	A Matrix Method Approach to Coordinate Transformations - the Unique Solution.....	178
12.3.4	Least Squares Solution to Coordinate Transformation	181
12.4	COORDINATE TRANSLATIONS – A VERY HELPFUL TECHNIQUE.....	185
12.5	RESECTION TO A POINT BY EDM – A LEAST SQUARES SOLUTION	186
12.5.1	Resection by Observation from an Unknown Point to Two Known Points	187
12.6	LEAST SQUARES SOLUTION OF AN OVER-DETERMINED TRILATERATION PROBLEM.....	191

12.7	CONCLUDING REMARKS	195
12.8	REFERENCES TO CHAPTER 12	195
13	APPENDICES.....	197
A1	WORKSHOP MATERIALS	197
A1-1	WORKSHOP 1 - LEVELLING	197
A1-2	WORKSHOP 2 – EARTHWORKS: RELIEF REPRESENTATION AND VERTICAL SECTIONS	200
A1-3	WORKSHOP 3 – TOTAL STATION AND ANGULAR MEASUREMENTS	201
A1-4	WORKSHOP 4 – TRAVERSING	203
A1-5	WORKSHOP 5 – HORIZONTAL CURVES	204
A2	FIELD PRACTICAL MATERIALS.....	205
A2-1	INSTRUCTIONS FOR FIELD PRACTICAL SESSIONS.....	205
A2-1-1	INTRODUCTORY REMARKS	205
A2-1-2	CONDUCT OF FIELD PRACTICAL SESSIONS.....	205
A2-1-3	FIELD CHECKS	206
A2-1-4	COMPUTATIONS AND PLAN DRAWINGS	206
A2-1-5	EQUIPMENT.....	207
A2-1-6	HYGIENE, SAFETY AND DRESS.....	207
A2-1-7	WORKSHOPS	207
A2-1-8	FIELD PRACTICAL INSTRUCTIONS	207
A2-1-9	FIELD BOOKS AND DATA RECORDING.....	207
A2-2	ESTABLISHMENT OF VERTICAL CONTROL AND VERTICAL SECTIONS FOR A CONSTRUCTION SITE	208
A2-2-1	FIELD PRACTICAL 1: ESTABLISHMENT OF VERTICAL CONTROL.....	208
A2-2-2	FIELD PRACTICAL 2: VERTICAL SECTIONS.....	210
A2-3	ESTABLISHMENT OF HORIZONTAL CONTROL FOR A CONSTRUCTION SITE.....	219
A2-3-1	FIELD PRACTICAL 3: ESTABLISHMENT OF HORIZONTAL CONTROL	219
A2-3-2	FIELD PRACTICAL 4: ESTABLISHMENT AND ADJUSTMENT OF CONSTRUCTION SITE BOUNDARY CONTROL	223
A2-4	ESTABLISHMENT OF HORIZONTAL CURVES FIELD EXAMINATION.....	229
A2-4-1	CALCULATION AND SET-OUT OF A SIMPLE CURVE—ASSESSED FIELD PRACTICAL 5.....	229
A2-4-2	LOCATION OF FIELD WORK: EDINBURGH OVAL SOUTH.....	231
A2-4-3	CURVE SET-OUT DATA	232
A2-4-4	CURVE COORDINATE DATA FOR EACH GROUP	233
A2-4-5	CURVE CHECK OBSERVATIONS.....	234
A2-4-6	EXAMPLE GROUP ASSESSMENT FORM.....	235
A2-4-7	DEFINITIONS AND FORMULAE.....	236
A2-5	COMPUTATION OF DESIGN PARAMETERS OF VERTICAL CURVES	238
A2-5-1	PRACTICAL 6.....	238
A2-5-2	TASK:	238
A2-6	EXAMPLES OF INTERIM REPORTS	242
A3	CIVIL ENGINEERS PRACTICALS	243
A3-1	CIVIL ENGINEERS PRACTICALS 1	243
A3-2	CIVIL ENGINEERS PRACTICAL 2	244
A3-3	CIVIL ENGINEERS PRACTICAL 3	245
A3-4	CIVIL ENGINEERS PRACTICAL 4	246
A4	MINING ENGINEERS PRACTICALS.....	247
A4-1	MINING ENGINEERS PRACTICAL 1.....	247

A4-2	MINING ENGINEERS PRACTICAL 2.....	248
A4-3	MINING ENGINEERS PRACTICAL 3.....	249
A4-4	MINING ENGINEERS PRACTICAL 4.....	250
A4-5	CIVIL AND MINING ENGINEERS. PRACTICAL 5	251
A5	SURVEY CALCULATIONS ON THE HP 10S+	252
A5-1	INTRODUCTION	252
A5-1-1	SET-UP FOR SURVEYING.....	252
A5-1-2	TIME/ANGLE CALCULATIONS:	252
A5-1-3	DMS TO DECIMAL DEGREES: ON ANS LINE.	252
A5-1-4	DEGREES TO RADIANS:.....	252
A5-1-5	WHY RADIANS TO DEGREES?	253
A5-2	VECTOR CONVERSION AND AXES ROTATION.....	253
A5-2-1	THEM (THE US) AND US (AUSTRALIA).....	254
A5-2-2	THE IMPORTANCE OF THE SIGN OF THE RECTANGULAR COORDINATES	254
A5-3	CONVERTING BETWEEN POLAR AND RECTANGULAR COORDINATES USING FUNCTION KEYS.....	254
A5-3-1	TRIGONOMETRIC CONVERSION TO RECTANGULAR COORDINATES.....	254
A5-3-2	TRIGONOMETRIC CONVERSION USING THE REC() FUNCTION KEY	254
A5-4	CONVERTING BETWEEN RECTANGULAR AND POLAR COORDINATES USING FUNCTION KEYS.....	255
A5-4-1	TRIGONOMETRIC CONVERSION TO POLAR COORDINATES	255
A5-4-2	TRIGONOMETRIC CONVERSION USING THE POL() FUNCTION KEY	256
A5-4-3	THE ATAN2() FUNCTION IN SPREADSHEETS.....	256
A5-5	USING THE M+ KEY FOR ACCUMULATE OPERATIONS	256
A5-6	STATISTICS, MEAN AND STANDARD DEVIATIONS	257
A5-7	CONCLUDING REMARKS.....	257
A5-8	REFERENCES APPENDIX A5	257
14	INDEX.....	259

Chapter 1 Fundamental Surveying

1.1 Introductory Remarks

“Indeed, the most important part of engineering work—and also of other scientific work—is the determination of the method of attacking the problem, whatever it may be, whether an experimental investigation, or a theoretical calculation. ... It is by the choice of a suitable method of attack, that intricate problems are reduced to simple phenomena, and then easily solved.” Charles Proteus Steinmetz.

This chapter introduces the basics of surveying that will be covered in the book. The aim of the chapter is such that once a civil or mine engineering student has covered it and undertaken the necessary workshop, they should:

- ✓ Be able to define surveying.
- ✓ Know various types of surveying.
- ✓ Be able to classify errors in surveying.
- ✓ Know the basic rules of recording field notes.
- ✓ Recognize instrumentation relevant for undertaking engineering surveys.
- ✓ Know the fundamental trigonometrical formulae used in surveying.

More details can be found in Uren and Price (2010, Chapter 1) and Awange and Kiema (2013, Chapter 3).

1.2 Definitions

1.2.1 Surveying

Surveying is traditionally defined as the determination of the location of points on or near the Earth’s surface. A more modern definition is *“the collection, processing, and management of spatial information”*. (Uren and Price 2010). Surveying is important for numerous applications that includes, e.g. land ownership, engineering, mining, marine navigation, mapping and many more.

1.2.2 Engineering and Mine Surveying

Engineering surveying is that branch of surveying that deals mainly with construction, deformation monitoring, industrial and built environment (see Figure 1.1) whereas Mine surveying is undertaken to support mining activities through provision of control points for mining locations. These controls are used for infrastructure construction and also for coordination of points within the mining areas. Besides engineering and mine surveying, other types of surveying include:

- Cadastral surveying, which deals with property boundary determination. Whether for property ownership or development of land, knowledge of who owns what property will always be required.
- Topographic surveying, which deals with the generation of maps at various scales. These maps support variety of uses, ranging from reconnaissance to assisting flood management in civil engineering, for exploration and rescue purposes in mining, mapping spatially changing features, e.g., changes in wetland perimeter in environmental monitoring, to soil type maps for assisting land management decisions. Chapter 4 explores the role of topographical maps in detail.
- Photogrammetric surveying, which uses photogrammetric technology for mapping purposes.

- Control surveying, which is performed to provide horizontal and vertical controls. These in turn provide a framework upon which subsequent locations are based. This type of surveying is more accurately undertaken than the other types of survey and often involves use of more precise equipment.
- Hydrographic surveying, which is undertaken for marine purposes and could also find use in measuring changes in sea level. This is a vital indicator for monitoring the impact of climate change.
- Satellite surveying (see e.g., Seeber 2003). Although this can be undertaken locally to support development activities, its functions are globally oriented and will be discussed in detail in the Chapter 10.
- Inertial surveying systems, which consist of three accelerometers that are orthogonally mounted in known directions, relative to inertial space, on a stable platform used to measure changes in the three-dimensional position, as well as, the length and direction of the gravity vector (Cross 1985). An in-depth exposition of this system is presented, e.g., by Cross 1985 who list the advantages of the system as being faster, independent of refraction of the measuring signals, and independent of external organization unlike the global navigation satellite system (GNSS) discussed in Chapter 10 (see e.g., Awange 2012). Like GNSS, the systems are all-weather and all-day but are expensive to purchase, and can only be used in interpolative mode (Cross 1985). Its usage includes (Cross 1985): provision of photogrammetric control, densification of national control networks, route surveys e.g., for pipelines, powerlines and roads, cadastral surveys, fixing of navigation aids and geophysical surveys. For geophysical surveys, an immediate application that would support mining activities is the measurement of gravity. In some remote-sensing activities, it can give information about the position and attitude of the sensors and it can be combined with a satellite navigation system to give real-time positions offshore (Cross 1985).

1.3 Plane and Geodetic Surveying

The definition of surveying given in Section 1.1 is achieved through distances and angular measurements, which are converted into coordinates to indicate the horizontal position, while heights are measured relative to a given reference, i.e., the vertical dimension.

Surveying plays a pivotal role in determining land ownership, engineering, mapping, marine navigation, and environmental monitoring through height determination of anthropogenic land subsidence among other uses. For example, surveying plays a crucial role in monitoring deformation of structures such as dams, bridges, buildings and many others. The main strength of surveying is that it operates locally, at levels by which most development activities take place.

Surveying can take on the form of plane surveying, where a flat horizontal surface is used to define the local surface of the Earth and the vertical is taken to be perpendicular to this surface (Figure 1.1). Plane surveying, therefore, adopts a horizontal plane as a computational reference and the vertical direction is defined by the local gravity vector, which is considered constant. All measured angles are plane angles, and the method is applicable for areas of limited size. In contrast to plane surveying, *geodetic surveying* uses a curved surface of the Earth as the computational reference, e.g., an ellipsoid of revolution (Figure 1.2). The ellipsoid of revolution is considered to approximate the figure of the Earth, and forms the surface upon which GNSS positioning (Chapter 10) is undertaken. Both could be used for civil and mine engineering at local scale (plane surveying) and global or regional scale (geodetic surveying) as will be discussed in subsequent chapters.

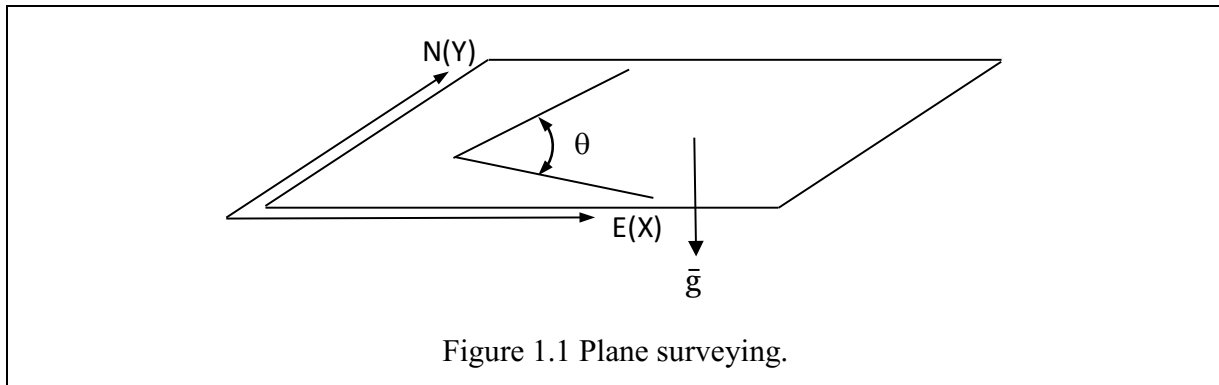

Geodetic surveying, Figure 1.2, is based on the ellipsoid of revolution with a and b being the semi-major and semi-minor axes of the ellipsoid respectively. The position of a point on the reference ellipsoid will be defined by the latitude ϕ , longitude λ , and height h .

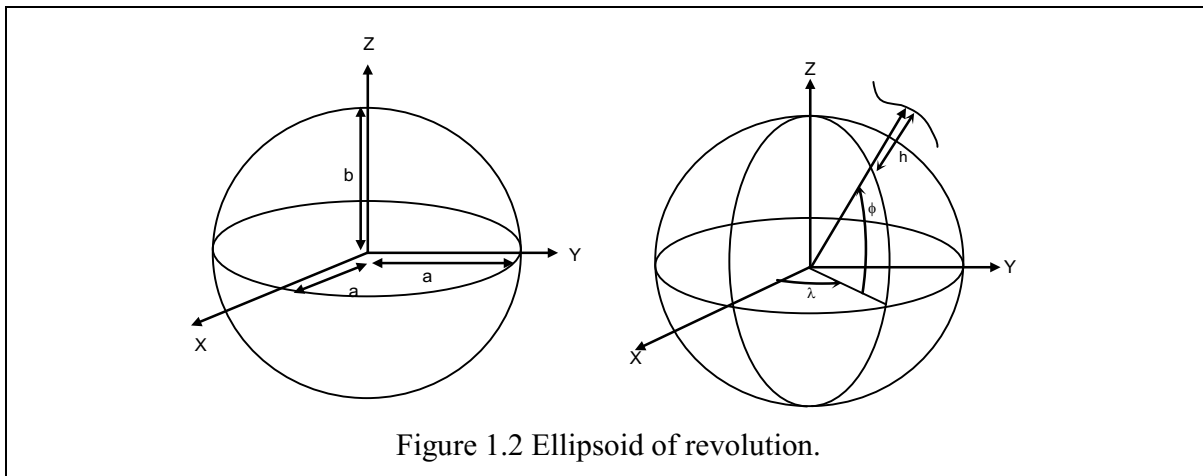

The distinction between plane and geodetic surveying, therefore, is that plane surveying assumes a flat horizontal surface of the Earth where the vertical is considered to be perpendicular to this surface. Geodetic surveying on the other hand accounts for the true form of the Earth as illustrated in Figure 1.2.

1.4 Measuring Techniques

1.4.1 Plane Surveying Measurements and Instruments

Plane surveying measures linear and angular quantities (Figure 1.3). Linear measurements take the form of horizontal distances, e.g., measured directly by a level or indirectly using a Total Station. In measuring horizontal or slope distances with a Total Station (Figure 1.4), use is made of electromagnetic distance measurement (EDM, Uren and Price 2010). Indirect measurement of height differences (vertical distance) using a Total Station instrument makes use of the slope distance and elevation or vertical angle. Height differences are directly measurable using a level (Figure 1.5).

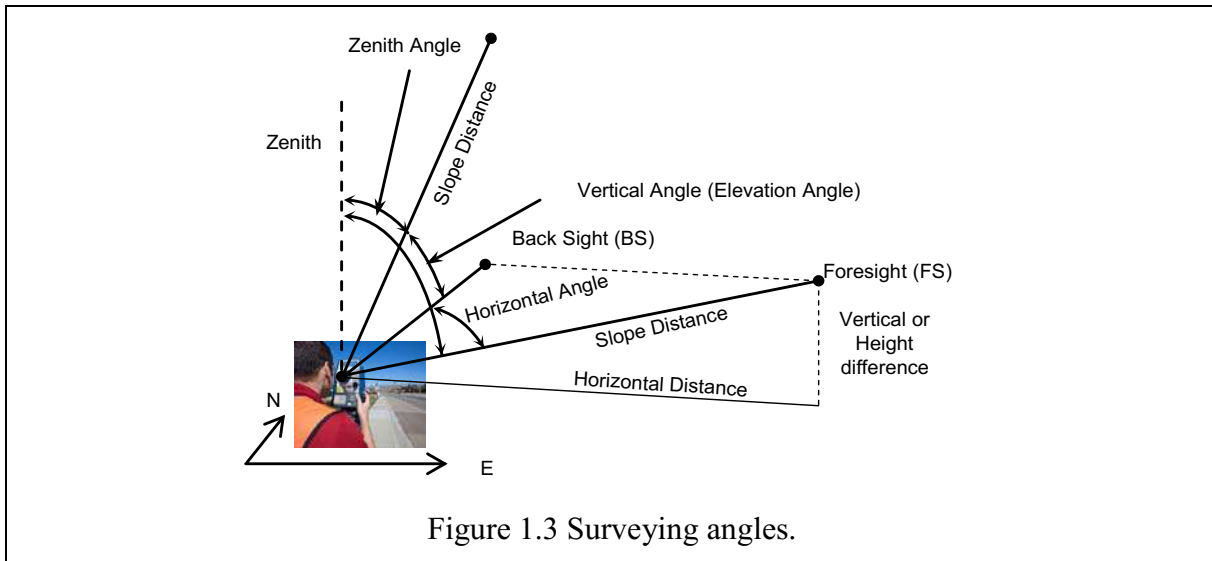

Angular measurements are of three types; vertical or elevation angles, zenith angles, and horizontal angles (Figure 1.3). Vertical or elevation angle to a point is measured with reference to a horizontal plane while the zenith angle is measured with respect to the zenith or vertical direction, where the vertical angle α is given as

$$\alpha = 90^\circ - z,$$

and z is the zenith angle. The horizontal angle is obtained in a horizontal plane by taking the difference between two directions. A Total Station is used to measure the angles discussed above. One can view a Total Station as made of two protractors. A 360° protractor marked in degrees placed in the horizontal plane and used to measure the horizontal angles, and a half circle protractor in the vertical plane used to measure the vertical/zenith angles (Figure 1.6).

1.4.2 Geodetic Measuring Techniques

For geodetic surveying, measurement methods that cover wider spatial extent such as regions, continental or the entire globe are essential. Such methods are useful for large scale engineering projects such as inter-city highway construction. They include but are not limited to global positioning methods, e.g., by Global Navigation Satellite Systems (GNSS) discussed in Chapter 10 (see also Awange 2012), Satellite altimetric methods, Satellite Laser Ranging (SLR) and Lunar Laser Ranging, Interferometric Synthetic Aperture Radar (InSAR), and Very Long Baseline Interferometry (VLBI).

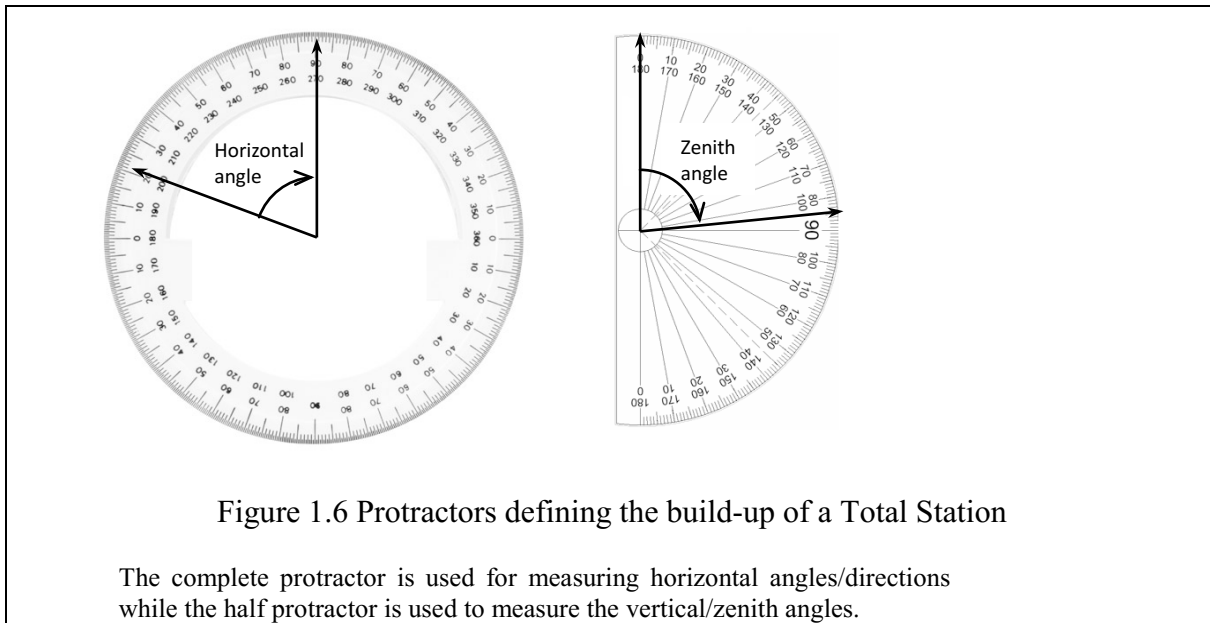

1.4.3 Basic Measuring Principles and Error Management

In surveying, as well as geodesy, there are basic measuring principles that must be adhered to in order to achieve the desired outcome that satisfy both the client and the operator (surveyor). These include completing the measuring task within the shortest possible time and at the least possible cost. This may be beneficial to engineering projects whose monetary budget for excavation is limited. Further, the task must be completed according to instructions and using instruments of appropriate precision. The records of the field notes are essential and form part of legal evidence in a court of law in case of disputes. The following should be taken into consideration.

- ✓ Field notes are permanent records of work done in the field and must be thorough, neat, accurate and guarded carefully.
- ✓ Mistakes in field books are never erased but crossed out with one horizontal line through the middle.
- ✓ Specific field note formats exist for different types of surveys. This is particularly important for cadastral surveys, where notes may be used as evidence in court cases.

Finally, for mitigation and management purposes, in order to achieve accurate results, types of errors in surveying measurements and their sources that should be taken care of include:

- Natural
 - Due to the medium in which observations are made.
 - Factors: Wind, temperature, humidity, etc.
- Instrumental
 - Due to imperfections in instrument construction or adjustment.
 - May be reduced or eliminated by calibration and/or observation procedure.
- Personal
 - Limitations in operator ability.
 - Can be improved with practice.
 - Examples: Ability to read vernier scale, ability to accurately point cross-hairs, etc.
- Mistakes, also called gross errors or blunders.
 - Usually, but not always, large magnitude.

- Examples: Reading a tape incorrectly, transposing numbers, i.e., A distance of 15.369m is read while 15.396m is recorded in the field book.
- Systematic (deterministic) errors
 - Errors that follow some physical or geometric law.
 - Their effects can be mathematically modelled and, thus, corrected.
 - Examples: Refraction of the line of sight, thermal expansion of a steel band.
- Random errors (what is left over)
 - Errors that can't be modelled and corrected: random variations.
 - Governed by probabilistic or stochastic models.

1.5 Measurement Types

1.5.1 Linear Measurements

Linear measurements deal with distances (slope, horizontal or vertical), which are normally required for plotting the positions of details when mapping and also for scales of the maps (see Chapter 4). Horizontal and vertical distances are useful for mapping, provision of controls, and monitoring spatial and vertical changes of features. Slopes and vertical distances are essential for setting out construction structures, where vertical distances are useful in height transfer from floor to floor in multistorey building or in mining, i.e., transferring distances from the surface to underground.

Distance measurements can be undertaken using, e.g., tapes (for short distances) or electromagnetic distance measuring (EDM). Errors associated with tape measurements include instrumental errors (e.g., incorrect length where the tape is either too short or too long), natural errors (e.g., the expansion or contraction of the steel tape caused by temperature changes) or personal errors such as wrong reading of the tape or poor alignment while measuring the distances. EDM is nowadays the most common tool used for measuring distances. It can be classified according to either radiation source (optical or microwave), measurement principle (phase or pulse), or whether a reflector is required or not (i.e., reflectorless). The operating principle involves the signal being emitted from the Total Station to some reflector, which reflects the signals back to the emitter. The distance is then obtained from the basic equation:

$$speed = \frac{Distance}{time},$$

since the speed of light c is known, and the time the signal takes to travel from the emitter and back is measured, say Δt , the distance measured by the EDM instrument then becomes:

$$d = \frac{c\Delta t}{2}.$$

The division by 2 is because the signal travels twice the distance (i.e., from the emitter to the reflector and back). The phase method, where the signal travels in a sinusoidal form is the most common method of distance measurement found in surveying instruments. However, the pulse method using pulsed laser is becoming more common particularly for reflectorless instruments. Errors associated with EDM are elaborately discussed, e.g., in Uren and Price (2010).

1.5.2 Traversing

Traversing, which is covered in detail in Chapter 5, is a survey technique used to determine the planar positions (Easting and Northing: E_B and N_B , Figure 1.7) of control points or setting out points using measured angle θ_{AB} and distance D_{AB} (Fig. 1.6). The position of point B obtained relative to that of A is given as:

$$\Delta E_{AB} = E_B - E_A = D_{AB} \sin \theta_{AB}$$

$$\Delta N_{AB} = N_B - N_A = D_{AB} \cos \theta_{AB}$$

where E_A and N_A is the known planar position of point A .

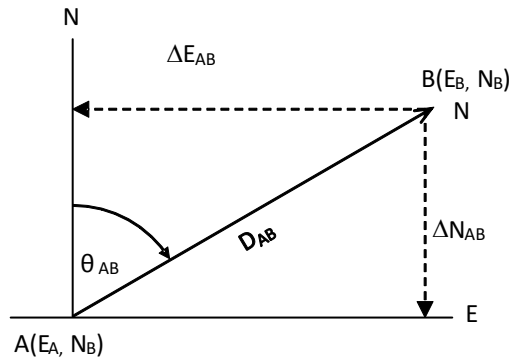

Figure 1.7 Traversing

D_{AB} is the distance between points A and B , while θ_{AB} is the angle measured from the true North from point A to point B .

Applications of traversing include the establishing of control points useful for construction purposes or for delineating feature boundaries, horizontal control for generation of topographic maps (see e.g., Chap. 4) and also for detail maps for engineering works, establishment of planar positions of points during construction (set-out), for area and volume computations, and ground control needed for photogrammetric mapping discussed in Section 1.2.2.

A traverse can take the form of either open or closed. A closed route can start from a known point and end at another known point (e.g., from A to B in Figure 1.8). This type of traverse is also known as link traverse. If the traverse starts from a known point and closes at the same point, then it is known as a loop traverse. An open traverse starts from a known point but does not end at a known point in Figure 1.9.

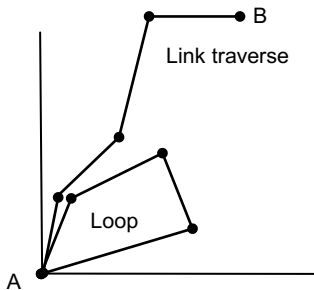

Figure 1.8 Closed traverse.

Closed traverse starts from a known point and ends at another known station.

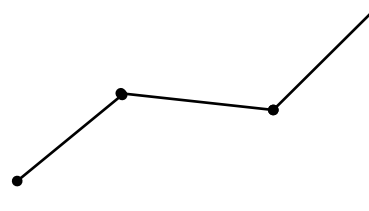

Figure 1.9 Open traverse.

Open traverse may start from an unknown point and ends at another unknown station

1.6 Concluding Remarks

Most of the details covered in this introductory Chapter will be expounded in subsequent chapters. Of importance is that the students should know the purpose of surveying for civil and mine engineering, types of measurements, and errors that underpin these measurements.

1.7 Reference for Chapter 1

1. Awange JL (2012) Environmental monitoring using GNSS, global navigation satellite system, Springer, Berlin.
2. Awange JL and Kiema JBK (2013) Environmental Geoinformatics, Springer, Berlin.
3. Cross PA (1985) Inertial surveying: principles, methods and accuracy. *International Journal of Remote Sensing* 6(10): 1585-1598.
4. Seeber, G (2003) *Satellite geodesy*. Berlin New York, Walter de Gruyter. ISBN 978-3-11-017549-3.
5. Uren J, Price WF (2010) *Surveying for Engineers*. Palgrave Macmillan Ltd. pp. 816.

Chapter 2 Levelling

2.1 Introductory Remarks

This Chapter introduces you to the theory and practical skills of levelling, a process of determining elevations (heights) or differences in elevations. It can be performed using either differential levelling using a level (discussed in this Chapter) or trigonometric levelling using a Total Station (discussed in Chapter 6). Levelling can be used in all aspects of surveying. Particularly for engineering and mining, levelling finds use in:

- ✓ Establishing vertical controls.
- ✓ To establish heights of points during constructions.
- ✓ Route surveys.
- ✓ For contouring purposes.
- ✓ For road cross-sections or volumes of earthwork in civil engineering works.
- ✓ For provision of levels of inclined surface during construction.
- ✓ For designing decline box cut in mining amongst other tasks, e.g., rescuing.

In Chapter 3 where we discuss the representation of relief and vertical sections, you will employ the skills of levelling that you will have learnt in this Chapter. Working through the materials of this Chapter and the workshop materials in Appendix A1-1, you should:

1. Be able to differentiate between heights, datum and bench marks (BM).
2. Know and understand the use of the levelling equipment.
3. Understand the field procedures for levelling.
4. Be able to calculate reduced levels (RL).
5. Know sources of errors in levelling and how to manage them.
6. Know the various levelling methods.

Essential references include, e.g., Uren and Price (2010), Schofield and Breach (2007), and Irvine and Maclellan (2006).

2.2 Definitions of Levelling Terminologies

- Level surface (see Figure 2.1).
 - A (curved) surface orthogonal to the plumb line everywhere.
 - More correctly an equipotential surface for which gravitational potential is constant.
 - A still body of water unaffected by tides is a good analogy.
 - They are not equidistant apart, but converge and diverge due to changes in density.
- Vertical line (see Figure 2.1 and Figure 2.2).
 - The direction of gravity.
 - Therefore, the direction indicated by a plumb line.
 - In general, it deviates from a line emanating from the geometric centre of the Earth.
 - In reality it is curved, but this can be neglected in small plane surveys.
- Horizontal plane (see Figure 2.2).
 - A plane tangent to a level surface (orthogonal to the plumb line).
 - The collimation axis (line of sight) of a levelling instrument that is in correct adjustment. Once levelled, it defines a horizontal plane as the instrument is rotated.
- Vertical datum.
 - Any level surface to which heights are referenced.
 - The vertical datum in Australia is the Australian Height Datum (AHD).
- Mean Sea Level (MSL).
 - Mean height of ocean level taken with data from coastal tide gauges over a 19-year period.

- 30 tide gauges used in Australia.
- 97 230 km of two-way levelling used with the tide gauge data to define the AHD.
- Tidal datum.
 - Average of all high waters observed over a 19-year period.
 - Mean high water (MHW).
- Elevation.
 - The vertical distance (height) above the datum.
- Bench mark (BM).
 - A permanent monument or feature for which elevation is known.
 - Vertical control.
 - A set of benchmarks used to “control the heights” of a project.

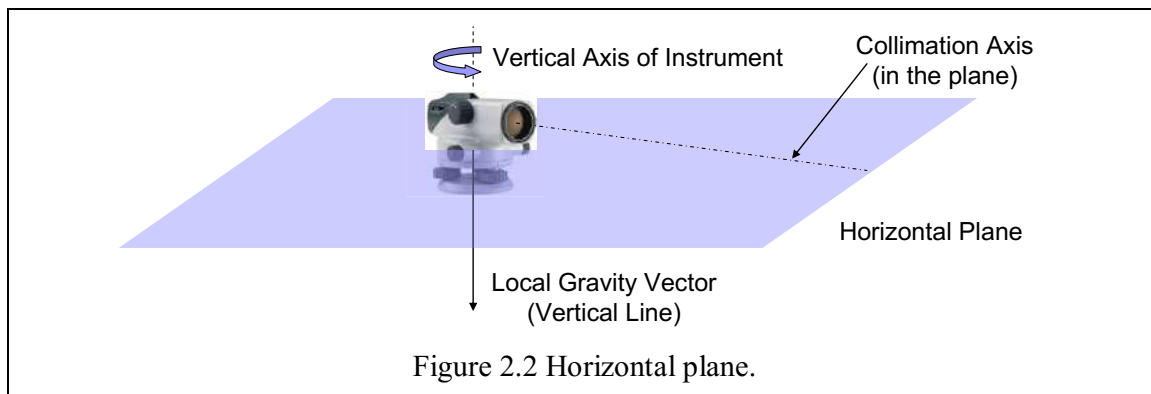
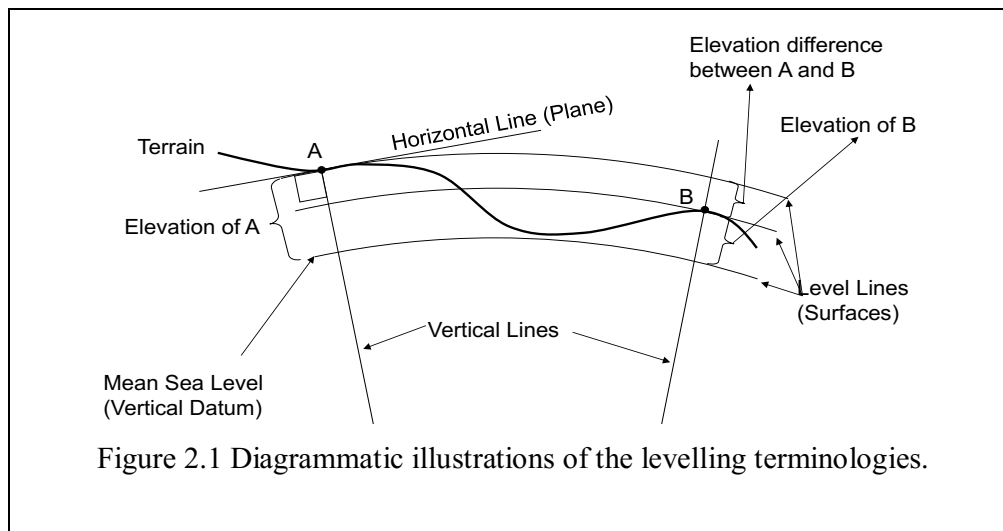

2.3 Example: The Australian Height Datum (AHD)

Heights in Australia are referenced to the Australian Height Datum (AHD) defined as mean sea level at 30 tide gauges around Australia, observed between 1966 and 1968 (Figure 2.3).

Height control is established by **Bench Marks**, vertical control points tied to the AHD by differential levelling. The AHD, almost coincident with the geoid (an equipotential surface approximating the mean sea level), varies from the ellipsoid, the idealised mathematical shape of the Earth by a geoid-ellipsoid separation, N . The AHD N value is modelled to an accuracy of about 0.03m over Australia (Figure 2.4). The difference between the geoid and the AHD is due to the difference in water density between Northern and Southern Australia and accounts for a tilt of $\pm 0.5\text{m}$.

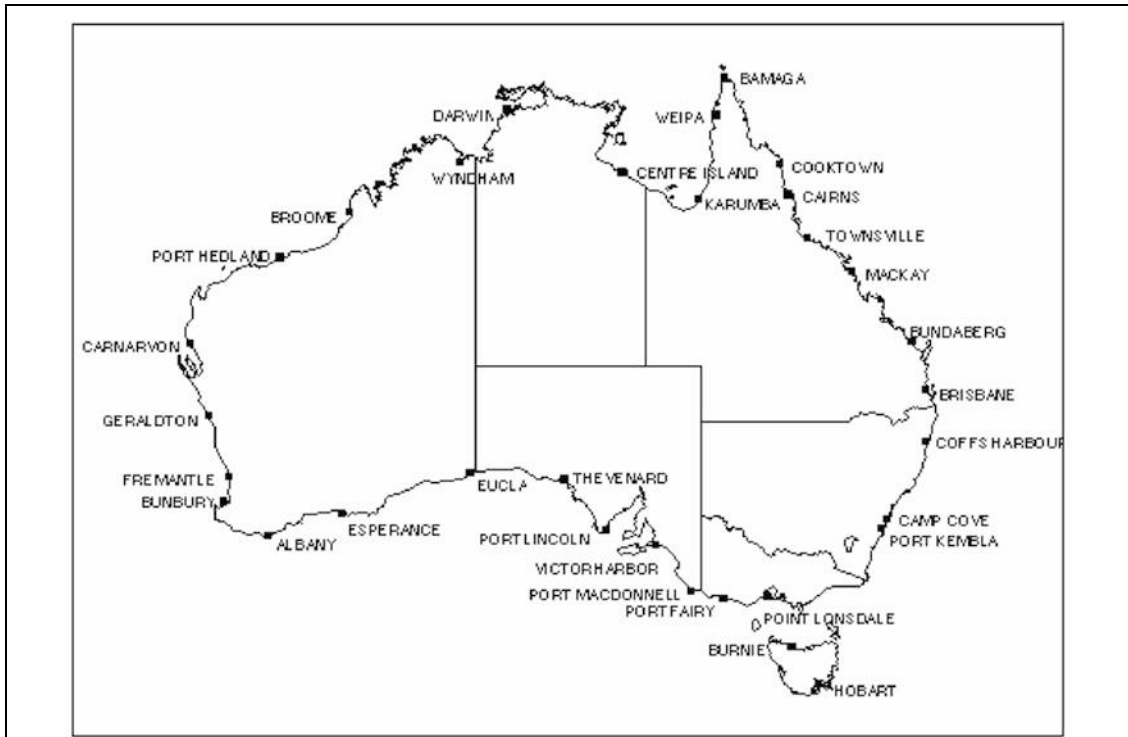

Figure 2.3 Map of tide gauges in Australia. Image source: Geoscience Australia

<http://www.ga.gov.au/geodesy/datums/ahd.jsp>

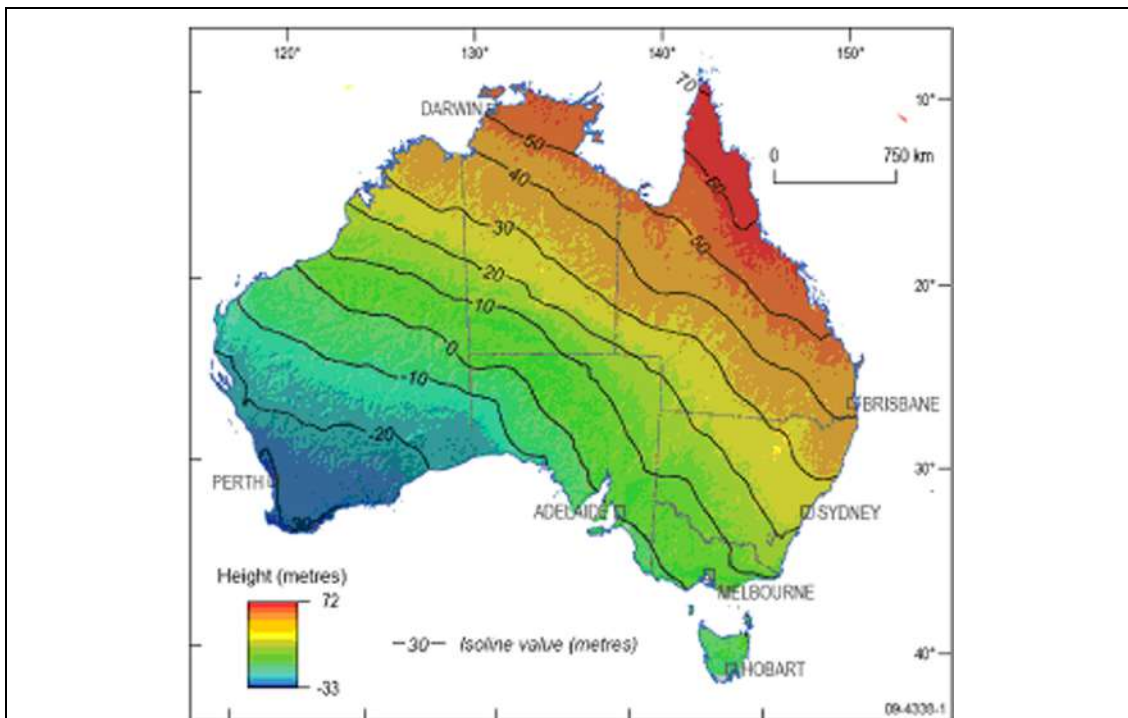

Figure 2.4 Ausgeoid09 – GDA94 separation, N , across Australia. $AHD = H_{GDA94} - N$

(see, e.g., <http://www.ga.gov.au/scientific-topics/positioning-navigation/geodesy/geodetic-datums/geoid>).

The important point to remember is that GPS/GNSS heights (see Chapter 10) refer to the **ellipsoid** and differential levelling heights refer to the **geoid**. Thus, any GPS/GNSS height must be corrected to the AHD by the separation value, N , before using GNSS derived vertical control. The current model of the AHD/geoid separation is Ausgeoid09, which is an upgrade from the original Ausgeoid98 (Featherstone et al. 2001). Illustrated in Figure 2.4 are the 10m isobaths of AHD and Geodetic Datum Australia (GDA94) separation over the AHD model area (<http://www.ga.gov.au/ausgeoid/nvalcomp.jsp>). The variation of the N values across Australia from Cape Leeuwin to Cape York are shown in Figure 2.5 - Figure 2.7. The model definitions are the AHD, Ausgeoid09/GDA94 separation scale is 1:1,250, and the terrain profile, i.e., the AHD/GDA94 separation is scale 1:12,500.

Height transfer between the GDA94 Ellipsoid and the Australian Height Datum is performed as follows:

1. AHD (roughly height above mean sea level on the local geoid) is transferred from Bench Marks using differential levelling or trigonometric height differencing.
2. GNSS (GPS) height surveying is referenced the GDA94 ellipsoid. This is very similar to the WGS84 ellipsoid used by GNSS satellites (see Chap 10 for more discussion).
3. GDA94 ellipsoid heights are transferred to the AHD using the AUSgeoid09 grid ellipsoid interpolation of the AHD – ellipsoid separation value, N .
4. N is realised to about 0.03m (1 sigma) over Australia, compatible with $k = 12\sqrt{d}$ (3rd order) levelling.
5. GNSS RTK surveys over a local area can have the observed ellipsoidal heights transferred to AHD using a single N value for the area.

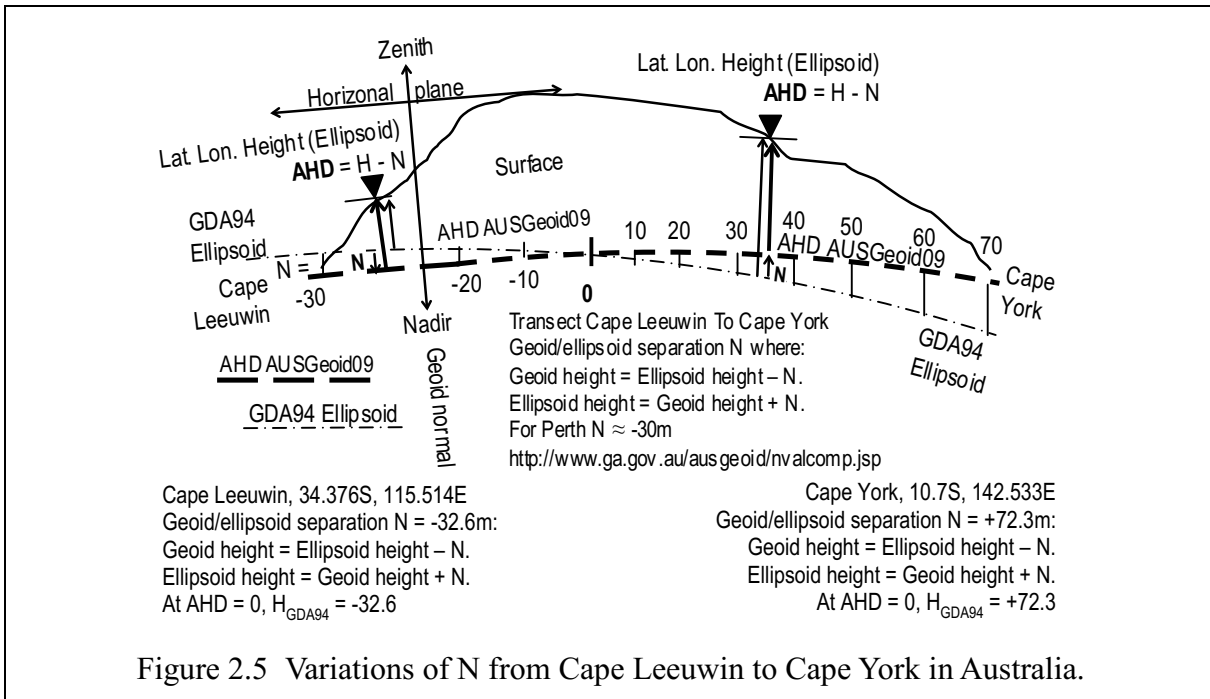
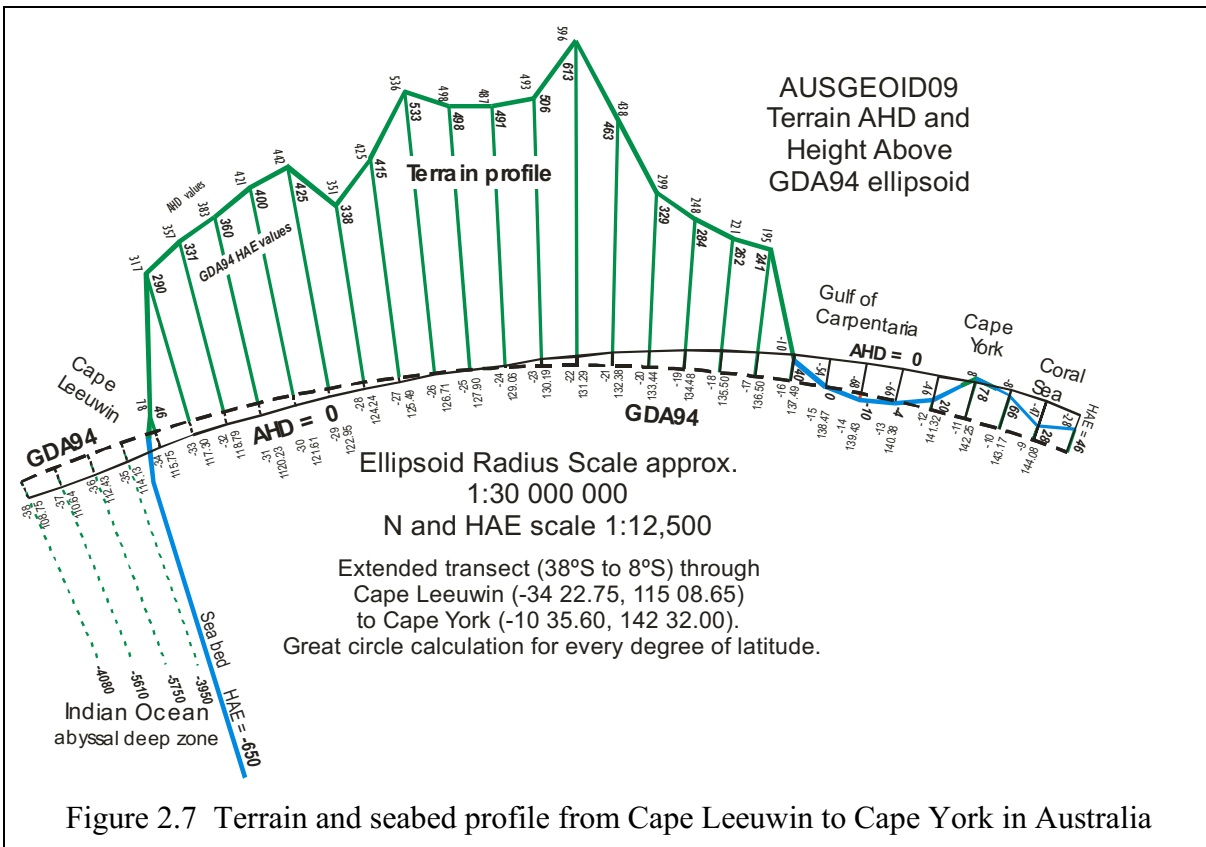
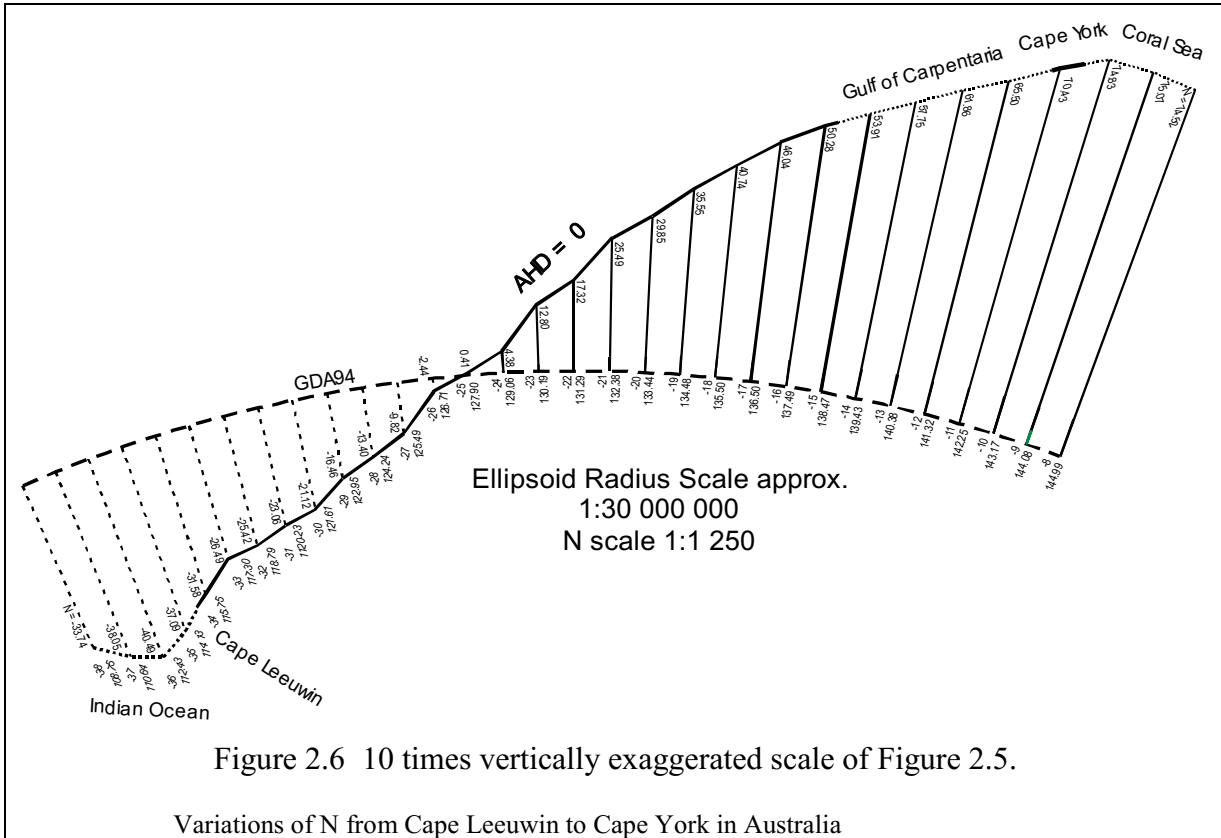
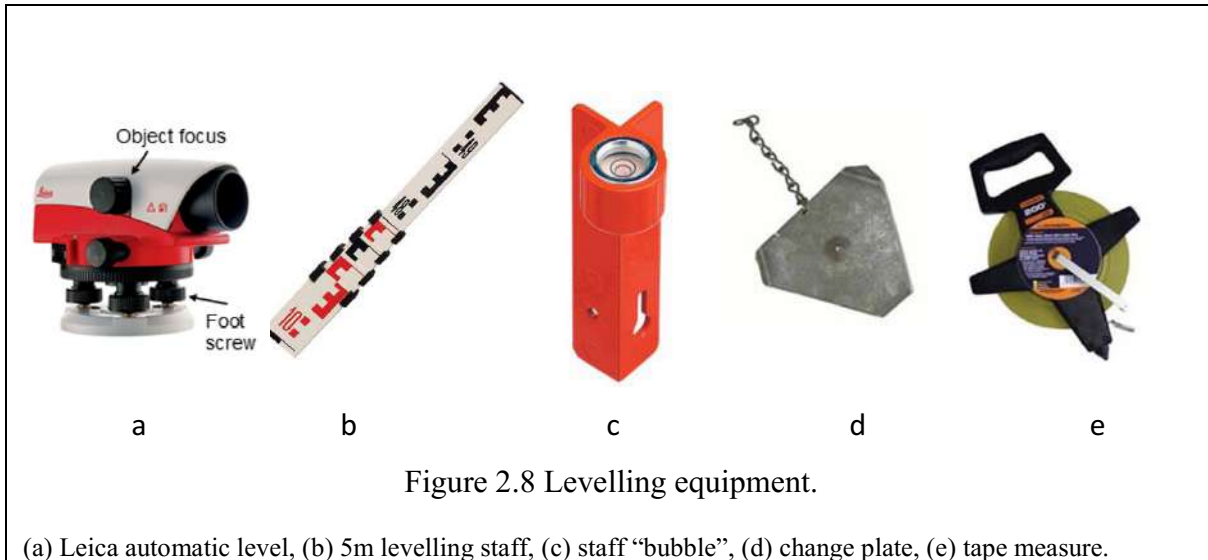

Figure 2.5 Variations of N from Cape Leeuwin to Cape York in Australia.



2.4 Instrumentation: Automatic Level and Staff

The instruments one needs to carry out levelling procedure discussed in Section 2.5 are a level and staff (Figure 1.5). In addition, one may need to have a measuring tape and a change plate (a metallic/plastic plate used on soft ground), see Figure 2.8. The staff “bubble” ensures the staff is held vertically. Before being used, the instrument has to be setup and levelled as discussed below. Refer to the Leica Geosystems NA724 User Manual, Version 1.0, English. Document NA720/724/NA728/NA739-1.0.1en which is generally provided in the instrument case.



2.4.1 Setting the instrument for area levelling

Leica manual, page 11. “Setting up the tripod”.

For differential levelling with an automatic level (Section 2.5.2), it is only necessary to roughly centre the circular level bubble on the instrument plate. The automatic compensator (pendulum) will provide the final levelling.

2.4.2 Levelling the instrument

Leica manual, page 12. “Levelling up”.

Mount the level on the tripod head using the centre bolt (e.g., Figure 1.5)

1. Centre the three foot-screws on the base plate (there is a mid-point mark on screw housing), see Figure 2.9.
2. Centre the circular level using the foot screws,
 - turn the level until its axis is parallel to two foot screws
 - simultaneously turn the two parallel foot screws in opposite direction
 - move the bubble towards the centre following your LEFT thumb,
 - then turn the level through 90°, perpendicular to the first axis foot screws,
 - using ONLY the remaining foot screw
 - move the bubble towards the centre following your LEFT thumb
 - you may need to repeat the procedure to centre the bubble correctly.

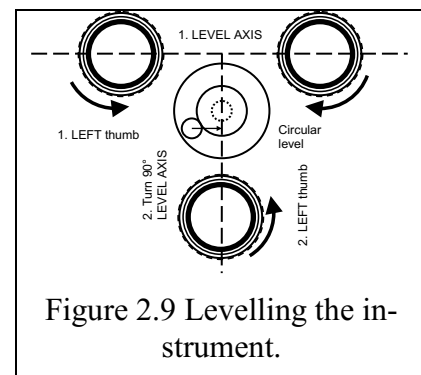

2.4.3 Focusing the instrument

Leica manual, page 13. “Focusing telescope”.

Correct focus of the eyepiece reticule and the object focus is critical to accurate observations. The following points apply to all optical observations.

The eyepiece focus is set once for EACH individual observer.

But the object focus (see Figure 2.8a. Figure 2.10), using the focussing knob on the side of the telescope, must be done for EACH observation.

2.4.3.1 Eyepiece focus

1. Place a light-coloured card in front of the OBJECT lens
2. Looking through the eyepiece, turn the EYEPIECE (diopetre) focus ring until the reticule engravings are sharp and dark (Figure 2.11).

2.4.3.2 Object focus

1. Point to the level staff, the point to be focused.
2. Looking through the eyepiece, turn the OBJECT focusing knob (Figure 2.12) until the image is in sharp focus on the reticule (Figure 2.13).
3. Observing the object, move your head up and down slightly to confirm there is no parallax in the focus between the line of sight of the reticule and the object.

2.4.3.3 Backsights and Foresights

“Sight” is the word meaning either an observation or a reading.

A **Backsight (BS)** is the **first** sight (reading) taken after setting the instrument in position for a reading. It is the beginning sight.

A **Foresight (FS)** is the **last** sight (reading) taken before moving the instrument to a new position. It is the ending sight.

An **Intermediate sight (IS)** is any sight taken between the BS and FS.

A **Change point (CP)** is the common position between two instrument setups. A CP has a **FS** from the previous instrument position and a **BS** from the next instrument position.

2.4.4 Reading the staff interval

Leica manual, page 15. “Height reading”.

The face of the staff is marked with an E pattern of 1cm graduations (see Figure 2.15). The observer is expected to interpolate the millimetre readings. Because of the eye’s ability to discriminate proportions, it is relatively easy to interpolate to the millimetre.

The levelling staff should be extended only to the amount needed for the exercise. Ensure the correct section segments are extended. Each segment is about 1m long.

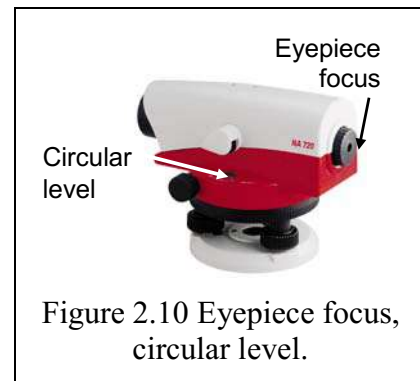

Figure 2.10 Eyepiece focus, circular level.

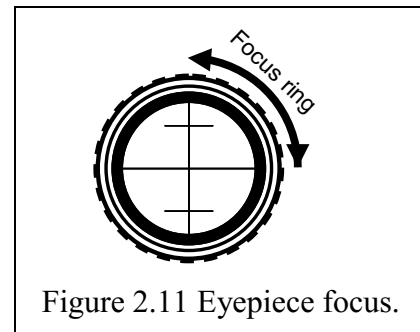

Figure 2.11 Eyepiece focus.

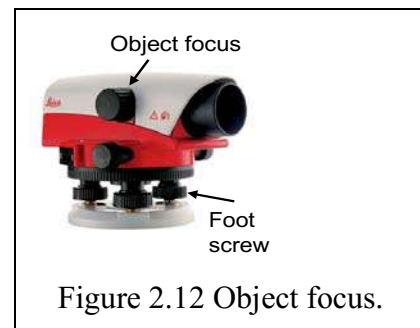

Figure 2.12 Object focus.

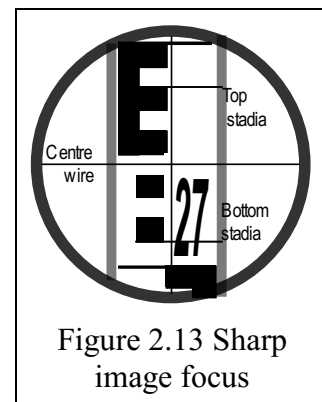

Figure 2.13 Sharp image focus

Object focus:

1. Focus on the staff with the OBJECT focus knob; the depth of field is shallow and requires critical focusing
2. Check for parallax in reticule.
3. Gently tap the side of the level to ensure freedom of the automatic pendulum compensator.

2.4.4.1 Staff reading

1. Using the **centre** cross hair, read the staff, estimating millimetres.
The illustrated staff on reads 2.745, the decimal point is inferred in the 27
2. Record the reading in **metres**.
3. Note that the two stadia wire, used for measuring distance, can be used as a check of the centre wire reading,
Top wire (TW) = 2.780

$$\text{Mean} = 2.745 = \text{centre wire}$$

$$\text{Bottom wire (BW)} = 2.710$$

$$\text{Distance} = (\text{TW} - \text{BW}) \times 100 \text{ (stadia constant)} = 0.07 \times 100 = 7\text{m}$$

Recording top and bottom wires can be a useful method of blunder detection.

The observer and the booker must work together to ensure that the readings have been recorded correctly. The booker should be able to reduce the readings, calculating RL from either rise/fall (Section 2.5.5) or height of collimation method (Section 2.5.7), and check for consistency. Furthermore, the booker should ensure an adequate description of the observed point. The final reduced level (RL) and all checks can be concluded quickly, before leaving the job. There is nothing worse than having to return to the job to fix a blunder.

2.4.4.2 Staff handling

1. Make sure the required staff sections are fully extended and locked.
2. When transferring heights, ensure that the base of the staff is on a stable point; a peg, a recoverable point or a firmly embedded change plate (Figure 2.8).
3. Minimum reading on the staff occurs when it is held vertical. This is achieved by using the “staff bubble”, a circular level held on the side of the staff. Slightly rocking the staff backwards and forwards to find the minimum reading is another method that could be used in the absence of a bubble.

2.4.5 Collimation checks (Two peg test)

Leica manual, page 21. “Checking and adjusting line-of-sight”.

To check that the instrument’s line of sight is horizontal it is necessary to perform a line-of-sight test. This is commonly called the “two peg test”. It should be performed on any instrument that is to be used in production prior to any project. The object of the test is to ensure that the line of collimation of the level is within manufacturer’s recommendations. Outside this limit the instrument should be re-tested and if still deficient, adjusted or sent for rectification.

The principle of the test is to find the difference in height between two points:

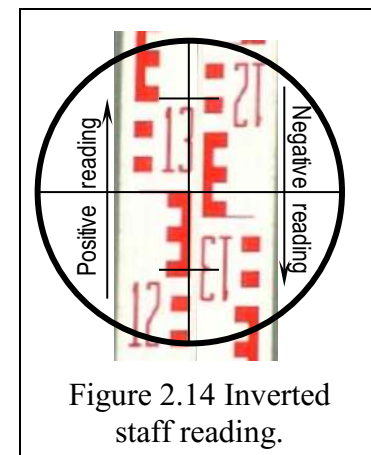
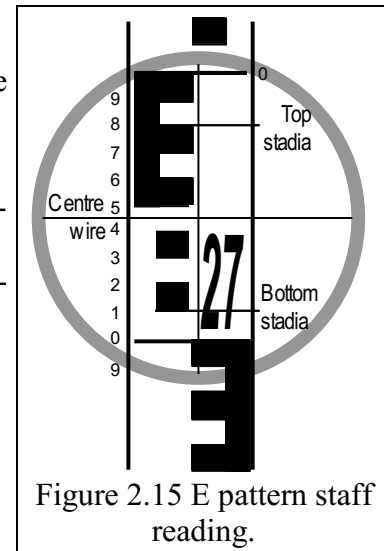

1. Eliminating collimation error by observing, Δh , from the mid-point (Figure 2.16)
 - line of sight (LoS) errors are cancelled (deflections, δ , cancelled).

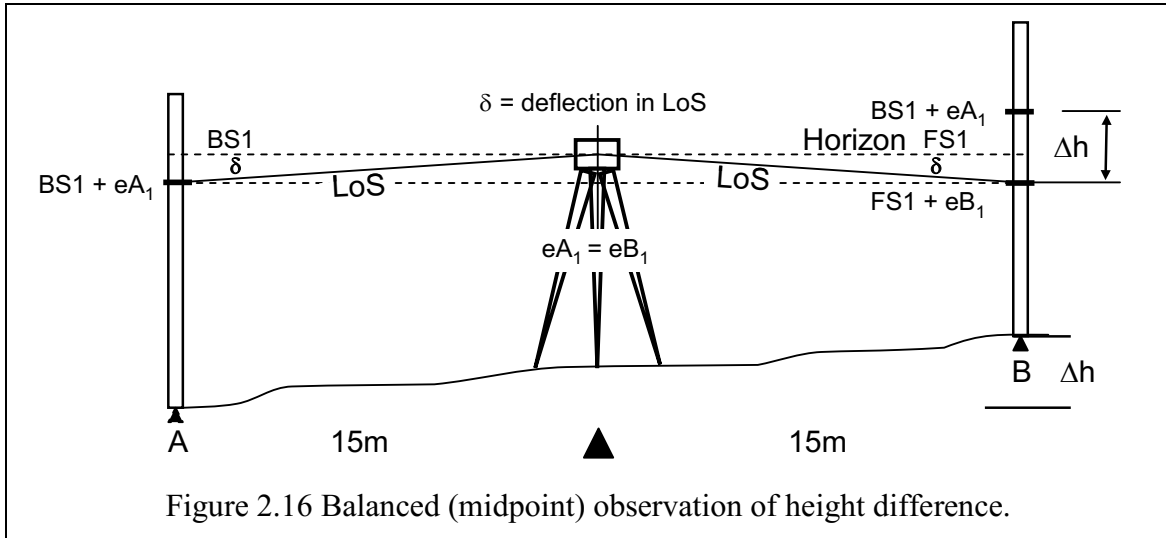

2. From a point close to A, 1 – 2m (Figure 2.17), determine $\Delta h'$ by observing over the full (30m) line-of-sight. The error in the line-of-sight is the discrepancy between the two observed height differences;
 - $|\text{error}| = |\Delta h'| - |\Delta h|$ (unbalanced deflection, δ).

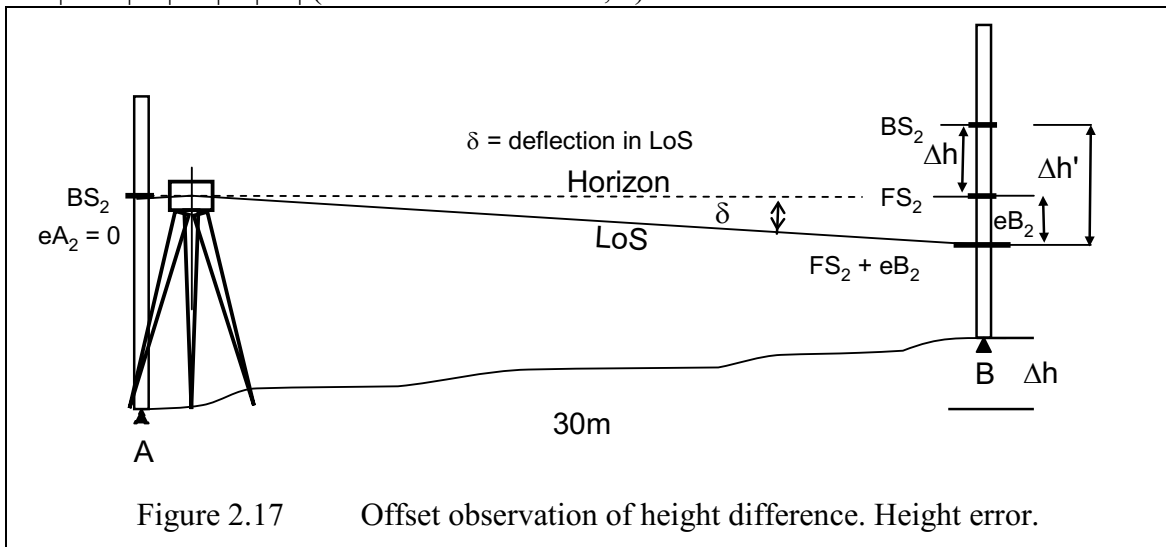

3. The recommended maximum error for the Leica Level NA720/724 is 3mm (0.003m) or 0.01ft. Imperial, or foot, staffs are marked in 1/100 of a foot.
4. Example of record sheet using the rise and fall booking method:

BS	IS	FS	Rise	Fall	Remarks
1.742					A_1 . Mid point. Equal error
		1.622	0.120		B_1 . Mid point. Equal error
1.580					A_2 . At staff. Zero error
		1.456	0.124		B_2 . 30m to B. All error
$\Delta h = 0.120$		$\Delta h' + eB_2 = 0.124$		$ \text{Error} = 0.124 - 0.120 = 0.004$	

Figure 2.18 Booking and analysis of a collimation test.

5. Figure 2.18 shows an error of 4 mm, outside manufacturer's specifications. The test would be repeated to confirm the result before any decision on adjustment is made. Or extra care could be used to balance foresight/back-sight observations.
6. If this measurement was confirming that the reticule needed adjusting, then the reading to B_2 would have to be adjusted so that the staff reading was:
 - $1.580 - 0.120 = 1.460$.

2.5 Measuring and Reduction Techniques

2.5.1 Basic Rules of Levelling

In using an automatic level for vertical control and height differences, you need to remember the following **six** rules of levelling:

1. The instrument must be properly levelled, pendulum free; check circular bubble, pendulum "tap".
2. Backsight distance should be approximately equal to the foresight distance. Stadia wires can be used to approximate the distances (see staff reading above).
3. Instrument, staff and change plate must be stable, and the staff kept on the change plate.
4. Staff must be vertical. Check that the staff bubble is centred.
5. Remove parallax, **read the centre wire**; sharp, coincident focus of reticule and object. Reticule (cross wire) focus set with eyepiece (diopetre) ring; object focus to eliminate parallax.
6. Close the traverse.

For all exercises in Appendix (A2-1), we assume that the Earth is FLAT. All calculations are based on plane trigonometry, and the horizontal plane is perpendicular to the local **geoid** normal. Distance measurements are generally less than 100 m and level observations are rarely over a distance of 50 m, generally 30 m is sufficient. These limitations then allow us to ignore the effects of Earth's curvature and scale factor. Heights will be referenced to the Australian Height Datum (AHD). The AHD was defined as mean sea level at 30 tide gauges around Australia, observed between 1966 and 1968 (Figure 2.3).

2.5.2 Levelling Specifications in Australia

The Intergovernmental Committee on Surveying and Mapping (ICSM) through its Special Publication 1 (SP1), Version 2.0 (2013) provides guidelines for Differential Levelling to achieve various levels of misclose.

Allowable misclose: When conducting differential levelling or Total Station differential levelling, errors propagate in proportion to the square root of the travelled distance. A misclose assessment should be undertaken to verify that forward and backward runs of a levelling traverse, including any individual bays, are within the maximum allowable misclose. The allowable misclose is calculated using the formula:

$$r_{mm} = n\sqrt{k} \text{ (k in km).}$$

Three standards, using empirical values, are recommended:

$$n = 2\text{mm}\sqrt{k}, n = 6\text{mm}\sqrt{k} \text{ and } n = 12\text{mm}\sqrt{k}.$$

Equipment: For the recommended maximum allowable misclose of $12\sqrt{k}$ (forward and back). A 2 mm/km optical level; collimation check at start of project; wood or fibreglass staff, calibrated within 5 years; staff bubble attached and accurate to 10' verticality, telescopic tripod; standard change plate; thermometer accurate to 1°C.

Observation techniques: Two-way levelling; foresight approx. equal to backsight; staff readings to 1 mm; temperature recorded at start and at 1 hour intervals, or at pronounced changes to conditions; maximum sight length 80 m; minimum ground clearance 0.3 m. One of

the automatic level used for the levelling exercises is the Leica NA720/NA724, a general-purpose surveying and construction level. Accuracy is quoted as 2.5 mm/km for the NA720, not meeting SP1 specifications.

Refer to the “Leica NA720/724/728/730 Instruction Manual, English, Version 1.0” by Leica Geosystems. This manual is contained in most instrument cases.

2.5.3 Differential Levelling: The “Rise and Fall” method

Levelling procedure:

- ✓ A horizontal line of sight is established using some form of levelling mechanism:
 - Spirit level tube
 - Swinging pendulum
- ✓ A graduated staff is read through the telescope of the level
- ✓ The elevation of points can be established by first reading the staff on a Bench Mark (BM)
- ✓ The staff is then moved to the desired point, the level is turned and the staff is read again
- ✓ The reading at the benchmark (BM) is called the backsight (BS), see BS1 in Figure 2.19.
- ✓ The reading taken after turning the instrument and moving the staff is the foresight (FS), see FS1 in Figure 2.19.
- ✓ To continue levelling, the staff is kept on the point at B and the instrument moved to the midpoint between B and the next point, C, i.e., STN 2.
- ✓ B is called the change point (CP) or turning point (TP)
- ✓ The staff at B is carefully turned toward the instrument and a BS reading taken
- ✓ Then the staff is moved to C and a FS reading is made
- ✓ The procedure is repeated as many times as needed
- ✓ The levelling should always end on a BM (i.e., D) as a check!

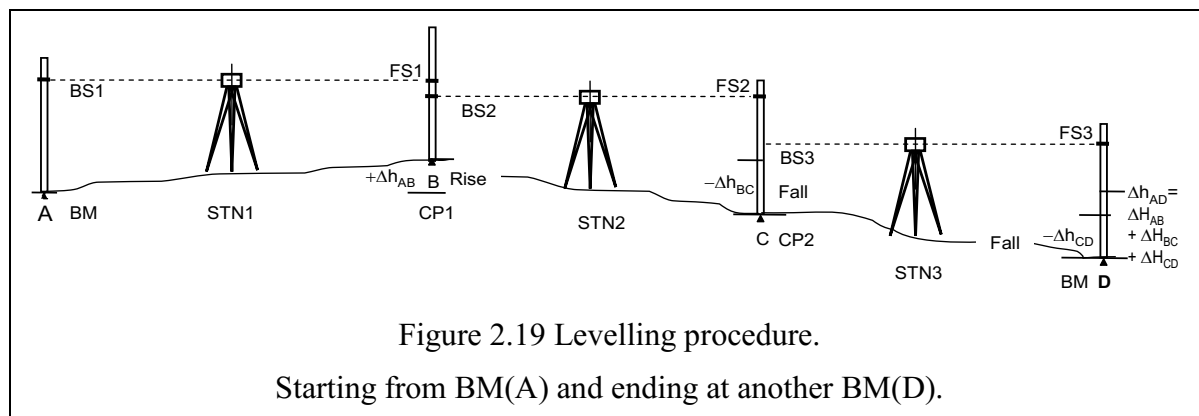

2.5.4 Booking and field reduction procedures for levelling

Two note reduction methods for calculating elevations from the BS and FS observations exist. Each of the methods uses only two equations for the computations. These methods are

- Rise and Fall method (i.e., a fall is simply a negative Rise);

$$\text{Rise (or Fall)} = \text{BS} - \text{FS}$$

$$\text{Elev} = \text{Previous elev} + \text{Rise (or Fall)}$$

- Height of Collimation method;

$$HI = Elev + BS$$

$$Elev = HI - BS$$

In what follows, a detailed examination of the methods is presented.

2.5.5 Rise and Fall Booking and Reduction Procedures

The “rise and fall” method of booking allows three sets of checks to be applied to the booked values. It only checks the calculations, not the booked observed values. Transfer a control point level (bench mark) at A to a new control points at B and C, checked by closing to control point at D. Referring to Table 2-1, the field book recording and checking by “rise and fall” observations are:

Control point A has a known RL of 10.125

Control point D has a known RL of 8.930

difference $\Delta h_{AC} = 8.930 - 10.125 = -1.195$

Table 2-1 Rise and fall, checking calculations.

BS	IS	FS	Rise	Fall	RL	Remarks
1.742					10.125	A. Control point.
1.580		1.522	0.220		10.345	B. Change point 1
0.625		1.892		0.312	10.033	C. Change point 2
		1.732		1.107	8.926	D. Observed R.L.
Sum		Sum	Sum	Sum		
3.947		5.146	0.220	1.419		
$\Sigma BS - \Sigma FS$		$\Sigma Rise - \Sigma Fall$		Last RL - First RL		
	-1.199		Diff =	-1.199	-1.199	$\delta h'_{AD}$ Last - First
Three checks agree. The math checks agree with the booked observations.						

However, Table 2-2 shows there is a discrepancy (misclose) between the booked observations and reductions and the known RLs of A and D of 0.004. This may need to be investigated, or accepted (with justification in relation to job specifications).

Table 2-2 Establishment of misclose.

					10.125	A. BM (fixed)
					8.930	D. BM (fixed)
					-1.195	δh_{AD} Last - First
			Misclose		+0.004	$\delta h_{AD} - \delta h'_{AD}$

Three wire booking: using the stadia wires

Leica manual, page 16. “Line levelling”.

At each level reading, the three wires, the horizontal centre wire and the two stadia wires, may be booked so as to provide, a) a check against blunder readings and b) a calculation of distance to the staff. (Stadia constant 100).

Table 2-3 Three wire readings.

BS	IS	FS	Rise	Fall	RL	Remarks
1.542						Top wire
1.742					10.125	A. Control point.
1.943						Bottom wire
1.653		1.627				Top wire
1.590		1.522	0.220		10.345	B. Change point 1
1.407		1.417				Bottom wire

The above snippet of field book, Table 2-3, shows:

BS to A. The middle wire (MW) is in agreement with the top wire (TW) and the bottom wire (BW). Distance = $(1.943 - 1.542) \times 100 = 40.1 \text{ m}$

FS to CP1. MW agreement. $(TW+BW)/2 = MW$. Distance = $(1.627 - 1.417) \times 100 = 21 \text{ m}$
 After **changing** observation station, reading: **BS to CP1.** MW disagrees with $(TW+BW)/2 = 1.580$. Is it a booking blunder?

- **Check.** Distance 24.6 m. Further checking: $(TW - MW) \times 200 = 12.6 \text{ m}$,
 $(MW - BW) \times 200 = 36.6$.

- **Solution.** Re-observe BS to check before the next FS reading.

Do not take the “mean” value between TW and BW to get a “refined” MW reading. Use it as a **check**.

Could you “assume” a misreading of the mid-wire, correct the reading to 1.580 and then use this as the “correct” BS reading to the next fore station?

2.5.6 Area Levelling: The “Rise and Fall” Method

The “rise and fall” method of booking will be used instead of the illustrated “height of collimation” method in Section 2.5.7. Again, we are only checking the calculations, not the booked observed values. In the two levelling exercises in Appendix A2-1, there will normally be a mix of “line” and “area” levelling observations. All observations, other than the back sight (BS) and the fore sight (FS) are considered intermediate sights (IS) and are booked in the IS column of the “rise and fall” booking sheet.

Exercise 1 is the transfer of reduced levels (RL) to temporary control points (temporary bench marks, TBM) from existing BMs. You may have to use intermediate sights (IS) to establish these TBM, and will have to use them to answer some of the exercise questions.

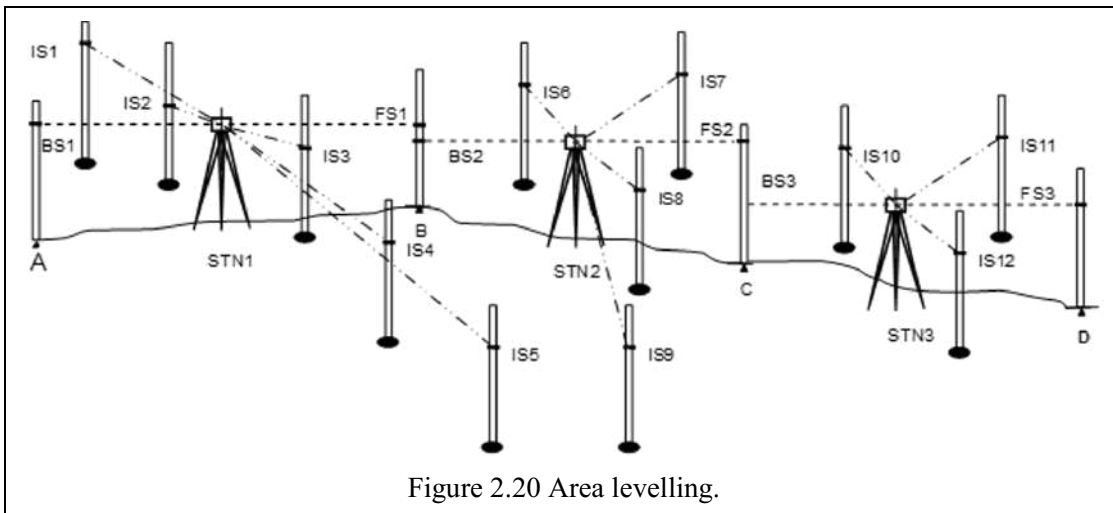

Figure 2.20 Area levelling.

Exercise 2, the area levelling and mapping exercise, will use mainly IS to pick up cross section levels, but will also require a number of change points (CP) to carry observations through the area.

Table 2-4 is an example of booking intermediate sights (IS) between back sights and fore sights, and checking the reductions for observations taken in area, Figure 2.20.

BS	IS	FS	Rise	Fall	RL	Remarks
1.742					10.125	A. Control point.
	1.628		0.114		10.293	IS1
	1.205		0.423		10.662	IS2
	1.585			0.380	10.282	IS3
	1.625			0.040	10.242	IS4
	1.550		0.075		10.317	IS5
1.580		1.522	0.028		10.345	B. Change point 1
	1.635			0.055	10.290	IS6
	1.640			0.005	10.285	IS7
	1.825			0.185	10.100	IS8
	1.745		0.080		10.180	IS9
0.625		1.892		0.147	10.033	C. Change point 2.
	1.254			0.629	9.404	IS10
	1.365			0.111	9.293	IS11
	1.158		0.207		9.500	IS12
		1.732		0.574	8.926	D. Observed R.L.
Sum		Sum	Sum	Sum	8.930	D. BM RL 8.930
3.947		5.146	0.927	2.126		closed to 0.004m
$\Sigma BS - \Sigma FS$			$\Sigma Rise - \Sigma Fall$		Last RL - First RL	
	-1.199		Diff =	-1.199	-1.199	$\delta h'_{AD}$ Last - First
Three checks agree. The maths agrees with the booked observations.						

Note that while the checks agree with each other, no maths problems, there is still a discrepancy between the calculated RL of BM D and its true value. This is likely a random error misclose

The check sums only validate the mathematics of the reduced observed values. It does not mean that the individual observed values are correct. A blunder reading itself can't be isolated between check points.

2.5.7 Area Levelling: The "Height of Collimation" Method

This method, see Table 2-5, using the area in Figure 2.20, is easy to use both for level pick-up and for level set-out. A staff back sight (BS) to a known level (point or BM) is taken and added to the known RL. This becomes the "height of collimation" of the level. It is the RL of the observed horizontal plane, the instrument horizon, i.e.,

$$HC = \text{KnownRL} + BS$$

$$RL \text{ of any point} = HC - IS \text{ or } FS$$

The RL of any point = HC – IS/FS, the staff reading. This method allows change points (CP) to be introduced as temporary bench marks (TBM). The next instrument set-up has a new HC based on the RL of the CP and the new FS.

The method is used for setting-out of vertical control and is the basis of setting-out using rotating laser levels and detectors. Once the HC has been established from a known RL, it is

Table 2-5 Height of collimation booking and reduction.

BS	IS	FS	HC	RL	Remarks
1.742			11.867	10.125	RL A. BM . HC for STN1.
	1.628			10.293	IS1
	1.205			10.662	IS2
	1.585			10.282	IS3
	1.625			10.242	IS4
	1.550			10.317	IS5
1.580		1.522	11.925	10.345	B. CP 1. HC. For STN2. RLB + FS
	1.635			10.290	IS6
	1.640			10.285	IS7
	1.825			10.100	IS8
	1.745			10.180	IS9
0.625		1.892	10.658	10.033	C. CP 2. HC. For STN3. RLC + FS
	1.254			9.404	IS10
	1.365			9.923	IS11
	1.158			9.950	IS12
		1.732		8.926	D. BM D. RL 8.930
Sum		Sum			closed to 0.004m
3.947		5.146			
$\Sigma BS - \Sigma FS = -1.199$				-1.199	$\delta h'_{AB}$ Last - First

merely a case of raising or lowering the staff until the required level coincides with the base of the staff. The established level is marked by be a peg driven to level, or a line on a stake.

From CP2 (Table 2-6), you wish to establish a design level of RL10.5 over an area. The instrument has been moved and the RL of BM B is used as a control. Additional levels, for other design RLs, are also illustrated. Store the HC in your calculator and use that value, minus the required level, to find the staff reading.

Table 2-6 Calculate IS to setout of design levels.

BS	IS	FS	HC	RL	Remarks
1.370				10.345	RL B.
			11.715		HC. For CP2. RLB + FS
	1.215			10.500	Finish level required.
Set IS	1.215				$11.715 - 10.5 = 1.215$
	1.315			10.400	Calculated IS. Design RL
	1.415			10.300	Design RL
	1.515			10.200	Design RL
	1.615			10.100	Design RL

There is no easy way to check the RL of intermediate levels compared with the “rise and fall” method.

Distribution of misclose? Not in this course.

If the traverse misclose is within allowable limits, then there is an argument for the distribution of a correction through the points. It is carried out in proportion to the number bays; above we have -0.004 over 3 bays (A – B, B – C, C – D). The correction is $+0.004/3$ per bay cumulative as, say, $+0.001$ A to B, $+0.002$ B to C, $+0.004$ C to D.

Uren and Price (2010), section 2.4, p49 gives details. However, it is hard to differentiate between random errors and systematic errors (collimation caused by unequal BS/FS). Thus, distribution of misclose is **not** used in this course. Miscloses must always be judged on tolerances and the aim of the task, and an engineering decision made.

2.6 Examples of Levelling for Height Control

Two exercises were designed for the Curtin University Civil and Mine engineering courses. The exercises illustrate the use of appropriate practical exercises in available area:

Establishment and transfer of levels using **differential** levelling is used to find the level of new and established control points. The method transfers the **orthometric** height throughout a level network. Control levelling must always close back to a known point or to, at least, a previously established intermediate point in the network. Students use this differential method in Field Practical 1 to set level control for their area levelling exercise in Field Practical 2 (see Appendix A2-1).

2.6.1 Civil Engineering for a Road Excavation Exercise

The exercise (Figure 2.21) area is about 100m x 50m on a sloping site, falling to the south east over a height difference of some 3.5m. The area features pine trees, paths and service boxes. These features lend themselves to various forms of mapping which are explored through the course.

- a. Exercise 1 involves a level collimation test, then establishment of vertical control to be used in exercise 2. It is an opportunity for students to become familiar with instrument setup, focussing and staff reading and recording.

The level collimation exercise provides a practical example of balanced back sight/fore sight observation carried out by each student as an independently (moving and re-setting the level). Booking and field reduction, and evaluation of results, is practiced. The exercise includes an introduction to site reconnaissance, location of control points and establishment of task objectives.

- b. Exercise 1 then examines level runs of two type for control establishments:

- an open traverse from an established bench mark, via an inversion observation to check portal clearance.

It introduces change points for the rise and fall method of booking.

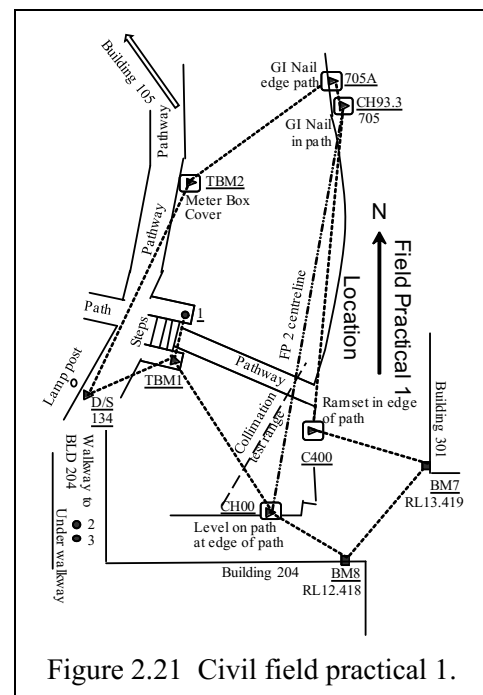
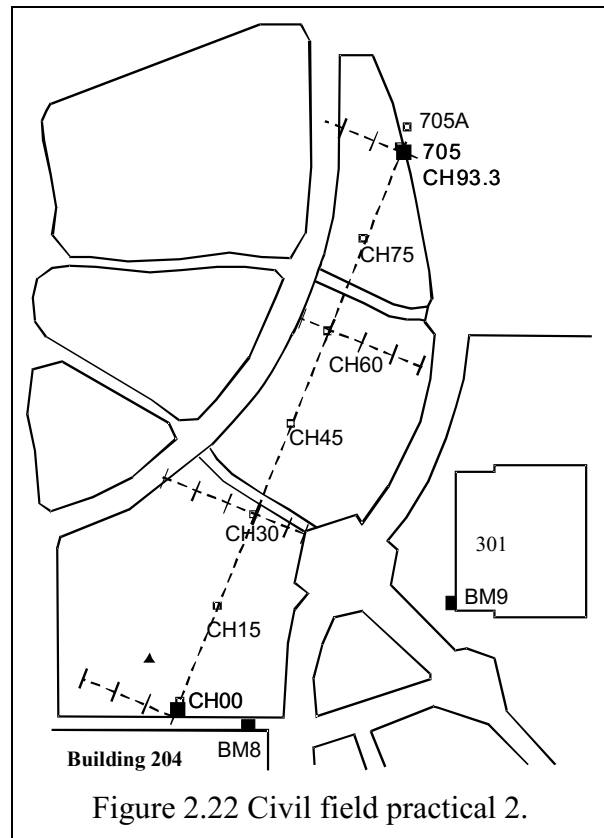

Figure 2.21 Civil field practical 1.

- a closed loop traverse, finishing at a different bench mark, traverses through some of the open loop marks. The exercise requires a number of change points to be used, giving team members the opportunity to carry out observation, booking and staff handling tasks. The exercise timing allows field checking of results before task completion.
- c. Exercise 2 (Figure 2.22) incorporates field set-out of a perpendicular offset grid along an established centre line. The task continues from control established in exercise 1 and introduces area levelling observation, booking and reduction. Multiple change points allow rotation of observation tasks.
- the chainage and offset method of field mapping is used to locate trees, services and feature boundaries. From this field data, a scaled plan of the exercise area is produced showing feature and the boundaries of a design excavation along the centre line.
 - field data is used to calculate the volume of a cutting of designated slope and batter intercepts.



2.6.2 Mining Engineering Surveying for a Site Development

The exercise area is about 120 m x 90 m on a sloping site, falling to the south east over a height difference of some 6 m. The area features pine trees, paths and service boxes. These features lend themselves to various forms of mapping which are explored through the course.

- a. Exercise 1 (Figure 2.23) involves a level collimation test, then establishment of vertical control to be used in exercise 2. It is an opportunity for students to become familiar with instrument setup, focussing and staff reading and recording. The level collimation exercise provides a practical example of balanced back sight/fore sight observation carried out by each student independently (moving and re-setting the level). Booking and field reduction, and evaluation of results, is practiced.

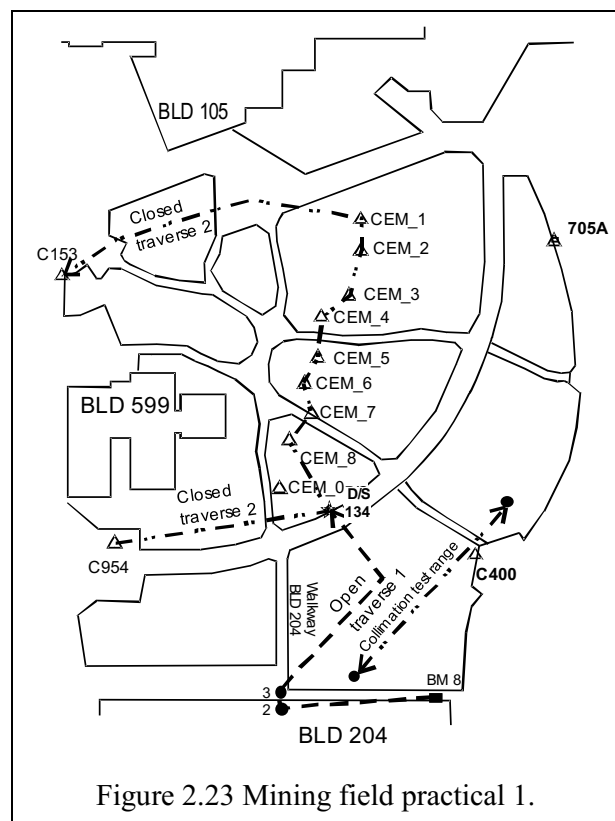

The exercise includes an introduction to site reconnaissance, location of control points and establishment of task objectives.

- b. Exercise 1 then examines level runs of two type for control establishments:

- an open traverse from an established bench mark, via an inversion observation to check portal clearance. It introduces change points for the rise and fall method of booking.
- a closed loop traverse, finishing at a different bench mark, traverses through some of the open loop marks. The exercise requires a number of change points to be used, giving team members the opportunity to carry out observation, booking and staff handling tasks. The exercise timing allows field checking of results before task completion.

- c. Exercise 2 (Figure 2.24) incorporates field set-out of a rectangular grid along over a designated area. The task continues from control established in exercise 1 and introduces area levelling observation, booking and reduction. Multiple change points allow rotation of observation tasks.

- grid layout of a typical blasting grid. Area levelling, using the Height of Collimation method illustrates field practice.
- grid method (estimating position in grid cell) of field mapping is used to locate trees, services and feature boundaries. From this field data, a scaled plan of the exercise area is produced showing feature and the boundaries of a design excavation area.
- field data is used to calculate the volume of an excavation down to a design level.

2.6.3 Grid Layout for levelling

The survey area should be gridded in a rectangular pattern aligned N-S and E-W, or as dictated by the main axis. This will allow easy integration to the local coordinate system for the GIS/CAD systems. A plan of the work area allows **determination** of the grid area, and its alignment. The base control points should be referenced to known control to allow incorporation of the grid coordinates into the local survey grid system. The alignment axis can be indicated by survey stakes, ranging poles or pathways. Ranging poles and cloth tape will be used to place chaining arrows at the grid intersections.

The height of collimation method of recording will allow quick reduction of the DEM levels.

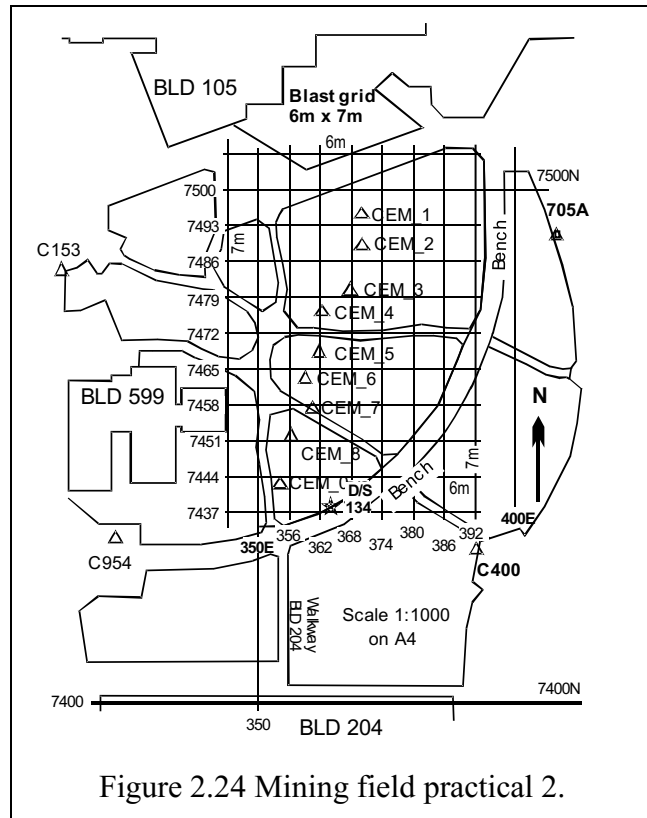

Figure 2.24 Mining field practical 2.

2.6.4 Orthogonal Grid Layout Methods

The requirement for a grid is that it should be orthogonal, i.e., the grid lines should be perpendicular to each other. How is this achieved?

3 – 4 – 5 triangle: The traditional technique is to use the dimensions of a plane right angle triangle as control. This method has been used since antiquity and continues today in the building industry. The best traditional triangle is the “3 – 4 – 5” triangle. 3 and 4 are the perpendicular axes and 5 is the length of the hypotenuse.

Establish the **grid origin** and lay out the extension of the main axis, marking it with stakes or ranging poles. Lay the tape on the ground from the origin. Place a survey pin at, say, 6.0m. From the origin lay a second tape at about right angles to the main axis. Measure down 8.0m. Check the diagonal from the 6m pin and adjust the 8m alignment until the diagonal distance reads 10.0m. Extend the alignment with a range pole and you have your main grid axes. It works with a 30m tape.

Optical square: It is a small hand instrument (Figure 2.25, Figure 2.26) used for laying off a right angle by means of two pentaprisms separated vertically by a small gap. The pentaprisms deflect the line of sight through the prism faces by 90° to the left and right.

If two range poles are coincident in the prisms, then a point also coincident through the gap is perpendicular to the line of the range poles (Figure 2.27). Hanging a plum bob from the prism allows a reasonable intersection.

Grid orientation: Grid orientation may be calculated by measuring in from known points to a convenient integer coordinate, or by examination of a site plan. Often plans will be plotted over existing features that can be used as a base line.

2.6.5 Height from Vertical Inclination

Part of the practical tasks involves finding the height of trees using a tape and **clinometer**. The enclosed case clinometer comprises a pendulous calibrated wheel supported on dual sapphire bearings in a fluid filled capsule. The face of the wheel is graduated 0° to $\pm 90^\circ$ and is read against an index on the capsule. The periphery of the wheel, viewed through the magnifying eyepiece, shows elevation and depression from the horizon. It is graduated in degrees (LHS) and percentage of horizontal distance (RHS) to the target. Typical performance is quoted as: accuracy $\frac{1}{4}^\circ$, graduation 0.5° .

The illustration shows the simultaneous view using both eyes, reading to the top of a tree trunk. The clinometer wheel is viewed with one eye, and the target with the other. (Tricky ‘til you get the hang of it.) The elevation reading is 7° (about 12%).

The height of the tree, above the observer’s eye, is the horizontal distance to target $\times \tan(\text{angle})$.

Assume H distance = 50m:

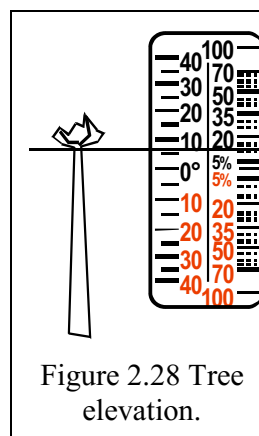

Figure 2.28 Tree elevation.



Figure 2.25 Optical square.

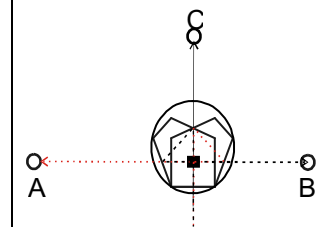

Figure 2.26 Optical path through square.

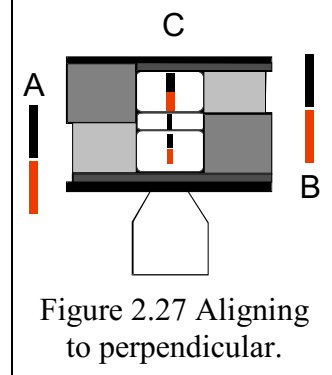
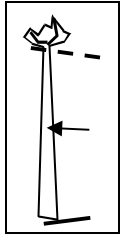

Figure 2.27 Aligning to perpendicular.

$$H_t = 50 \tan(7^\circ) = 6.1\text{m} \quad (50 \times 12\% = 6).$$

Take a second reading to the base of the tree, say -4° . $H_t = -3.5$.

$$\text{Tree height} = 6.1 - -3.5 = 9.6\text{m}.$$



Always measure from the longest possible distance away. The inclination angles are lower; the pointing errors associated large definition are minimised. Read to both base and top, you are thus independent of eye height, especially on sloping ground.

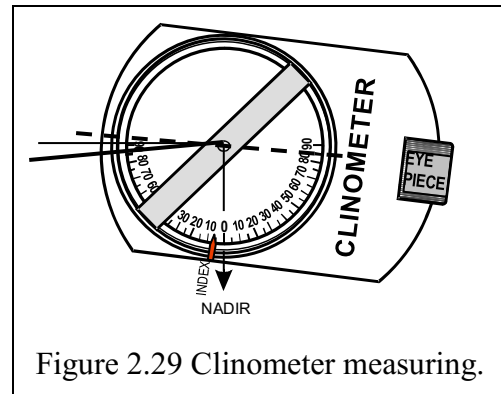

Figure 2.29 Clinometer measuring.

2.7 Errors in Levelling and Management Strategies

The best analytical discussion of errors in levelling is contained in Ghilani (chapter 9, pp151, *Error propagation in elevation determination*). As with any set of measurement observations, differential levelling is subject to three types of errors (i) systematic errors, (ii) random errors and (iii) blunders or mistakes and errors in datum total transfer.

2.7.1 Systematic Errors in Level Observations

1. Collimation errors, minimised by one of the rules of levelling:

Back sight and foresight approximately equal:

- an unbalance observation will introduce either a positive or negative systematic error depending on:

a) collimation error,

The Leica manufacturer's max for example is 0.003 (3 mm) in 30 m = 0.0001 radians = 21" arc.

b) difference between length of total back sights and total fore sights, error = distance x collimation error (radians).

- max errors; 0.001m at 10m, 0.005 m at 50m.

In an extended line levelling exercise, the difference in the sum of the distances covered as back sights and foresight may contribute to a significant systematic error.

2. Earth curvature and refraction, h_{CR} , minimised by one of the rules of levelling:

Back sight and foresight approximately equal:

- the staff reading error, in metres, combining curvature and refraction, is:

$$- h_{CR} = CR \left(\frac{D}{1000} \right)^2, \text{ where } CR = 0.0675 \text{ for, } D, \text{ in metres.}$$

An unbalanced set of observations will introduce a positive systematic error, e_{CR} , that must be **subtracted** from the difference in elevation

$$- e_{CR} = \frac{CR}{1000^2} \left(\sum D_{BS}^2 - \sum D_{FS}^2 \right).$$

CR is quoted as 0.0675 by Ghilani (2010). It is close to an empirical value of $k=1/14$ (0.07) developed by Bomford's investigation of curvature and refraction of radio and light waves in EDM (e.g., Bomford, §3.5, (1.34), p52).

The effect is minimal, for example (Ghilani 2010, p147). Take transfer of levels on a sloping site, where BS/FS can vary in the ratio of 5:1. A 1:6 slope (9.5°), with a 5 m staff, has a BS = 8m and FS =21m. Over 150m traverse, say 5 x 30m bays.

- $\Sigma_{BS} = 105, \Sigma_{FS} = 40. dS^2 = (105^2 - 40^2) = 9,425; e_{CR} = 0.0675/10^6 \times 9425m$
- $e_{CR} = 0.00064m$, under 1mm.

3. Staff calibration and mechanical construction errors:

It is generally assumed that staff markings have been manufactured accurately. They can be checked against a certified measuring tape (\$100) or by a certified testing authority.

Telescopic segmented staffs can suffer from worn locking mechanisms, especially over the base and 1st segment which are the most commonly extended sections. Use a tape cross the segment join to find any wear, making sure the staff is vertical to load the lock. (Figure 2.30).

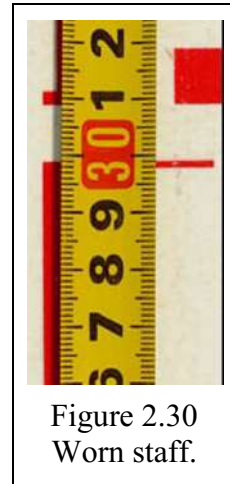

Figure 2.30 Worn staff.

- 4. If using two staffs, make sure they have similar base segment lengths, a worn staff foot could introduce a systematic error between staves, a staff datum error. Complete each pair of level bays by leapfrogging staves. Ensure an even number of bays.
- 5. Temperature expansion: staffs should be manufactured at a standard temperature, about 25°C,
 - a fibreglass staff has a temperature coefficient of about 10 ppm/°C
 - an aluminium staff has a temperature coefficient of about 25 ppm/°C

At 35°C, $\delta T = 10$, over a height difference of 50 m there would be an error of:

- 0.013 m using an aluminium staff $((50(dH) \times 25/10^6) \times 10 (\delta T) = 0.0125)$ and
- 0.005 m using a fibreglass staff.

2.7.2 Random Errors in Level Observations

1. Observer reading errors:

single reading error:

$$\pm 1.2 \text{ mm}/30 \text{ m} = 0.00004 \text{ radians} = 8'' \text{ arc}$$

2. Instrument level error: usually expressed as the:

- standard deviation in mm per km of double run levelling:
- $\pm 2 \text{ mm}/\text{km} = 2.0^{-6} \text{ radians} = 0.4'' \text{ arc}$

this value is in agreement with the declared compensator settling accuracy

3. Staff verticality, staff bubble error, δ

may be of the order of 5' arc, (Ghilani 2010, p149)

$$e_{LS} = \frac{h}{2} \sin^2 \delta, \text{ at } h = 5\text{m } e_{LS} = 0.005\text{mm}$$

- (1/200mm).

when $\delta = 1.5^\circ$, at $h = 5\text{m}$ then $e_{LS} \approx \pm 0.002\text{m}$

- **(2mm).**

The analysis (Figure 2.31) shows that a staff bubble should be used for all observations. But at normal observation levels, where $h = 2\text{m}$, a non-verticality of 2.5° is needed to produce a 2mm error.

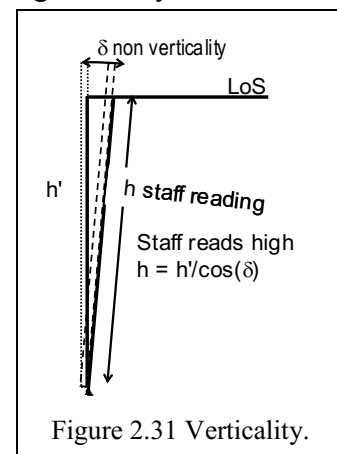

Figure 2.31 Verticality.

4. Lack of a staff bubble can be overcome by rocking the vertical staff slowly backwards and forwards, and reading the minimum height value on the mid wire. (Also, check verticality against vertical cross hair).

2.7.3 Observation Blunders and Mistakes

Likely sources of error in observations will come from:

1. Gross reading error of centre wire
 - read and record top and bottom stadia wires,
 - check mean.
2. Reading top or bottom stadia wire instead of centre wire.
3. Parallax in reading staff,
 - check reticule and object focus.
4. Unstable change points
5. Staff section not extended, or not locked (Figure 2.32).
6. Incorrect recording of Bench Mark data
7. Not using BM correctly
 - ensure correct reference surface (Figure 2.33).
8. Transcription errors in field book
 - poor character formation, printing, transposition.

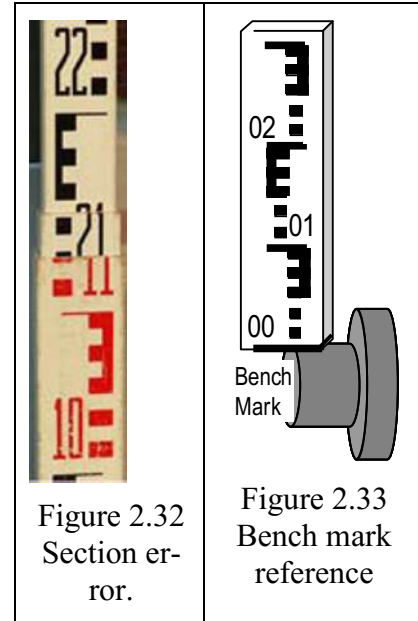

2.8 Concluding Remarks

This chapter has introduced you to levelling, i.e., the surveying procedure used to determine elevation differences. Arguably, most tasks that you will undertake in civil engineering and mining operations will require some sort of height (elevation) information. In the chapters ahead, we will see how this information becomes vital for the design/construction projects.

2.9 References to Chapter 2

1. Uren and Price (2010) Surveying for engineers. Fifth edition, Palgrave Macmillan, Chaps 2.
2. Ghilani, C (2010) Adjustment Computations Spatial Data Analysis. 5th ed., John Wiley, New Jersey 672 p.
3. Bomford, G (1980) Geodesy. Fourth edition, Clarendon Press, Oxford.
4. Featherstone, W., Kirby, J., Kearsley, A. et al. Journal of Geodesy (2001) 75: 313. doi:10.1007/s001900100177.
5. Leica Geosystems NA720/NA724/NA728/NA730 User Manual, Version 1.0, English.

Chapter 3 Relief and Vertical Sections

3.1 Introductory Remarks

In this chapter, we introduce you to the concept of relief and vertical sections and their applicability to civil and mine engineering. This chapter begins by providing definitions to terminology that will be used here and also in the workshop and field practical. We hope that by engaging the materials in this Chapter, the workshop and the field practical, you should:

- ✓ Be able to define relief and know the elements in representation of relief.
- ✓ Know the importance of relief in civil and mine engineering.
- ✓ Understand the nature of vertical sections (longitudinal and cross sections).
- ✓ Understands the characteristics of contours.
- ✓ Understand the surveying procedures for tracing contours in the field.
- ✓ Be able to interpolate contour lines from survey data.
- ✓ Be able to distinguish between DTM and DEM and know their uses.
- ✓ For the civil engineers, be in a position to design a foot/cyclic path from levelling data, i.e., RLs and FLs (e.g., field practical 2).
- ✓ For the mine engineers, be able to undertake the establishment of a gridded area to provide levels for the design of blasting operations in an open cast mine site.

Essential references include Schofield and Breach (2007) and Irvine and Maclellan (2006).

3.2 Definitions

1. **Relief:** A relief is a general term applied to the shape of ground in a vertical plane. The representation of a relief on a map is the showing of heights and shape of the ground above a datum, which is normally the mean sea level (MSL). Relief can be represented by heights, shapes, spot heights and contours. Representation of heights is largely a factual matter in which variation will arise from the type, density and accuracy of the information provided while the representation of shape is largely artistic and the methods vary on different maps. Maps designed for architectures and engineers for design purposes usually represent relief by either spot heights or contours or both.
 - In engineering, representation of relief is necessary in order to allow designs of constructions to be drawn in a manner that “harmonizes” with site.
 - When it is not possible for the engineer to visit the site, he/she may rely on a graphical representation of relief in form of a map.
 - All topographical maps have some representation of relief.
 - The extent of relief shown on a map will depend on the scale and purpose of the map.
2. **Scale:** A scale is the ratio of a distance on the ground to the same distance on a map, e.g., 1:20,000. 1 unit on the map represent 20,000 units on the ground.
 - 1 unit on the map is equivalent to 20,000 units on the ground.
 - 1 m on the map is equivalent to 20,000 m on the ground.
 - 1 mm on the map is equivalent to 200 m on the ground.
3. **Spot heights:** These are less accurate heights and normally without any definite mark on the ground.
 - They are selected to indicate the height of the ground at random points such as tops of hills and slopes, bottom of valleys, ridge points etc., to supplement information by contours.
 - They are shown by a dot with the height value.

- The accuracy will vary, but should be as accurate as the contours. Spot heights are written with decimal point on the point on the ground, and the height value is written on the slope so that it may be read from the bottom right corner of the map.
4. **Contours:** A contour is a line on the map joining points of equal heights, and is the standard method of showing relief on topographical maps. Contouring combines an accurate indication of height with good indication of shapes, especially when used in conjunction with spot heights. Heights for establishing contours can be obtained from angular measurements (known as trigonometric heighting, see Chap 6), levelling discussed in Chap 2, and from gridding as we shall see in Sect. 3.4.12.

Uses of contours:

- Used for constructing longitudinal and cross-section for initial investigations (see below for definitions of longitudinal and cross sections).
- Used for generating DEM and DTM (will be discussed in a later section).
- Used to construct route lines of constant gradient.
- For computing volumes (see Sect. 3.4).
- Delineate the limits of constructed dams, roads, railways, tunnels, etc.
- Delineate and measure drainage areas.

Properties of a contour:

- They are normally continuous lines (brown). Every fourth or fifth contour depending on the vertical interval is called index and is normally made thicker for easier reading.
 - Horizontal separation indicates the steepness of the ground.
 - Highly irregular contours define rugged terrain.
 - Concentric close contours represent hills or hollows.
 - Contour lines crossing a stream form V's pointing upstream.
 - The edge of a body of water forms a contour line.
 - Vertical distance between contours is called interval. The choice of this vertical interval depends on (i) the type of scale of the map and type of country mapped, e.g., on a 1:50,000 map with average relief, a contour interval may be 10 or 20 m while at 1:12, 000 scale it is probably 0.5 m, (ii) type of project involved, e.g., contouring an airstrip requires an extreme small interval, and type of terrain; flat or undulating. The interval can be used to calculate gradients through "Gradient = Vertical interval/horizontal equivalent". For the purpose of cost, the smaller the interval the more the cost.
5. **Longitudinal and cross sections** (Irvine and Maclellan 2006, Chapter 6):
- Longitudinal section – Vertical section along the centre line of the complete length of the work.
 - Cross sections – Vertical sections drawn at right angles to the centre line of the works.
- Information given by the sections provides data for:
- (a) Determining suitable gradients for construction work.
 - (b) Calculating volumes of earthworks.
 - (c) Supplying details of depth of cutting or heights of filling required.
- Example: Levelling is undertaken at the centre line and cross sections. See Table 3-1.
6. **Formation and Inverted Levels** (Irvine and Maclellan 2006, Chapter 6):
- *Formation level* of any construction works is the level to which the earth is excavated or deposited to accommodate works (e.g., the straight line rising from CH00 with RL of 12m to CH93.3 with RL of 14.25m in Figure 3.1). Formation width is the width of the design feature, e.g., a road.

- *Inverted level* is the inside of the bottom of a pipe but for practical purposes maybe considered to be the bottom of excavation.

Table 3-1 Reduced levels for a road design.

BATTER INTERCEPTS FROM CROSS SECTION LEVELLING

RL	RMK	Above DATUM RL 12.00	$m = 4$	$h_L = (W_L - b/2)/m$	W_L	Slope k @ 5m or offset interval	CL Grade Final Level	$h_v =$	Slope k @ 5m or offset interval	W_R	$h_R = (W_R - b/2)/m$
			$b = 5$					CUT/Fill			
13.191	00 15L	1.191	15L			15.9		1.19			
12.876	00 10L	0.876	10L			8.4		0.88			
12.281	00 5L	0.281	5L	0.18	3.2	17.8		0.28			
12.00	CH 00 CL	0.000	0				0.00	0.00			
12.00	00 5R	0.000	5R					0.00	∞ or level	2.5	0
12.80	CH 15 CL	0.800	15				0.36	0.44			
14.585	30 15L	2.585	15L			11.1		1.86			
14.132	30 10L	2.132	10L			13.0		1.41			
13.747	30 5L	1.747	5L	1.20	7.3	14.4		1.02			
13.40	CH 30 CL	1.400	30				0.72	0.68			
12.96	30 5R	0.960	5R					0.24	-11.4	3.9	0.35
12.725	30 7R	0.725	7R					0.00	-8.5		
13.90	CH 45 CL	1.900	45				1.09	0.81			
14.614	60 6L	2.614	6L			33.3		1.17			
14.584	60 5L	2.584	5L	1.20	7.3	17.6		1.14			
14.30	CH 60 CL	2.300	60				1.45	0.85			
14.129	60 5R	2.129	5R					0.68	-29.2	5.2	0.68
13.884	60 10R	1.884	10R					0.50	-20.4		
13.711	60 15R	1.711	15R					0.32	-28.9		
14.50	CH 75 CL	2.500	75				1.81	0.69			
15.177	90 9.5L	3.117	9.5L			14.1		1.05			
14.858	90 5L	2.585	5L	0.73	5.4	9.0		0.73			
14.30	CH 90 CL	2.300	90				2.17	0.13			
14.153	90 1.8R	2.153	1.8R					-0.02	-12.2	2.5	0
14.25	CH 93.3	2.250	93.3				2.25	0.00			
Grade Slope = 1:41.5		Grade slope = run/rise = 93.3/2.25 = 41.5									

The plotted longitudinal profile of reduced data in Table 3-1 is shown in Figure 3.1

7. Embankment and Cutting

- Embankment – The formation level of the proposed works is higher than the actual ground level such that the side slope (batters) slope downwards from the formation level to the ground (see e.g., Figure 3.2).
- Cutting is the opposite, i.e., when the formation level is lower than the actual ground (see e.g., Figure 3.3).

8. Design gradient, batter gradient, and surface gradient

Design gradient is the slope of the design feature, e.g., a road (rising or falling as discussed in Chapter 9). Batter gradients are the side slopes in Table 3-1 Reduced levels for a road design. above, while surface slope (k) is the slope of the actual ground surface (see Section 3.4).

- Chainage** – This is the linear measurement from the start of the structure, e.g., road along the centreline at given intervals. They are normally specified at the design stage and useful in specifying points at which reduced levels should be taken for the generation of longitudinal and cross-sectional profiles.

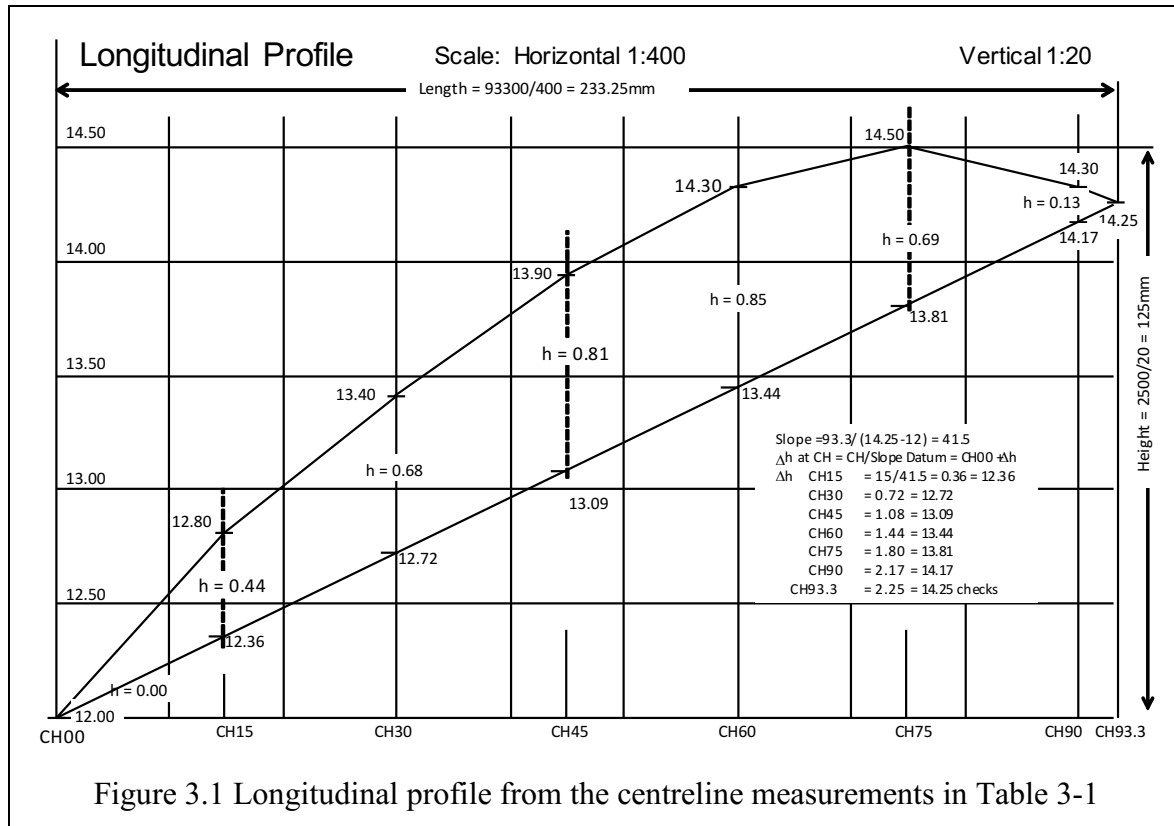

Figure 3.1 Longitudinal profile from the centreline measurements in Table 3-1

10. Digital Elevation and Digital Terrain Models

- DEM (Digital Elevation Model) is the representation of terrain surface numerically by very dense network of points of known X, Y, Z coordinates. It includes natural terrain features, vegetation, roads, buildings etc. Triangulation Irregular Network (TIN) are favoured for DEM modelling. Delaunay triangulations are used to create the best conditioned triangular network. DEM input required to generate surfaces for engineering design can be ordered (grids), semi-ordered (profiles or contours) or random pointing.
- DTM (Digital Terrain Model) is a filtered version of DEM and contains the “bare Earth”.

Uses of DEM and DTM

- DEM can be used for:
 - ✓ Landscaping
 - ✓ City modelling
 - ✓ Visualization applications.
- DTM can be used for
 - ✓ Flood modelling (from contour lines)
 - ✓ Drainage modelling (from contours and cross sections)
 - ✓ Land use studies
 - ✓ Slope models or volume calculations (from cross sections).

3.3 Application: Road Design

Design of new roads will generally fall into either (i) roads following existing routes, e.g., those involved with either upgrading of an existing road or a short deviation or (ii) roads following new routes, e.g., those roads linking two points for the first time. For road design along existing routes, a *cross section* survey of the existing road is generally carried out as a

first step in the design. This survey includes, e.g., road cross sections every 25m along the formation where the measured locations will include:

- ✓ Centre line, edge of bitumen, edge of formation, bottom of drain, top of drain, any other changes of grade, fence, etc.
- ✓ Road furniture (to all fixtures in the road and road reserve).
- ✓ Improvements such as buildings and bridges.

In the example of Australia, a road design for an existing route will generally be undertaken in 3 stages as follows:

1. **Stage 1** (Horizontal Control, see Chapter 5) - Control points are placed approximately every 250 m in the existing bitumen road and connected to Australian Map Grid (AMG) via adjacent Standard Surveying Marks (SSM's). The requirements are generally traverses with an accuracy of 1:10,000 to 1:20,000 or better (Chapter 5).
2. **Stage 2** (Vertical Control, see Chapter 2) - Control points are connected to the Australian Height Datum (AHD) via adjacent Bench Marks. The requirements are generally a level traverse with an accuracy of $12\text{mm}\sqrt{k}$, where k is the traverse distance in kilometres.
3. **Stage 3** (Detail Survey) - A cross sectional survey is carried out every 20 m along the alignment of the road. From the control points established in stages 1 and 2 above, an EDM radiation survey of not more than 125 m is carried out. Distance and angular measurements are undertaken together with the heights of the instrument and target. From these measurements, a topographical map showing features and contours/cross sections can be generated. It should be pointed out that these types of surveys could be carried out using GPS surveying (Chapter 10). For Australia, the main roads department (MRD; www.mainroads.wa.gov.au) has formulated a set of procedures covering a cross section survey of this nature.

3.4 Calculation of Road Cross Sections in Cut and Fill Operations

The calculation of road cross section area is presented as a series of materials developed for the Curtin University Civil Engineering Surveying workshops (see Appendix A1-2) to try to distil and simplify material presented in standard text books. A simplified profile of an embankment, in either cut or fill, is used as an illustration. See Figure 3.2.

The basic components of embankment design are:

1. Pavement, design width. This is given the label **b**. It is symmetrical about the centre line.
2. Design finish level of the formation centre line, the datum.
3. Surface level at formation centre line.
4. The difference between centreline design finish level and surface level, either the depth of cut or fill, **h**.
5. The formation **batter** slope, the constructed gradient of the cut or fill operation, labelled **m**. The slope is expressed as a **rise** and **run** ratio of **1:m.**, e.g. 1:3 means that for every vertical change in height there will be a 3-fold increase in horizontal deviation. Normally the batter slope, **m**, is designed to mimic the natural repose of the formation construction material. In road construction using natural materials the slope may be different for cut operations as opposed to fill.
6. The **cross fall** of the natural surface from the design centre line is designated **k**, and goes outwards beyond the batter slope intercepts. For calculations, **k** has a sign such that **+k** represents a **rise** from the centreline outwards while **-k** represents a **fall** from the centreline outwards. If there is **no** cross fall, then the slope is **flat**, and **k = 0:1** or **k** $\rightarrow \infty$ (**k** = 10,000 will suffice in general calculations).

7. Formation width, the distance from the centreline at which the batter slope intercepts the surface is designated w and expressed as a distance left, w_L , and right, w_R , of the centreline. The formation width depends on h , $b/2$, m and k .

The calculations are expressed as distances either side, **left** or **right** of the centre line. The designation of left and right is taken in the sense of observing in the direction of the centreline progress, i.e., of increasing chainage. Figure 3.2 shows the definitions given above for a section in fill. Note that the cross section distances are measured horizontally away from the centreline. The vertical distances are labelled, in this case, from some arbitrary vertical datum starting at 10.0. The finish level is at 10.3 and the centre line surface level is about 10.08. Thus $h = 0.22$.

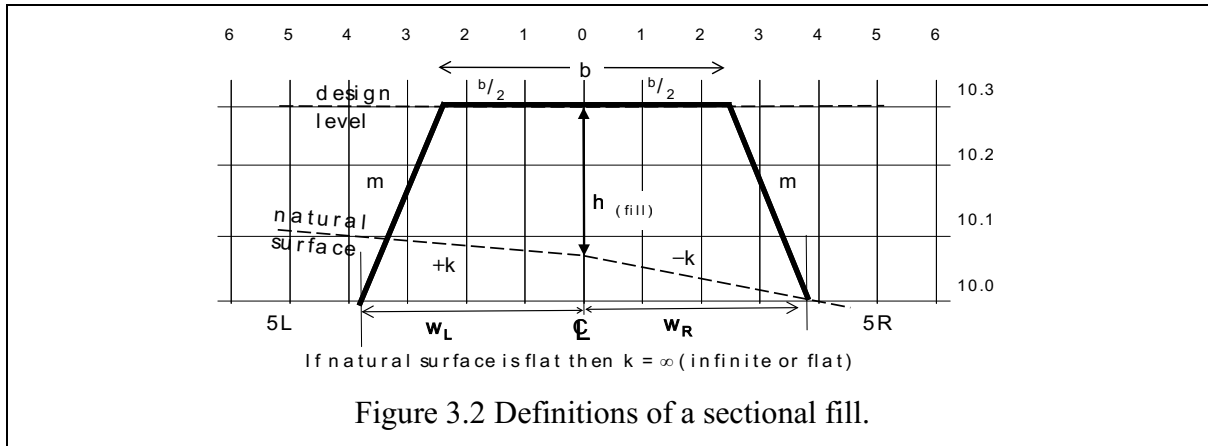

Figure 3.2 Definitions of a sectional fill.

Cross section diagrams are often shown with a **vertical exaggeration** which helps to illustrate the formation section. In Figure 3.2 a vertical exaggeration of 10:1 is evident. Vertical exaggeration at a nominated scale also allows one to plot the road section, showing natural surface and the pavement width at design level. By plotting the formation batters (at the exaggerated scale) it is possible to scale off the formation width intercept with the natural surface.

3.4.1 Calculation of Cut Formation Width w_L , and, w_R , Flat Ground

The development of the calculation of formation width will start with a cut embankment referenced to a flat natural surface (Figure 3.3).

The design components are:
 pavement width, $b = 5$
 batter slope, $m = 3$,
 depth (cut/ fill), $h = 0.25$,
 cross slope is **flat**,
 k is ignored.

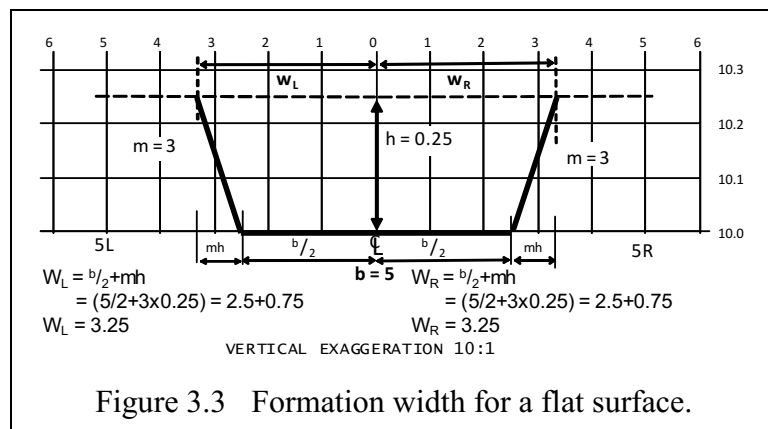

Figure 3.3 Formation width for a flat surface.

3.4.2 Calculation of Formation Width, w_L , and, w_R , Incorporating Cross Fall. Sloping Ground

Figure 3.4 introduces surface slope, k , that needs to be taken into account to determine formation width w_L and w_R . It is obvious from the exaggerated diagram that, compared with a level surface, the batter width has to increase as we “chase” an upward (k positive) slope to inter-

cept the ground. Likewise, the batter width will decrease against falling (k negative) slope. How so?

Derivation of formation width incorporating cross fall.

In the diagram, Figure 3.4:

$$A_1B = \frac{w_1}{k_1}$$

The difference in height between the ground at the centreline and the formation batter intercept is due to the slope of $1:k$ over the distance w_1 .

Similarly: $C_1B = \frac{w_2}{k_2}$

The extended batter, of slope m , over a horizontal base of $b/2$ intercepts the centreline at G with a height:

$$GE = \frac{b}{2m}$$

Triangles AA_1G and FEG are similar. Thus, using similar triangles:

$$\frac{AA_1}{FE} = \frac{GA_1}{GE} \text{ and substituting:}$$

$$\frac{w_1}{b/2} = \left\{ \frac{\frac{b}{2m} + h + \frac{w_1}{k_1}}{b/2m} \right\} \Leftrightarrow w_1 = m \left[\frac{b}{2m} + h + \frac{w_1}{k} \right]$$

$$w_1 = \left(1 - \frac{m}{k} \right) = \frac{b}{2} + mh \quad \text{Thus}$$

$$w_1 = \left(\frac{b}{2} + mh \right) \left(\frac{k}{k - m} \right).$$

If the denominator is less than the numerator, then

$$\left(\frac{k}{k - m} \right) > 1.$$

Note that the slope of k has been taken as positive. If the slope is falling from the centre line (making $w < b/2 + mh$) we thus must have to express w_2 as:

$$w_2 = \left(\frac{b}{2} + mh \right) \left(\frac{k}{k + m} \right)$$

If the denominator is greater than the numerator, then $\left(\frac{k}{k + m} \right) < 1$.

This then means applying one of the two rules, determined by inspection of k , for a rising or a falling slope from the centre line.

However, if we apply the **sign** of the slope to k then we can express the left and right formation widths with one formula:

because, $w_{L/R} = \left(\frac{b}{2} + mh \right) \left(\frac{k}{k - m} \right)$ and, if k is negative then:

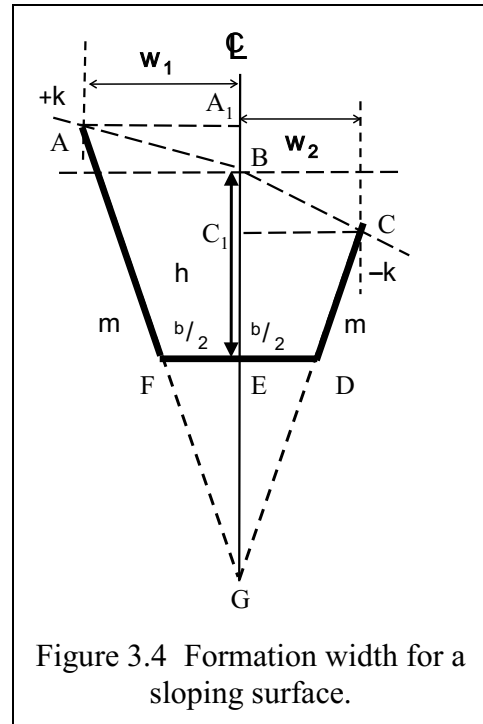

Figure 3.4 Formation width for a sloping surface.

$$w_{L/R} = \left(\frac{b}{2} + mh\right) \left(\frac{-k}{-k-m}\right) \Leftrightarrow \left(\frac{b}{2} + mh\right) \left(\frac{k}{k+m}\right)$$

This returns to the original statement for w_2 , as stated above, where the slope is falling from the centreline. It is best to have only **one** formula to work with, and use the **sign** of k to

control the denominator. $w_{L/R} = \left(\frac{b}{2} + mh\right) \left(\frac{k}{k-m}\right)$

3.4.3 Calculation of Formation Width, w_L , and, w_R , Constant Cross Fall Ground

The development of the calculation of formation width now moves on to calculating formation width against a constantly sloping natural surface (Figure 3.5).

In the Figure 3.5 the cross slope has been calculated from a level profile measured in the field:

- 10.5 RL at 5m Left
- 10.25 RL centreline
- 10.0 RL at 5m Right

The slope k is calculated using run/rise **from** the centreline:

$$k_L = 5/(10.5 - 10.25) = 5/0.25 = 20,$$

- a **rise** away from the centreline, and similarly

$$k_R = 5/(10.0 - 10.25) = 5/-0.25 = -20,$$

a **fall** away from the centreline.

The components of the design are:

- pavement width, $b = 5$
- batter slope, $m = 3$
- depth (cut or fill), $h = 0.25$
- cross slope is **1:20**, $k_L = +20$, $k_R = -20$.

Applying the formula

$$w_{L/R} = \left(\frac{b}{2} + mh\right) \left(\frac{k}{k-m}\right) \text{ results}$$

in $w_L = 3.84$ and $w_R = 2.83$.

The calculation of w_L and w_R are shown in the Figure 3.6 and Figure 3.7, demonstrating the operation of the **sign** of k in the results.

3.4.4 Calculation of Formation Width, w_L , and, w_R , Varying Cross Fall Ground

The development of the calculation of formation width then moves on to calculating formation width against a varying sloping natural surface (Figure 3.6).

In Figure 3.6 the cross slope has been calculated from a level profile measured in the field:

- 10.35 RL at 5m Left
- 10.25 RL centreline

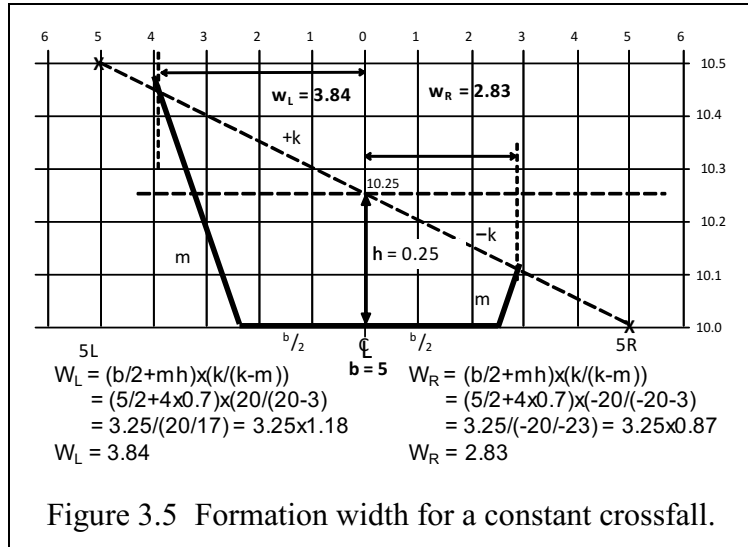

Figure 3.5 Formation width for a constant crossfall.

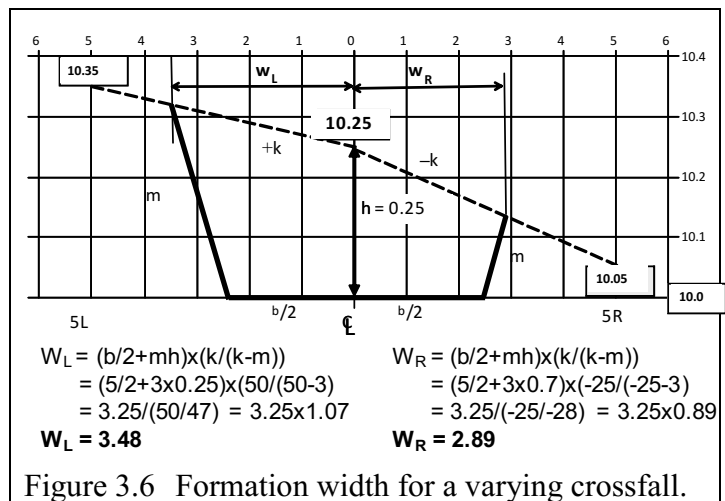

Figure 3.6 Formation width for a varying crossfall.

10.05 RL at 5m Right
Slope **k** is calculated using run/rise **from** the centreline:

$$k_L = 5 / (10.35 - 10.25) = 5 / 0.1 = 50,$$

- a **rise** away from the centreline, and similarly

$$k_R = 5 / (10.05 - 10.25) = 5 / -0.2 = -25,$$

- a **fall** away from centreline.

The components of the design are:

- pavement width, **b** = 5
- batter slope, **m** = 3
- depth (cut or fill), **h** = 0.25
- cross slope varies, **k_L** = +50, **k_R** = -25.

Applying the formula $w_{L/R} = \left(\frac{b}{2} + mh\right) \left(\frac{k}{k-m}\right)$ results in **w_L** = 3.48 and **w_R** = 2.89.

Another case to consider is where the depth, **h**, is such that the batter intercept falls outside the first cross section.

3.4.5 Batter Width Falls Outside the First Cross Section

Calculations with varying different cross falls.

In Figure 3.7, the batter intercept, **w_L** = 5.78m, using **k**=50, is between 5L and 10L. As the field notes reveal, RLs at:

- 10L = 11.3.
- 5L = 10.8
- CL = 10.7

Datum = 10.0

The resultant slopes, from CL to 5L (**k_{L1}**) and 5L to 10L (**k_{L2}**) are:

$$k_{L1}(CL - 5L) = 5 / (10.8 - 10.7) = +50$$

$$k_{L2}(5L - 10L) = 5 / (11.3 - 10.8) = +10.$$

What is the height of the batter slope above the datum at profile offset 5L?

Find the height at which a batter of **m** = 4 intercepts the 5L cross section.

Here **b** = 5, so **b/2** = 2.5.

From the edge of the formation the batter slope rises from 2.5L at slope of

m = 4 until it intercepts 5L, a distance of 2.5m. See Figure 3.8.

As **w** = **mh** then

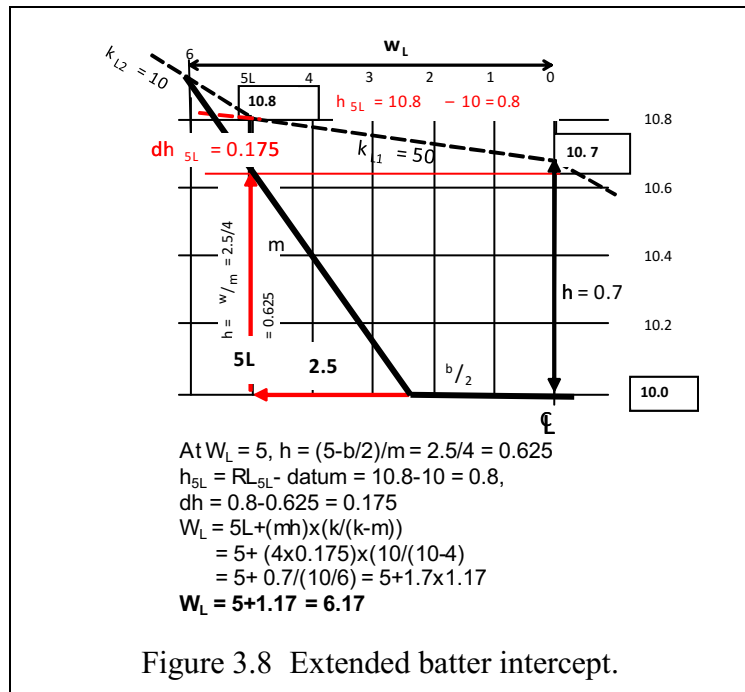
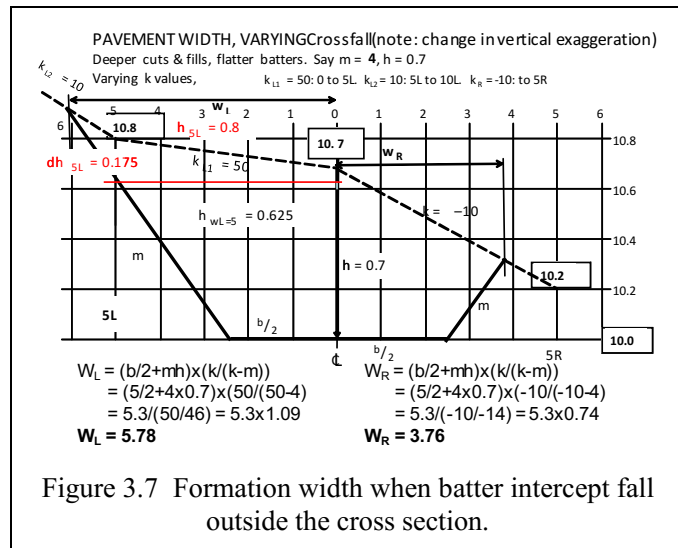

$$h = w/m$$

The batter intercept with 5L is at a height:

$$h_{wL=5} = 2.5/4 = 0.625 \text{ at } 5L.$$

Turning to the design:

h_{5L} is the surface height at 5L above the design datum.

From field book and design level $h_{5L} = (10.8 - 10.0) = 0.8$

The depth of the batter intercept at 5L, called dh_{5L} , between the 5L surface and the 5L batter intercept is:

$$dh_{5L} = 0.8 - 0.625 = 0.175$$

below the surface at 5L.

What is the formation width increment, dw_L , from 5L, where the batter is still below the slope, to the rising $k_{L2} = +10$ slope surface intercept?

Reiterating: $dh_{5L} = 0.175$

$$k_{L2} = +10$$

$$m = 4$$

dw_L is then calculated using the formula

$$\begin{aligned} dw_L &= (m \, dh_{5L})(k_{L2}/(k_{L2} - m)) \\ &= (4 \times 0.175)(10/(10-4)) \end{aligned}$$

$$dw_L = 1.17.$$

Total $w_L = w_{L=5} + dw_L$

$$= 5 + 1.17 = 6.17 \text{ as shown in Figure 3.7 and Figure 3.8.}$$

3.4.6 Derivation of AREA Formula using Formation Widths

Having calculated the formation widths, w_L and w_R , it is a simple matter to calculate the AREA of the section.

A **CONSTANT** slope is assumed from the batter intercept to the centreline. Individual slopes, k , can vary as they only affect the formation widths w_L and w_R .

In practical terms **assuming** a constant slope makes little difference to the calculated area compared with methods that more closely follow the surface profile, which rely on using a matrix determinant method. In Figure 3.9;

$$\text{Area } ABCDFA = \text{Area } ABG + \text{Area } CBG - \text{Area } DFG$$

$$= \frac{1}{2} w_1 (h + EG) + \frac{1}{2} w_2 (h + EG) - \frac{1}{2} FD \cdot EG$$

$$EG = \frac{b}{2m}, \quad FD = b$$

$$= \left\{ \frac{1}{2} w_1 \left(\frac{b}{2m} + h \right) + \frac{1}{2} w_2 \left(\frac{b}{2m} + h \right) \right\} - \frac{1}{2} b \left(\frac{b}{2m} \right). \text{ Factor out the } \left(\frac{1}{2} \right)$$

$$= \frac{1}{2} \left(\left(\frac{b}{2m} + h \right) (w_1 + w_2) - \frac{b^2}{2m} \right). \text{ Factor out the } \left(\frac{1}{m} \right)$$

$$\text{Area} = \frac{1}{2m} \left(\left(\frac{b}{2} + mh \right) (w_1 + w_2) - \frac{b^2}{2} \right)$$

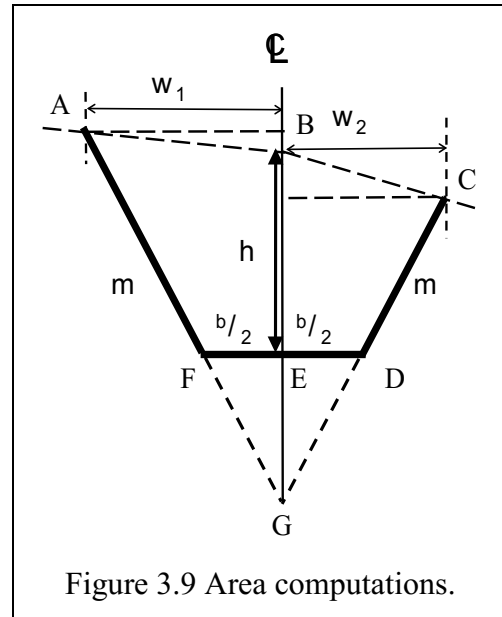

Figure 3.9 Area computations.

Note the process.

You have to calculate $\left(\frac{b}{2} + mh\right)(w_1 + w_2)$, subtract $\frac{b^2}{2}$ and then divide the result by $\frac{1}{2m}$.

Using the values in Figure 3.6,

$$\text{Area} = \frac{1}{2 \times 3} \left\{ \left(\frac{5}{2} + 3 \times 0.25 \right) (3.46 + 2.9) - \frac{5^2}{2} \right\} = \frac{1}{6} \{ (3.25)(6.36) - 12.5 \} = 1.36$$

3.4.7 Area by Matrix Determinant

Referring to Figure 3.10, we can see that the section provides an XY coordinate set if we can determine the h_L and h_R above the datum.

Having determined w_L and w_R , we can then calculate the height of the batter intercept with the ground slope above the datum level.

Basically $w = mh$

($b/2$ merely allows for the formation width; k introduces the effect of slope.)

Now $w = b/2 + mh$,

thus $w - b/2 = mh$, and

$h = (w - b/2)/m$.

Following Figure 3.10, the XY coordinates of the cross section can be tabulated:

Remember, centreline is at $w = 0$.

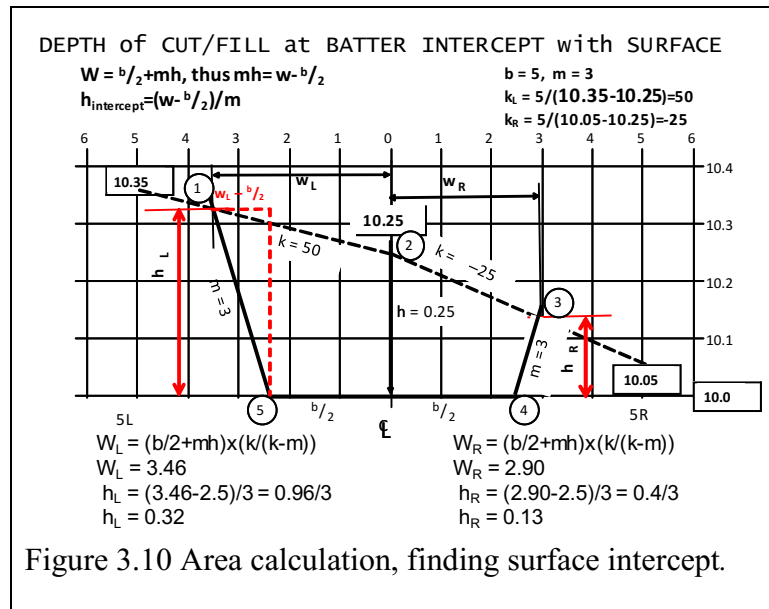

$$2 \text{Area} = \sum_{p=1}^n (X_p Y_{p+1} - Y_p X_{p+1})$$

This method produces **2 AREA**. So:

$$\text{Area} = \frac{1}{2} \left(\sum_{p=1}^n (X_p Y_{p+1} - Y_p X_{p+1}) \right)$$

And remember to **close** back to the start point.

{w, h} represents the {X, Y} coordinates above the datum in Figure 3.10.

Point	w	h above datum	Matrix determinant method
1	-3.46	0.32	w_L, h_L
2	0.0	0.25	CL, h
3	2.9	0.13	w_R, h_R
4	2.5	0.0	$b/2_R$, datum
5	-2.5	0.0	$b/2_L$, datum
1	-3.46	0.32	w_L, h_L (return to 1)

All the zero elements drop out.

$$\begin{vmatrix} -3.46 & 0.32 \\ 0.0 & 0.25 \\ 2.9 & 0.13 \\ 2.5 & 0.0 \\ -2.5 & 0.0 \\ -3.46 & 0.32 \end{vmatrix} \begin{matrix} \rightarrow \Sigma_{+ve} \mathbf{2 Area} = \\ \rightarrow (-3.46 \cdot 0.25 + -2.5 \cdot 0.32) \\ \rightarrow - (2.9 \cdot 0.25 + 2.5 \cdot 0.13) \\ \rightarrow -1.66 - 1.05 = -2.71 \\ \rightarrow \Sigma_{-ve} \text{ taking absolute value:} \end{matrix}$$

$$\text{Area} = \frac{1}{2} 2.71 \text{m}^2 = 1.36$$

3.5 Calculation of Embankment Volume from Road Cross Sections in Cut and Fill Operations

After calculating the various cross section areas there are a number of ways to find the volume of the earthwork.

a) Calculation of volume from mean areas.

Volume = V = $\left(\frac{A_1 + A_2 + A_3 \cdots A_{n-1} + A_n}{n}\right) \cdot L$. The method is **not** recommended.

b) Calculation of volume from end areas. This is the recommended method for the practical exercise in Appendix A2.

Volume = ΣV = $D_{12}\left(\frac{A_1 + A_2}{2}\right) + D_{23}\left(\frac{A_2 + A_3}{2}\right) + D_{34}\left(\frac{A_3 + A_4}{2}\right) + \dots$.

And where D is the common distance **between** sections

Volume ΣV = $D\left(\frac{A_1 + A_n}{2} + A_2 + A_3 + \dots + A_{n-1}\right) \Rightarrow \frac{D}{2}(A_1 + A_n + 2A_2 + 2A_3 + \dots + 2A_{n-1})$

c) Calculation of volume from Simpsons Rule. You need an ODD number of sections.

Volume ΣV = $\frac{D}{3}(A_1 + 4A_2 + 2A_3 + 4A_4 \cdots 2A_{n-2} + 4A_{n-1} + A_n)$.

It is a variation of the prismoidal formula.

n must be an **odd** number of sections.

D is the distance **between** sections.

3.6 Plan Scale, Horizontal and Vertical

For plan drawings to be constructed on paper the **scale** is defined as the representation of the relationship between a unit of measure on the paper and the unit of measure on the ground.

It is a **representative** fraction between the paper units and the ground units.

a scale of 1:1000 means that 1mm on paper = 1000mm (1m) on the ground.

For example, the mining practical exercise area at Curtin University (Australia) is about 120m x 110m wide. The gridded area is about 80m x 60m wide.

The Civil Engineering grid exercise area is 100m x 40m.

An A4 paper sheet is 297 mm x 210 mm from which about 10 mm margin must be excluded. Thus, the drawing area is about 275 mm x 190 mm. You must also make allowance for the title blocks, revision panels, scale bars etc.

In reality the plotting area is about 250mm x 190mm

At a scale of 1:400 this represents an area of 100m x 76m;

at a scale of 1:500 this represents an area of 125m x 95m

To be presented on an A4 sheet of paper at a scale of 1:500 the plan size will be:

1 m = 1000 mm/500 = 2.0 mm,

a tree of diameter 600mm = 1.2mm (can you draw a 0.6mm radius?)

0.1 m = 100 mm/500 = 0.2 mm. This is below the limit of hand plotting.

The engineering plan can thus be presented at 1:400, but the mining site plan would have to be trimmed in width (the E/W extent) to fit at 1:500. An A3 sheet, inserted in landscape orientation and Z folded to A4, provides scope for larger areas.

A triangular scale rule, Staedtler MARS 561 98-4 or similar, with scales of 1:100, :200, :250, :300, :400 and 1:500 is recommended for hand plotting.

3.7 Vertical Exaggeration

It can be seen from the previous discussion on embankments that, compared with the width of an embankment, the depth can be small.

At a scale as large as 1:200 a full batter width of 6.8 m = $6800/200 = 34$ mm.

However, the corresponding depth of 0.3 m at the same scale = $300/200 = 1.5$ mm.

This is extremely difficult to plot, and almost impossible to measure to extract cross section data.

By having a vertical exaggeration of, say, 10:1 then the vertical scale = 1:20. Thus the depth of 0.3 m = $300/20 = 15$ mm. This is a much easier profile to draw. Figure 3.11.

However, you can only use vertical exaggeration in profile (elevation) drawings. Any **plan** drawings must use the same scale in both the X and Y axes.

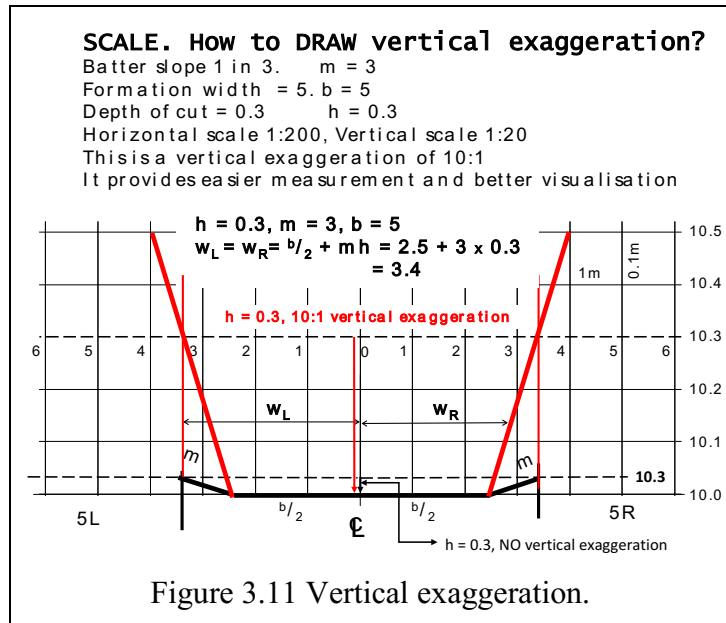

3.8 Plan Sketching and Drawing

The ability to present hand drawn plans is of great importance in the presentation of initial observations. A neat, accurate field sketch, produced without resort to CAD programs, enhances the understanding of field data by its immediacy.

The tools of trade are: 1) a 360° protractor; 2) a well graduated ruler; 3) a good compass for arcs and circles; 4) 30° and 45° triangles; 5) pencils and eraser. Good blank paper is essential, and accurately printed graph paper is handy. (Photocopies of graph paper result in grid shrinkage; thus the scale plots incorrectly.)

The field sketch drawings in a field book don't have to be any particular scale, but the ratio between measured distances should be maintained so that the drawing is conformal. If you make a scale of 80mm = 105m then 75m is about 60mm (57). This example (105/0.08) has a scale of 1:1312 which can be stored in a calculator memory for use during the sketch.

Use the protractor aligned, generally, with a reasonable North. Align the directions accurately. You can then read angles which will help with the reduction of observations, especially of directions either side of 360°. For a radiation (side shot) drawing, the protractor can be fixed over the observation point, directions radiated and then, the protractor removed, the distances to points scaled in with the ruler.

3.9 Calculation of Embankment Volume from Batter Slopes: Mining

3.9.1 Batters, Ramps and Benches.

As an introduction to mine and civil earthworks development you should have studied engineering mechanics, geology, and mechanics of solids. Mining geomechanics and mine geotechnical engineering come later in your course. This introduction to the surveying side of batter slopes will give some mathematical tools for batter design. Correctly calculated and constructed batter slopes are an integral part of slope stability. As an engineer and a manager you will be responsible for the design and implementation of mine walls in both cut and fill

operations. As such, the calculation of slopes, areas and volumes follows the formulas used in road design.

In open pit design (Figure 3.12), the main question to be answered is the origin of design boundary.

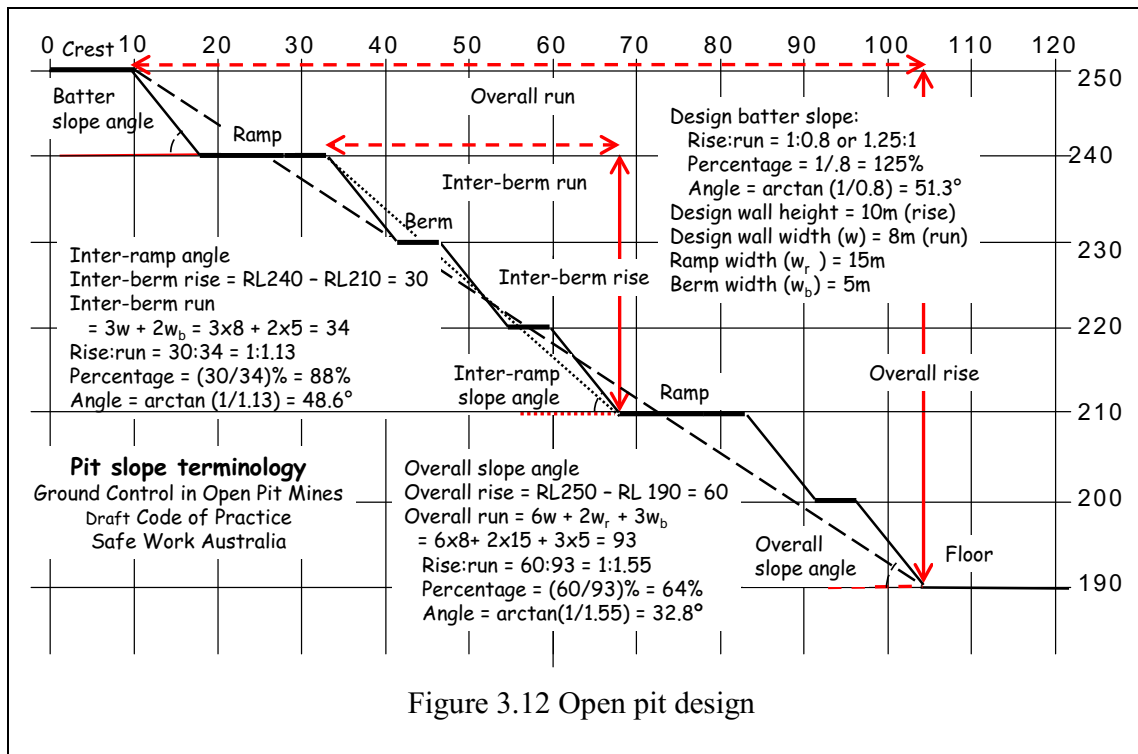

Figure 3.12 Open pit design

Does the design start at the ground level crest boundary?

If so, the distance to the toe of the batter will depend on the depth to a bench, and the design batter slope either in slope, 1:m, percentage or angle values.

In Figure 3.12, the batter slope angle, the resulting inter-ramp slope angle, and the final overall slope angle are quite different.

Berm width is concerned with pit wall safety and is designed to contain hazardous rock falls, prevent material spillage on to lower levels, provide access to the slope wall and access to surveying and stability monitoring points. Once bench blasting has commenced, the berm may be incorporated every 10 to 20 metres, depending on material stability. Berm heights of 30m may be acceptable in massive stable formations.

Ramp width is determined by traffic requirements. Haul trucks, excavators and large machinery must have access to the mine works. The ramp width would also incorporate some of the berm functions. The ramp inclination and routing is a specialist design area.

The width of the road will depend on the width of the largest vehicle to use the road. Is it single or dual lane, straight or curved? A curved, dual lane road for a mid-sized off highway truck would incorporate an allowance for vehicle overhang and a width expansion factor to the truck width. Standard practice is to then add an allowance for wind-rows on either side to allow road maintenance as well.

So, a mid-sized off-highway truck, 100t capacity is likely to be 6.9m wide. A 20% width factor and dual road spacing will require nearly 30m road width, plus 10m of windrow. The largest, +300t payload, trucks are about 10m wide and would require a total width of over 50m.

Maximum grade in-pit is about 10%, has a slope of 1:10 which is about 5.7° .

3.9.2 Calculate Cross Section Areas for Volume: Mining

The Field Practical survey area is of restricted size. However, it allows the collection of data, which can demonstrate the principles of computations used in engineering and mining.

In Field Practical 2, ground levels are determined by using the grid intersections representing a drill and blast field. Typically blasting is carried out on a 6m by 7m grid (personal communications with AusIMM).

The data collected can form cross sections, the datum of which is specified by a bench level.

The **crest boundary** set for the excavation is the 350E grid line and the 7500N grid line (Figure 3.13).

From field booking, cross sections for the nominated sections can be generated.

Figure 3.13 shows alternate cross sections and the inferred toe of the batter for a slope of 1:1.25 (39°) from the crest to the bench level of 15.5m.

The task is to calculate the volume bounded by the surface, the batter slope and the bench.

Remember, the blast grid is on a 6m x 7m pattern.

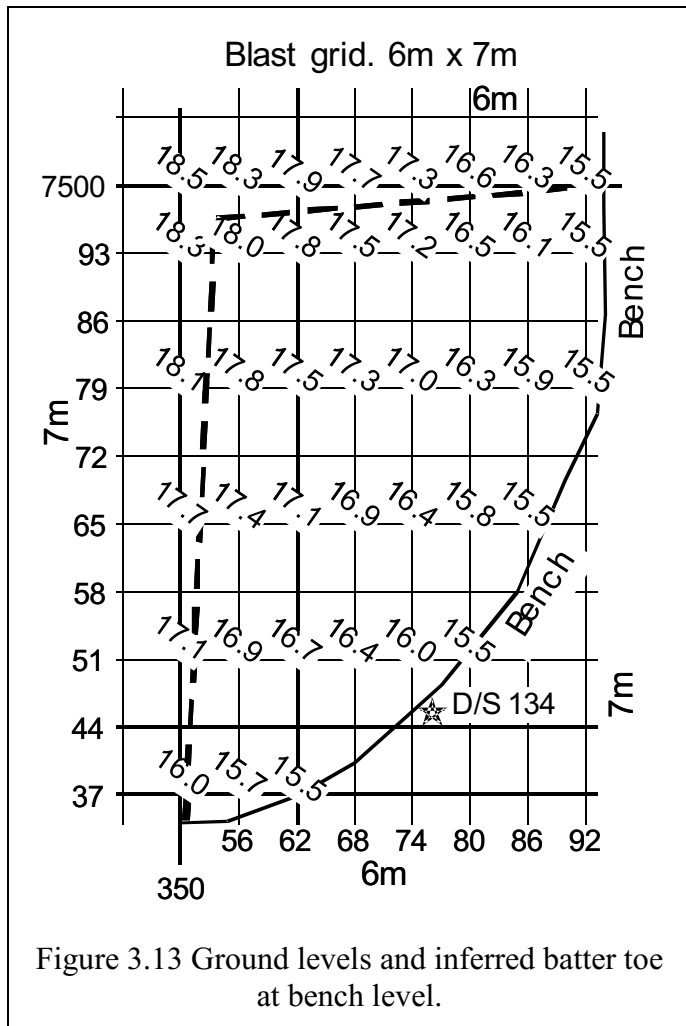

Figure 3.13 Ground levels and inferred batter toe at bench level.

3.9.2.1 Generate Cross Sections

Taking the 7493N section (Figure 3.14). The crest boundary set at 350E.

The RL is 18.3 m

The height to bench is 2.8m, the toe of the batter is located at 353.5E. Ground RLs provide the Y ordinate and the grid E value provides the X ordinate.

Note the vertical exaggeration and offset datum for height. A horizontal scale of 1:250 will make the X axis (45 m) a maximum width of 180 mm at 7493N.

A vertical scale of 1:50 and a height of 3m will require a vertical axis of 60 mm

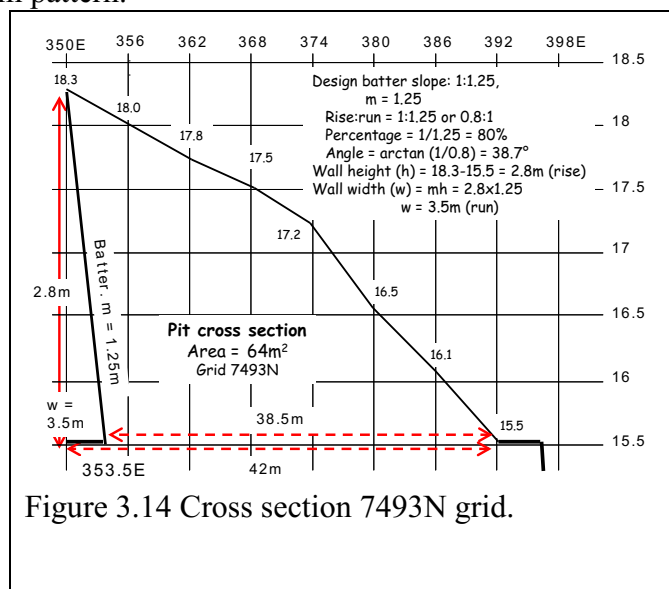

Figure 3.14 Cross section 7493N grid.

3.9.2.2 Area by Matrix Determinant

Using the matrix determinant method in Section 3.4.7, the area of the section 7493N is calculated as 64 m². Instead of using “raw” coordinates for the matrix, it may be easier to use translated offsets, i.e.,

350, 18.3 ↔ 0, 2.8

356, 18.0 ↔ 6, 2.5.

362, 17.8 ↔ 12, 2.3

etc. (see dE and h in Table 3-2), just a datum shift.

Table 3-2 shows the process of producing the same result for both actual and shifted coordinates.

Again, note the vertical exaggeration and offset datum for height. A horizontal scale of 1:250 will make your X axis (35 m) a maximum width of 140 mm at 7451N.

A vertical scale of 1:50 and a height of 2 m will require a vertical axis of 40 mm.

Similarly, at section 7451N, the observed profile provides a section area of 27 m².

Taking the 7451N section (Figure 3.15) and the crest boundary set at 350E the RL is 17.1 m.

The height to bench is 1.6 m, the toe of the batter is located at 352E. Ground RLs provide the Y ordinate and the grid E value provides the X ordinate.

Taking the E/W section lines, the following cross section areas have been calculated: using the mean end area, the volume between each pair of grid lines is calculated and summed in Table 3-3. Remember, the grid spacing is 7m proceeding south from 7500N, the table has been abbreviated by using every second grid line below 7493N. Cross grid levels are taken every 6m from 350E eastwards.

Refer to Section 0 for methods of volume calculation.

3.9.2.3 Batter Slope at 7500N

The volume calculated so far allows for the batter on the 350E crest line. There is also the batter slope projecting into the excavation from the 7500N section (Figure 3.16). We now make allowances for the volume of material left by the batter associated with the excavation from the bench to the crest of the 7500N grid line.

What about the batter to the 7500N crest line?

Table 3-2 Area by matrix multiplication.

E	RL	+ve	-ve	dE	h	+ve	-ve
350	18.3		6515	0	2.8		17
356	18.0	6300	6516	6	2.5	0	30
362	17.8	6337	6550	12	2.3	14	41
368	17.5	6335	6545	18	2.0	24	48
374	17.2	6330	6536	24	1.7	30	51
380	16.5	6171	6369	30	1.0	24	36
386	16.1	6118	6311	36	0.6	18	25
392	15.5	5983	5479	42	0.0	0	0
353.5	15.5	6076	5425	3.5	0.0	0	0
350	18.3	6469		0	2.8	10	
		56119	56246			Sums	120 248
		Half difference = 64				Half difference = 64	

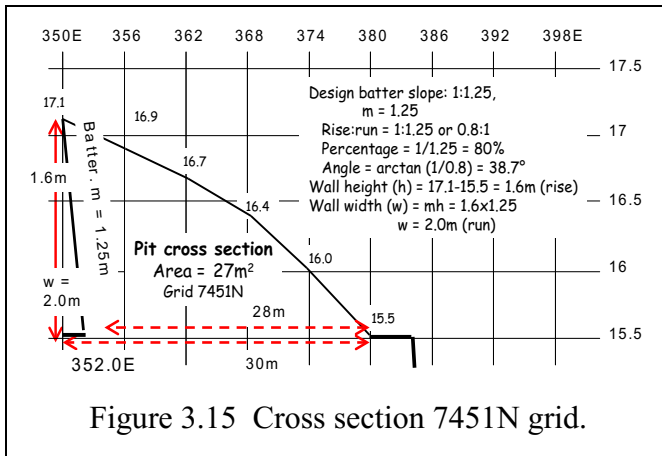

Figure 3.15 Cross section 7451N grid.

Table 3-3 Areas and volume.

Grid	Area	Grid Spacing	Vol
7500	70		
		7	470
7493	64		
		14	840
7479	56		
		14	672
7465	40		
		14	469
7451	27		
		14	210
7437	3		
		Sum volumes	2661

How can we provide for the volume of material left behind the batter to the bench?

One way would be to calculate the area of each triangle at each cross section between 350E and 398E, where the bench is exposed.

Your field book calculations will provide the difference in height, **h**, at each grid E. Since we know the batter slope, **m**, and, using the stockpile example, the triangle area is $\frac{1}{2}h^2m$. Calculated values for the grid areas and the volume are shown on Figure 3.17.

The volume of the batter is about 99 m³, shown in Figure 3.17. Subtracting this value from Table 3-3 results in an excavation volume:

$$- 2661 - 99 = 2562 \text{ m}^3.$$

Note that this value is the in-situ volume. The material to be excavated will be subject to a bulking, or “swell”, factor for transport. The batter in our example is predicated on a stable rock material. Common values of bulking factor for “rock” are between 40% and 80%. Thus the 2600 m³ could bulk out to some 4,000 m³, depending on your blast effort.

Figure 3.16 is a diagram of the batter associated with the 7500N crest.

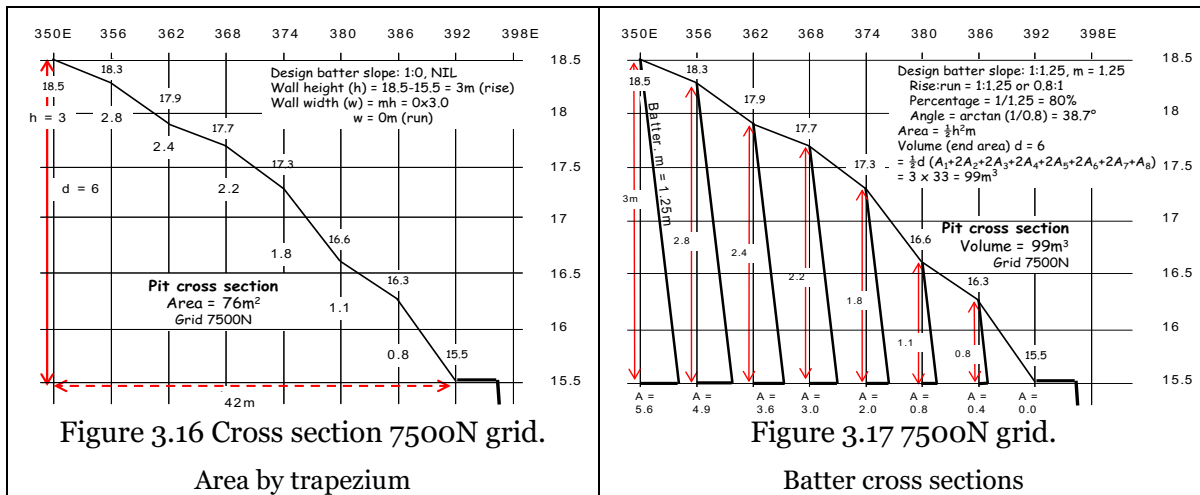

Figure 3.17 shows the batters from the floor of the excavation to the crest of the 7500N grid line. The area of each triangle is shown on the X axis.

The preceding calculations show that excavation volume calculations are not that hard. The example is not designed to replace the methods presented in other formal mining engineering units.

3.9.3 Cross Section Area by Trapezium

An alternate approach to calculating area is to obtain the area of each **trapezium** formed between the adjacent grid lines.

At the 7493N cross section, Figure 3.14, it can be seen that each pair of E grids form a trapezium.

Each E grid line has its associated depth to bench, **h**, calculated by subtraction bench level (15.5m) from ground level as shown as in Figure 3.14.

$$h_{350} = 18.3 - 15.5 = 2.8, h_{356} = 18.0 - 15.5 = 2.5; h_{362} = 2.3, h_{368} = 2.0, h_{374} = 1.7, h_{380} = 1.0, h_{386} = 0.6, h_{392} = 0.$$

Area of trapezium = $Area = \frac{1}{2}d(h_n + h_{n+1})$, where **d** is the column spacing (6m on this grid).

$$A = 3(2.8+2.5) + 3(2.5+2.3) + 3(2.3+2.0) + 3(2.0+1.7) + 3(1.7+1.0)+3(1.0+0.6) + 3(0.6+0) = 69m^2.$$

Incorporating batters requires the subtraction of $\frac{1}{2}h^2m$ from each cross section area.

$$A = \frac{1}{2}h^2m = \frac{1}{2} \cdot 2.8^2 \cdot 1.25 = 4.84 \cdot 1.25$$

$$\text{Area batter} = 4.9$$

$$\text{Section area} = 69 - 4.9 = 64 \text{ m}^2, \text{ agreeing with the area calculated in Fig. 3.14.}$$

Again, the volume is calculated by the end area method in Section 3.4.7 for all the cross sections. And the volume of the batter to the crest of 7500N has to be excluded as shown in Section 3.9.2.3.

3.9.4 Block Volume

Another approach to calculating volume is to calculate the volume of each **block** formed between the adjacent grid plans. The approach is to find the volume of a block by calculating the mean height (depth) of each grid area, multiplied by the area itself.

A block volume calculated by grid depths.

Taking blocks 1 – 4, 8, 9, 15, 16 in Figure 3.18.

Taking a section of the area for volume calculations:

Volume block = average depth x area

$$V = \frac{\Sigma (\text{vertices})}{4} \times A \text{ or } \frac{\Sigma (\text{vertices})}{4} \times A/4$$

$$V_1 = (3 + 2.8 + 2.5 + 2.8) \times (6 \times 7)/4$$

$$= 11.1 \times 10.5 = 116.6, \text{ similarly}$$

$$V_2 = (2.8 + 2.4 + 2.3 + 2.5) \times 10.5 = 105.0,$$

$$V_3 = (2.4 + 2.2 + 2.0 + 2.3) \times 10.5 = 93.4$$

$$V_4 = (2.2 + 1.8 + 1.7 + 2.0) \times 10.5 = 80.8$$

$$V_8 = (2.8 + 2.5 + 2.4 + 2.7) \times 10.5 = 109.0$$

$$V_9 = (2.5 + 2.3 + 2.2 + 2.4) \times 10.5 = 98.7$$

$$V_{15} = (2.7 + 2.4 + 2.3 + 2.6) \times 10.5 = 105.0$$

$$V_{16} = (2.4 + 2.2 + 2.0 + 2.3) \times 10.5 = 93.4$$

$$\text{Total volume} = 802.2 \text{ m}^3.$$

It can be seen that a number of the depths have been used repeatedly for each block. As with the end area method of calculating volumes, so a method can be articulated for the calculation of block volume.

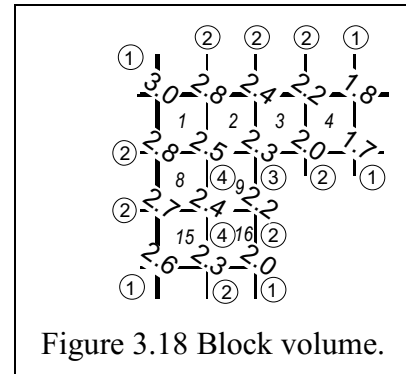

Figure 3.18 Block volume.

$$\text{Volume} = (\text{single grid area})/4 \times \{(\Sigma \text{ depths used once}) + 2(\Sigma \text{ depths used twice}) + 3(\Sigma \text{ depths used thrice}) + 4(\Sigma \text{ depths used four times})\} + \Sigma V.1$$

Figure 3.19 annotates the number of times each depth is used.

$$\begin{aligned} V &= 42/4 \times \{(3.0+1.8+1.7+2.0+2.6) \\ &+ 2(2.8+2.4+2.2+2.0+2.2+2.3+2.7+ 2.8) \\ &+ 3(2.3) + 4(2.5+2.4)\} \\ &= 10.5x(11.1+2x19.4+3x2.3+4x4.9) \\ &= 10.5 \times (11.1 + 38.8 + 6.9 + 19.6) \\ &= 10.5 \times 76.4 = 802.2 \text{ m}^3. \end{aligned}$$

The formula includes a value $+\Sigma V$, all the extra little bits of volume outside a whole block.

Do they matter?

By inspection block 52, near D/S 134 (Figure 3.19), seems to have the highest $h = 0.5$ in one corner. $V_{52} = (0.5 + 0 + 0 + 0) \times 10.5 = 5 \text{ m}^3$.

V_{55} would be considered a whole block as it's mostly inside the boundary.

$V_{56} =$ Maybe 1.5 m^3 . They would all seem insignificant and total less than 10 m^3 . Does it matter?

3.9.4.1 Block Volume Value

Full block volume, over 56 blocks (Figure 3.19), is calculated to be 2853 m^3 using the methodology illustrated in Section 3.9.4.

3.9.4.2 Pyramid Volume for Batters

What about the volume of the batter slope of 39° , $m = 1.25$ (Figure 3.13)?

Area of a triangle, $a = \frac{1}{2} h^2 m$ (or $\frac{1}{2} h b$)

Volume of a pyramid, $V_p = \frac{1}{3} a h$

So, the batter volume for each batter from the top left, 350E, 7500N, along each wall, could be treated as a **pyramid**. By inspection, at the top corner of block 1 (Figure 3.19), $h = 3$, so the toe, b (width), is, say 4, from crest. Area = $\frac{1}{2} (3 \times 4)$. $a = 6$. This is the base area of the pyramid.

Assuming a straight gradient from crest to toe along grid line

$$\text{Length of 350E grid} = 7500 - 7437 = h = 63. V_{350E} = \frac{1}{3} (6 \times 63) = 126 \text{ m}^3$$

$$\text{Length of 7500N grid} = 350 - 392 = h = 42. V_{7500N} = \frac{1}{3} (6 \times 42) = 84 \text{ m}^3.$$

$$\text{Excavation volume, allowing for gradient batters,} = 2853 - 126 - 84 = 2643 \text{ m}^3$$

How does this gradient line approximation compare with batter volumes calculated from the individual cross sections?

Compare the straight line gradient volume with the volumes related to cross section spot heights.

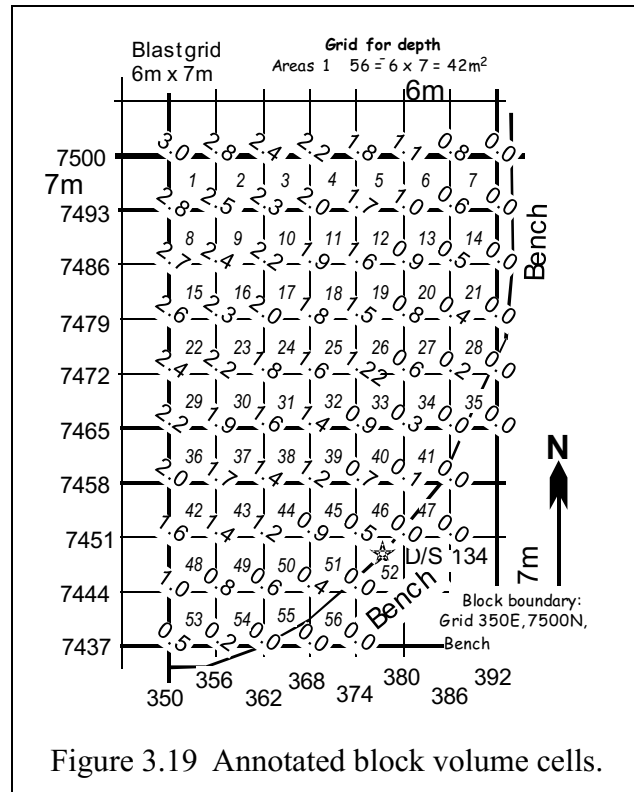

Figure 3.19 Annotated block volume cells.

Figure 3.20 shows the batter volume along the 350E grid from 7500N down to 7437N. This profile volume calculates as 196 m³ compared with the straight gradient value of 126 m³, i.e., 70 m³ more because of the difference between the profile and the straight gradient.

Similarly, Figure 3.21 shows the difference of only 15 m³ along the 7500N grid between 350E and 398E because the profile and gradient are more similar.

The difference in batter volume between the two methods is 85m³. The excavation volume using end areas, accounting for batter ground profile is 2562m³. See Section 3.9.2.3 and Table 3-3.

The volume calculated by block volume and gradient batters is 2643m³ (Section 3.9.4.1). Subtracting a further 85m³ results in an excavation volume of 2558m³, which agrees well with the 2562m³ previously calculated in Section 3.9.2.3

All this data is, of course, reduced in GIS and packages such as Surpac™ etc.

The purpose of the last few pages has been to present a number of methods that can be used for hand calculation of excavation volumes. No heavy maths is needed, just the tedious application of a few basic formulae.

They could also form the basis of small computer programs in MATLAB™ or spreadsheet manipulation in Microsoft Excel™.

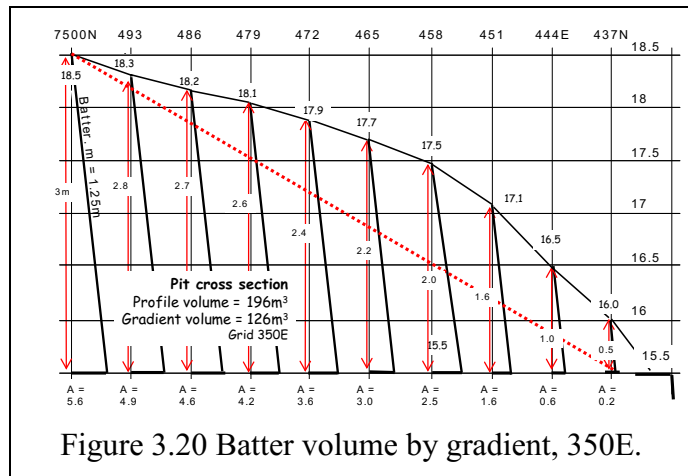

Figure 3.20 Batter volume by gradient, 350E.

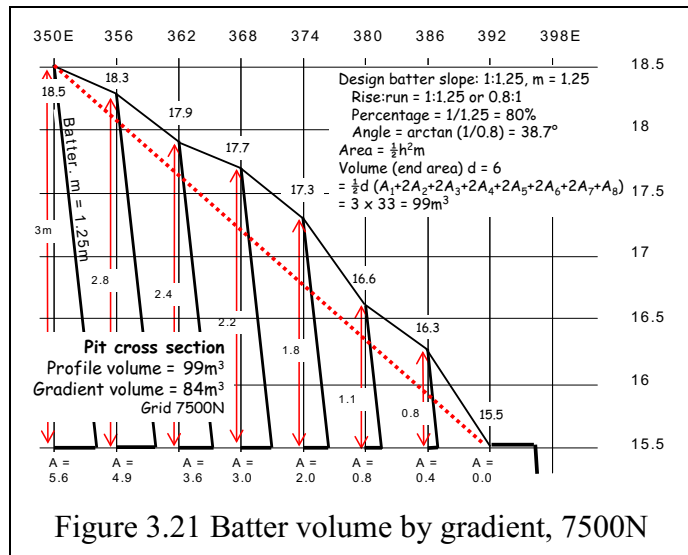

Figure 3.21 Batter volume by gradient, 7500N

3.9.5 Volume by Contour

Another approach to obtaining volume is to calculate the area of each contour formed between the boundary and the contour line. The volume is then calculated by the end area method, the distance being the contour interval.

Previously Figure 3.13 showed grid heights. The grid can now be contoured, a method that can be hand drawn by inspection and estimates of contour line position.

Alternately, contours are calculated and plotted using GIS and mapping programs. They are also a popular source of algorithm development by computer programmers.

Figure 3.22 shows contours generated by calculating contour values at appropriate linear grid intercepts.

Until computerisation of mapping, areas were determined using a mechanical integrator called a **planimeter**.

An approach available to the programmer is to use area by matrix cross multiplication, the coordinate pairs being the E and N grid intercepts used to plot the contours. The area between the boundary and the 18m contour is about 120 m².

Figure 3.25 is a larger image of Figure 3.22 and can be used as an exercise in contour mapping and data extraction as detailed below.

Although hard to pick out, the coordinates for the 18m contour boundary are:

350, 7476; 352, 7479; 356, 7493;
361, 7500; 350, 7500; 350, 7476.

Notice that the figure closes back to the start point at 350, 7476.

Continuing a calculation of contour areas, the following area values were realised:

RL 18.5: 0, RL 18.0: 117, RL 17.5: 490, RL 17.0: 928,
RL 16.5: 1319, RL 16.0: 1758, RL 15.5: 2295.

Volume by end area = $d/2(a_1 + A_n + 2(A_2 + A_3 + \dots + A_{n-1}))$

where **d** is the contour interval of 0.5m

$V = \frac{1}{2} (0.5) \times (0 + 2295 + 2(117 + 490 + 928 + 1319 + 1758)) = 0.25 \times (2295 + 2 \times 4609)$
 $= 0.25 \times (2295 + 9218)$

$V = 0.25 \times 11513 = 2878 \text{m}^3$.

Note relatively good agreement in the volume using the three methods:

batter volumes have been excluded from the calculations.

- End area = 2857, recalculated for no batter.
- Block = 2853, from Section 3.9.4.1.
- Contour = 2878.

3.9.6 Missing Grid Data

Occasionally grid points may be missed, either being unobservable or inadvertently. What does one do?

If the data is missing inside a block of levels it may be best to **interpolate** the missing value. This will involve a judgement of the variation in slope around the data point. Generally, a **linear** interpolation is the best estimate.

Linear interpolation can be used to **calculate** the E and N values of contours on the blast grid.

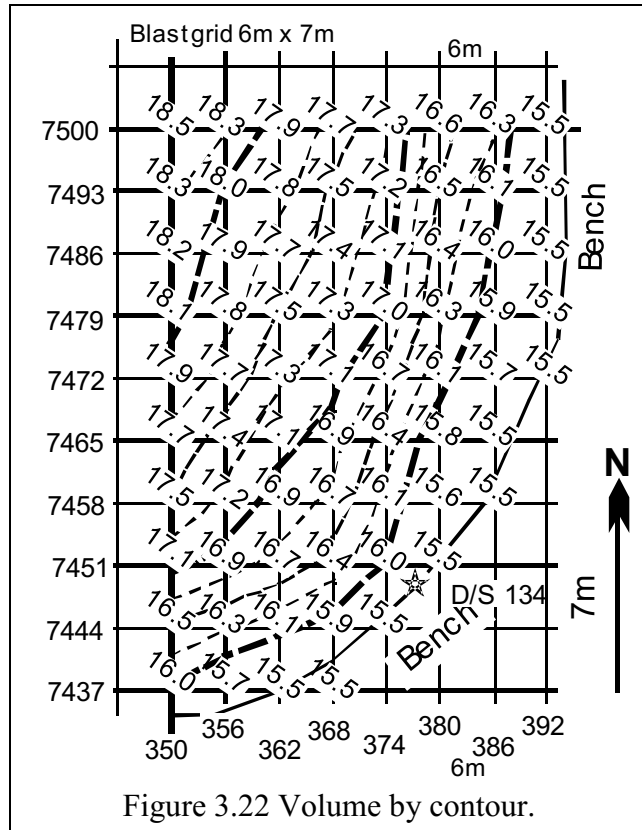

Figure 3.22 Volume by contour.

Say we are missing a level at 356E, 7493N (see Figure 3.23) interpolating on 7493 between 350 and 362 (18.3 – 17.9) - gives 18.05 interpolating on 356 between 7500 and 7483 (18.3 – 17.8) - gives 18.1 interpolating diagonally (18.5 – 17.7) gives 18.1 interpolating diagonally (18.2 – 17.9) gives 18.05.

A value of 18.0 or 18.1 would seem reasonable, and wouldn't make any significant difference to calculations.

Having said that, **bicubic** interpolation is a powerful tool, but is not considered here. To interpolate a point in a square, we need an array of 16 points, and derive slopes, to get a “better” answer. This is probably true for relatively homogeneous data fields, but our simple need doesn't justify it. Surpac and other mining and GIS packages uses this stuff, and a lot more specialised routines such as Lerchs-Grossman algorithm as well, in the generation of ore body estimates.

Similarly, missing data adjacent, but outside, the data field may be determined by **linear extrapolation** of the preceding values.

We are missing a level at 350E, 7500N (Figure 3.24). Extrapolating:

- on 7500 from 362 to 350 (17.9 – 18.3) gives 18.7
- on 350 from 7486 to 7493 (18.2 – 18.3) gives 18.4
- diagonally (17.7 – 18.0) gives 18.3

Meaning the 3 values results in a value of about 18.5

The methods will help **generate** a complete set of grid values from a **few** missed points. Try calculating one of your **missing** grid lines from your practical session. Check your results with data gathered by the other members of your class.

Different? But what difference would it make in the overall scheme of things.

Don't extend your extrapolation beyond your data boundary. Certainly, not more than one grid interval.

The calculated values should not be too far from real (missing) values and should not cause any serious errors in area or volume. Your calculations need to be made from defensible estimates backed up by observed data.

In general, when drawing profiles or plans from measured data, you can only join the points by a **line**. Don't be tempted to “pretty” the drawing up by using curves or splines to make it look “nice”. There is generally less truth in a pretty curve than a straight line as there are no extra artefacts to distort the data.

The area (Figure 3.25) is reproduced here below to allow you to plot a contour over the area. A contour interval of 0.5 m should suffice.

3.9.7 Stockpile Volumes

Angle of repose for free stock piles.

Material for transport is stored in a **stockpile**. Any free standing, free flowing material will exhibit a tendency to form a heap where the slope of the free-standing material is often called the **angle of repose**.

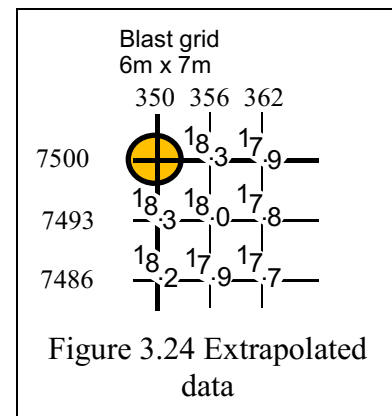
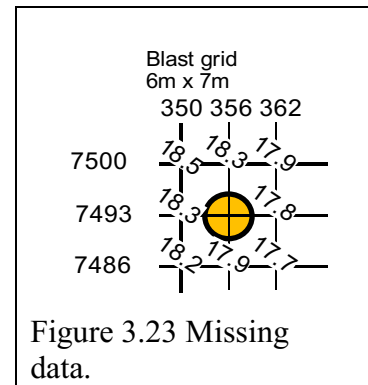

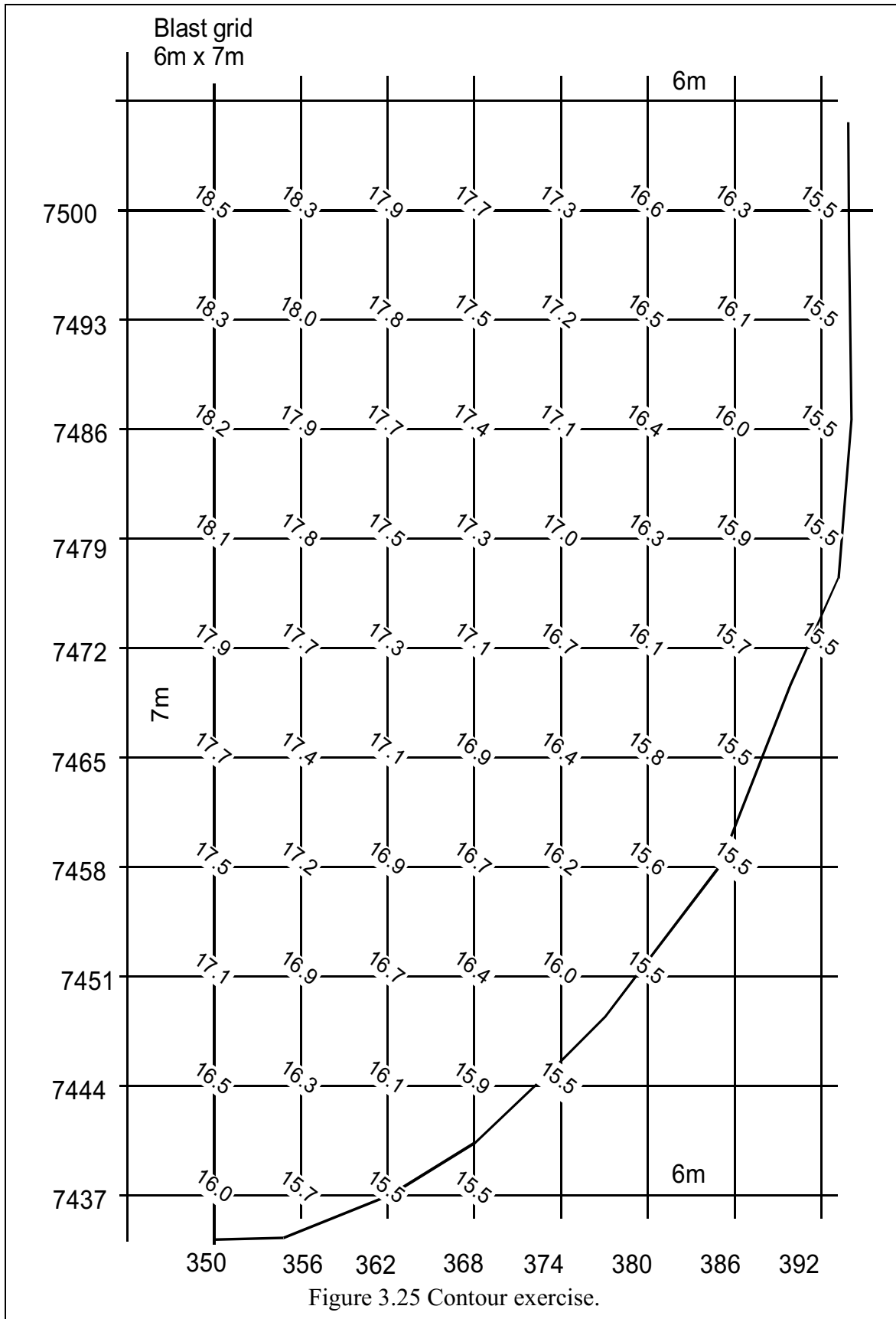

Most free standing mined material seems to stabilise at about:

- 25°, granite and blast furnace slag
- 35°; iron ore, coal, sand and gravel.
- 40°, manganese ore

These angles represent the following slopes (1:m) and percentage slope.

- 40° = 1:1.2, 84%
- 35° = 1:1.4, 70%
- 25° = 1:2.1, 47%

If the height, **h**, and the length of the crest, **ℓ**, of an unrestrained stockpile is known then an approximation of the volume can be arrived at.

The triangular end area cross section = (h x m) x h.
= $h^2 m$. Where m is the slope.

The conic volume $V = \pi r^2 \frac{h}{3}$

The volume is cross sectional area x crest length
+ volume of the cone (half at each end.)

Figure 3.26 shows an iron ore stockpile,

repose angle 35° slope, m, = 1.4

Crest length, ℓ , = 50m; height, h, = 25m,

end area = $h^2 m = 25^2 \times 1.4 = 875m^2$,

Length = 50,

Body volume = $\ell \times A = 50 \times 875 = 43,750 m^3$.

Cone volume, $r = m h = 35$.

$V = 3.14 \times 35^2 \times 25/3 = 32,070m^3$.

Total volume = $75,820 m^3$.

The stockpile is 120m long, 70m wide and 25m high.

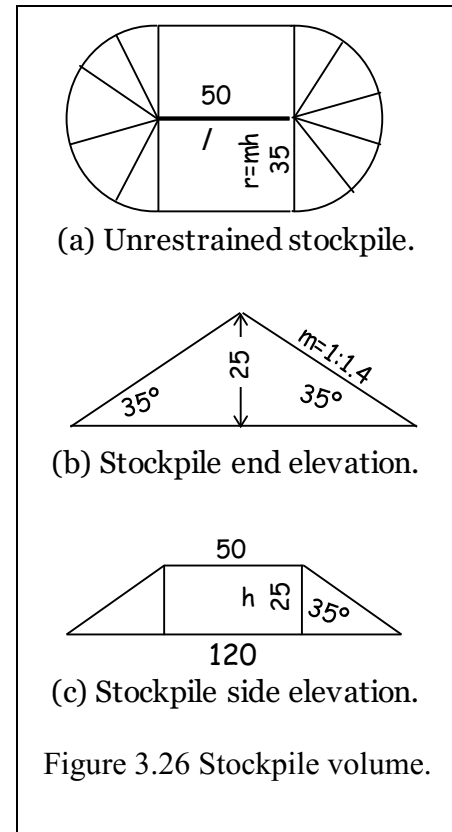

3.10 Concluding Remarks

This chapter has presented you with a direct application of elevations (heights) that were treated in Chapter 2. Using heights, we have seen how profiles of linear features such as roads, sewer and storm water lines could be obtained. This becomes important for civil engineers who have to employ the knowledge of vertical sections (longitudinal and cross sections) to compute earthworks (cuts and fills) during the design of their features. For those in mining, computing volumes of stockpiles in addition to designing Ramps and Berms are daily routines that will call upon the knowledge of computing volumes learnt in this Chapter. For example, in designing a Box Cut at a given dipping gradient, one requires to know how to obtain heights and areas both which lead to the blast volumes to be removed. This chapter has presented several methods that grid the given area upon which the heights are obtained with respect to a given bench. This is surely a chapter that you would like to revisit more often.

3.11 Reference to Chapter 3

1. Irvine and Maclellan (2006) Surveying for Construction. Fifth edition, McGraw, Chaps. 5 and 6
2. Schofield and Breach (2007) Engineering Surveying. Sixth edition, Elsevier, Chap. 3

Chapter 4 Total Station: Measurements and Computations

4.1 Introductory Remarks

This Chapter introduces you to the Total Station instrument used for measuring angles and distances that are needed to generate planar coordinates from the traverse method discussed in the next chapter. Once you have completed this chapter, workshop materials in Appendix A1-3 and the field practical in Appendix A2-3, you should:

- ✓ Be familiar with the Total Station instrument and its parts.
- ✓ Be able to set and operate the instrument.
- ✓ Be able to record (book) angular and distance measurements in a manner that can be understood by other professionals.
- ✓ Understand the errors associated with Total Station operations.

LASER SAFETY: This part is based on:

- (i) Australian Standard 2211-2004 Laser Safety.
- (ii) AS2397-1993 – Guide to the Safe Use of Lasers in the Construction Industry.

Total Stations use a Class 1 or Class 3 laser for distance measurements. The major hazard when using a laser is to the eye, i.e., the retina – associated with lasers in the visible and near infrared spectrum. The lens of the eye will focus the Laser beam onto the retina of the eye causing a microscopic burn or blister to be formed. This can lead to temporary or permanent blindness. **Laser safety rules** include the following operator responsibility:

- ✓ Do not point the laser beam at another person. If the laser beam strikes an eye it could cause serious injury.
- ✓ Do not look directly into a laser beam – it could cause serious eye injury.
- ✓ Do not look at a laser beam through a telescope, binoculars or other optical instruments.
- ✓ Sight targets so that the reflected laser beam does not deviate from the working observation path.

4.2 Instrumentation and Operation

4.2.1 The Total Station

- ✓ Telescope (see Figure 4.1a containing line of sight): 30x or 40x magnification; short so it can be plunged.
- ✓ Graduated glass encoder circles are detected for horizontal and vertical angular displacement.
- ✓ Circle clamps and tangent slow motion screws allow fine rotation to the target once a direction has been clamped.
- ✓ The vertical circle “normal” position is on the left (Face Left, FL) as indicated in Figure 4.1a. Some instruments are marked as Face I.
- ✓ When the scope is plunged, the vertical circle is on the right (Face Right, FR or Face II).
- ✓ An optical plummet in the tribrach or theodolite itself allows precise centring over a point.
- ✓ The circular bubble in the tribrach allows coarse levelling with the tripod legs.
- ✓ The levelling head comprises 3 foot screws used to precisely level the instrument.
- ✓ In electronic instruments, the level bubbles may be internal and only visible on the LCD display.
- ✓ An EDM may be mounted atop the telescope (for older instruments) or be inside the instrument and measure on the collimation axis (in modern instruments).
- ✓ Electronic data recording devices may be externally connected or inside the instrument.

- ✓ Important relations between axes (see Figure 4.1 b, c, and d):
 - The horizontal or trunnion axis must be orthogonal to the vertical axis,
 - The collimation axis must be orthogonal to the Trunnion axis,
 - The standing or vertical axis must be orthogonal to the plane containing the horizontal circle,
 - The collimation axis must intersect the trunnion axis.

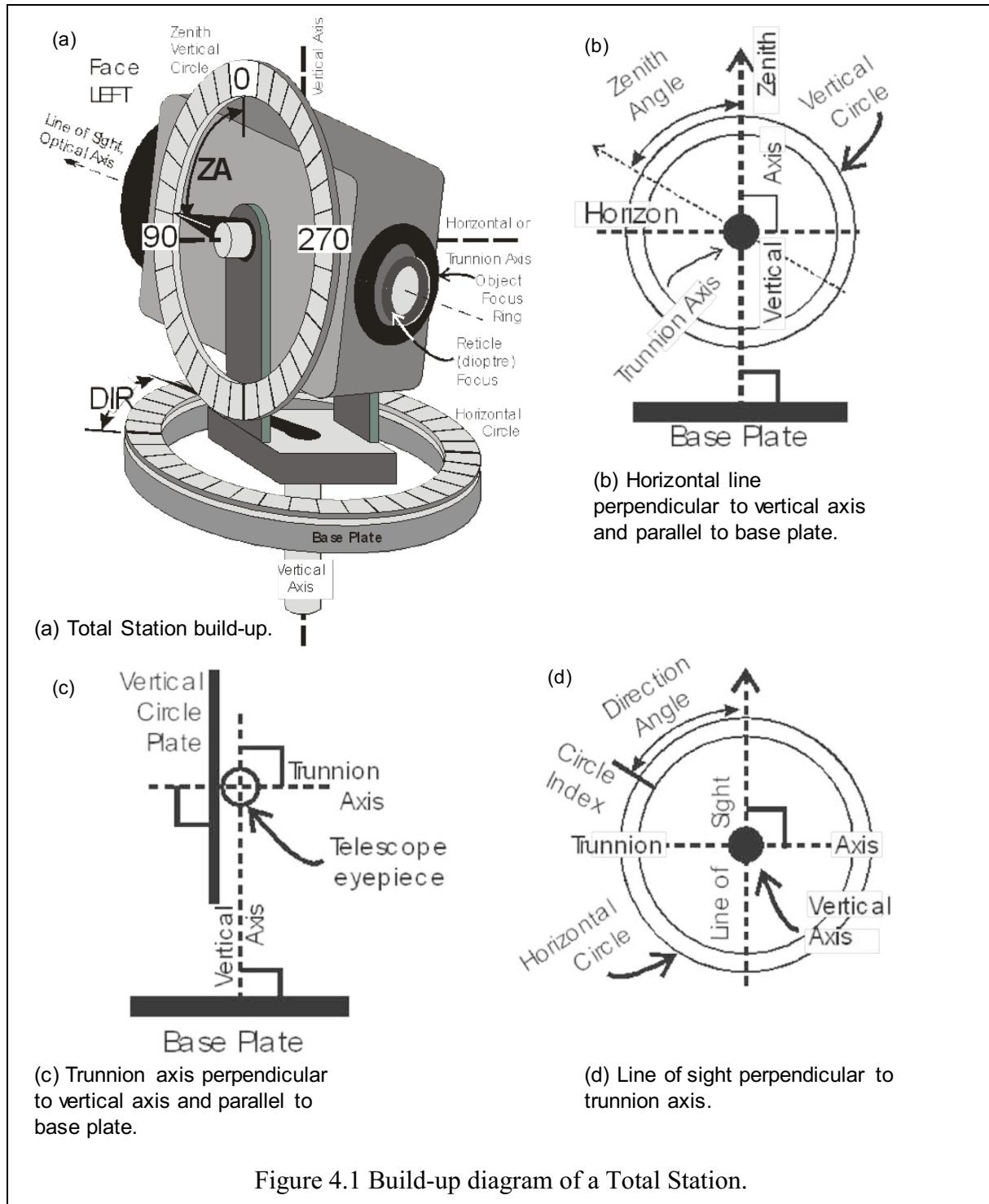

4.2.2 Setting over a Point Using the Optical or Laser Plummet

Centring accurately over a control point helps eliminate large random errors in your observations. This applies to Total Stations, levels, prism sets, laser scanners and GNSS receivers. The method outlined below does not require the use of a plumb bob, however one must be able to place the head of the tripod fairly over the point to start with.

1. Extend the tripod legs to a mid-chest height and clamp legs.
2. Stand over the point and project one leg about a step in front of yourself, keeping the tripod head roughly horizontal, make a short step backwards and project the legs equidistantly so that the tripod is set as an equilateral triangle roughly over the point with the head level. Set the tripod feet firmly in the ground surface.
3. Ensure that the tripod clamps are secure. Mount the instrument on the tripod, in the centre of the tripod head, and check that the plate clamp bolt is secure. Ensure the foot-screws are in the centre of the run.
4. Look through the optical plummet or turn on the laser plummet. You should be able to see the control point in the plummet eyepiece or illuminated by a red laser dot. Ensure that the reticule is in sharp focus and focused on the ground or point.
5. Using the foot-screws, drive the reticule or laser until it is over the point. The tribrach and the plate will not be parallel to the tripod head. The circular level may be well off centre.
6. By adjusting the length of each tripod leg, centre the circular level using the legs only. The reticule should stay fairly well centred over the point.
7. Once the plate circular level is reasonably centred, use the foot screws to centre the plate level bubble. The Trimble M3 uses an electronic level display to provide levelling guidance. Refer to Section 2.4.2 on levelling with the foot-screws. Check plate level through 90° .
8. Check the optical plummet. The reticule or pointer will have moved off the point. Loosen the plate bolt slightly and move the instrument and tribrach across the tripod head to re-centre the plummet. Do not “twist” the tribrach around its axis during re-centring.
9. Check and re-centre the plate level using the footscrews, check centring through the optical plummet, check focus and parallax, check plate level through 90° .
This is an iterative process.
10. Check centring over the point by observing the optical plummet through 4 quadrants. Any collimation error will show as the reticule path describes a small circle around the point. Slight collimation can be eliminated by centring the point inside the described reticule circle.

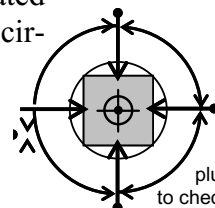
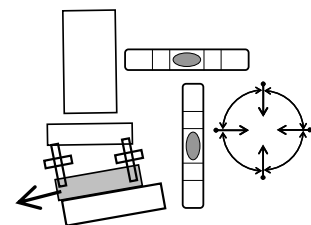
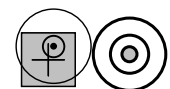
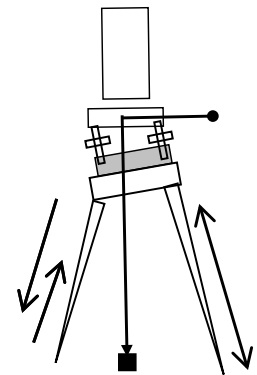
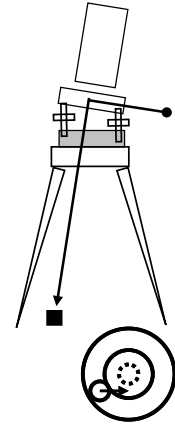

Rotate plummet 90° to check centring

The commonality of Sokkia TS and prism sets allows the semi-forced centring technique to be used

in traversing control points. The system allows swapping the instrument and prism sets between tribrachs without having to re-centre over the point or re-measure heights. Any re-levelling is insignificant.

4.2.3 Preparing Trimble M3 DR 5" for Survey Observations

The Trimble M3 DR 5" Total Station, or similar, is used in some tertiary institution's Surveying courses and is typical of most surveying modern instruments. The setup, control and output of survey information is displayed on a 90 mm QVGA colour touch screen. The operating system is Windows® Embedded CE 6.0. The system displays and programs are run by software such as Trimble Field Access, which allows common survey tasks to be carried out. The software stores data, provides special survey job solutions; it includes the COGO program to solve most complex trigonometric problems.

The operation of the M3, help files etc., are accessed via:

<http://www.trimble.com/Survey/trimblem3.aspx?tab=Overview>

and are recommended for your introduction to the instrument.

Trimble M3 DR 1D Users Manual can be access via:

trl.trimble.com/docushare/dsweb/Get/Document-267977/TrimbleM3_DR_1D.pdf.

Trimble M3 data sheet:

trl.trimble.com/docushare/dsweb/Get/Document-262358/022543-155J_TrimbleM3_DS_0414_LR.pdf

Trimble Digital Fieldbook V7.01:

trl.trimble.com/docushare/dsweb/Get/Document-517810/TDFv701_Help_English.pdf



4.2.4 Preparing Sokkia SET530RK3 for Survey Observations

The Sokkia SET530RK3 Total Station used in teaching civil and mine engineering surveying units at Curtin University (Australia) is typical of most surveying instruments. It is controlled via 2 keypads and screens. The measured data can be read off either screen. The instrument has a number of built-in functions for:

- setting instrument parameters,
- solving particular repetitive computational tasks,
- recording observational data

For the particular field exercises in civil and mine engineering units, we recommend that **all observational data** be recorded in a field survey book to provide students with booking practise. The complexity and expertise needed for data recording, download and manipulations precludes the use of many of the instrument's features.

Do not record the H distance from the SHV screen. The instrument MAY have a scale factor (SF) embedded in a JOB. The SF affects the horizontal distance (H) only.

4.2.4.1 Preparing the Instrument for Observations.

After levelling and positioning the instrument over its designated point, insert a charged battery and turn the instrument on. Allow time for the display to boot. It should normally boot to page 1 of the measurement screen.

The screen shows the instrument is in **measure mode** (Figure 4.2) **(Meas)**
 the prism constant **PC -30**
 is set for the normal target
 atmospheric correction is zero **ppm 0**
 last slope distance: **S 55.450m**
 current vertical angle: **ZA 95° 34' 32"**
 current direction: **HAR 195° 37' 45"**

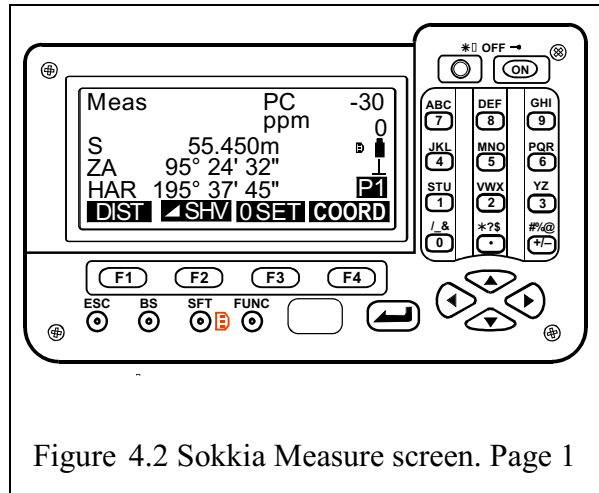

Figure 4.2 Sokkia Measure screen. Page 1

the current display page is **page 1**
 the highlighted menu labels are controlled by the function key (**[F1] – [F4]**)

[F1] initiates a **distance measurement** to the target
 the distance stays on the screen until **F1** is used for the next distance measure.

The **ZA** and **HAR** readings vary as the telescope is moved.

[F2] toggles between the vector screen
 slope distance S, VA and HAR and the rectangular screen, **SHV** (Figure 4.3)
 slope S, horizontal **H** and vertical **V** distance

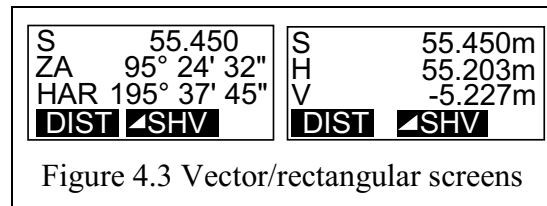

Figure 4.3 Vector/rectangular screens

These rectangular coordinates refer to the measurement at the last **[F1]** press.

The **FUNC** button toggles through the three (3) pages of the **Meas** screen (Figure 4.4).

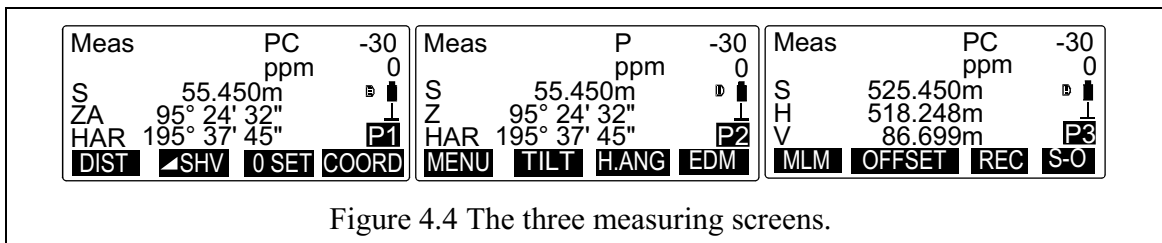

Figure 4.4 The three measuring screens.

The **MENU** screen is accessed through the **[F1]** function key of the **Meas** screen **P2**. It allows memory and instrument configuration to be set (Figure 4.5).

Return to the **Meas** screen by using **[F1]** function key.

Function key **[F2] TILT** activates a graphics screen to allow accurate instrument levelling, or to allow a levelling check.

Return to the **P2 Meas** screen using the **ESC** button.



If **Out of range** is displayed on the **Meas** screen, then the instrument is out of level and the tilt compensator cannot provide corrections. Check and re-level the instrument using the plate bubble or the **TILT** screen (Figure 4.6).

4.2.4.2 Setting the Horizontal Angle Reading.

Function key **[F3] H.ANG** on **P2** allows Horizontal Angle Reading (HAR) input when aligning with a target of known bearing (Figure 4.7). It requires bearing to be input in the **D.MMSS** format, followed by the ENTER key. 

195° 37' 45" is input from the keypad as:

195.3745 

Note that on the **P1 Meas** screen the function key **[F3] OSET** allows a direction of **0° 00' 00"** to be set. After the first **[F3]** key press the **OSET** flashes. Press the **[F3]** key a second time to confirm the setting. The display is a bit slow in updating.

Function key **[F4] EDM** displays two pages of information (Figure 4.8):

The first page allows setting of the “distance measuring mode”, the method by which the slope distance is determined.



Fine “r” is the default setting, a repeat measure to a prism, displays to 0.001m,
precision $\pm(3\text{mm} + \text{dist.} \times 2\text{ppm})$

Fine “AVG” for more precise distance, averages over 3 – 9 readings, displays to 0.0001m,
precision $\pm(2\text{mm} + \text{dist.} \times 2\text{ppm})$

Fine “s”, Rapid “s” are single measures. They are slightly faster measurements, but of less accuracy,
displays to 0.001m.

The second page, Figure 4.9, accessed by the down button  allows input of current atmospheric conditions to compensate for deviation from the instrument’s default atmospheric condition of zero ppm correction, **ppm 0**.

[F1] 0ppm allows the reset of default condition.

Changes to these screens must be confirmed using the enter  before exiting the **EDM** screen using the **ESC** button.  You are returned to the **P2 MEAS** screen.

EDM atmospheric correction is discussed in Section 4.3.1. Standard atmosphere for the Sokkia SET530 is: Pressure 1013hPa, temperature 15°C, relative humidity (RH) 0%. Due to the small contribution that humidity makes to most measurements, it can be ignored. The SET530 is capable of measuring to 4000m on a single prism, but even at Newman, with an approaching cyclone and RH = 75% the error only equates to 1ppm (0.004m) by ignoring RH correction.

EDM also allows input for non-standard prism constants. These constants arise when target prisms such as 360° degree prisms and 360° degree mini-prisms are used. The normal Sokkia APS12-MAR target set using an AP01AR 62mm

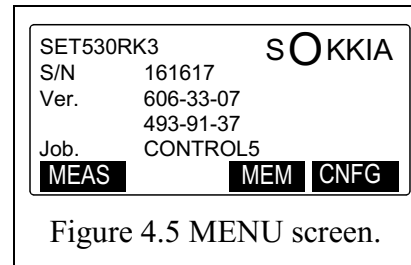

Figure 4.5 MENU screen.

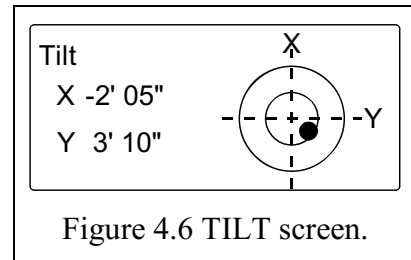

Figure 4.6 TILT screen.

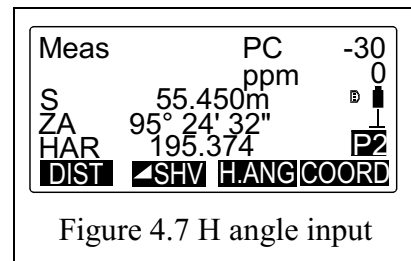

Figure 4.7 H angle input

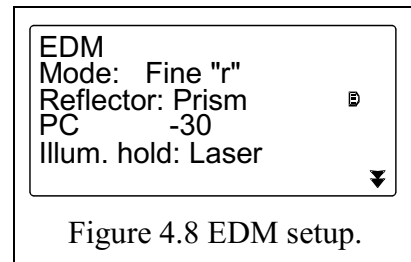

Figure 4.8 EDM setup.

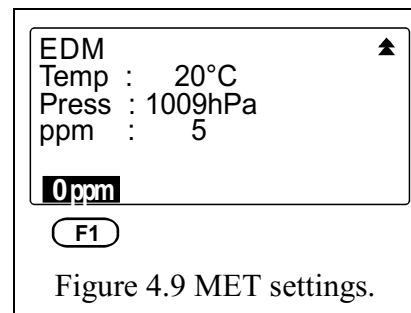



Figure 4.9 MET settings.

diameter prism has a prism constant of -30 mm. This is shown on the screen as **PC - 30**. The distance measured through this prism is 30 mm too long because of the length of mechanical construction of the target, the reflected beam in the prism and the change of light velocity through the prism glass. This extra length is subtracted by the on-board controller. Most circular 62mm and “peanut” prisms have a PC -30 . The PC is marked on the prism, must be set on the instrument and recorded in the field book.

Prominent exceptions are the Leica Geosystems GPR121/111, GPH1P Circular prisms with a PC of -34.4 . (4.4mm different from most others). If you work with Leica Total Stations use only their prism sets and be very mindful of the use of Additive Prism Constants (APC) for their various prism types. Table 4.1 summarises various APCs.

The **SFT** button toggles through the prism types available in the EDM menu while in the **Meas** screen (Figure 4.10),

circular prism, **PC -30** (or as defined in setup) **SFT**
 flat reflector sheet, **PC 0** and 
 reflectorless, **PC 0**.

The 360° Mini-prism, used in Field Practical 3 (see Appendix A2-3), has a **PC +3**. The circular prism, **PC -30**, can be used and a correction of 0.027 (27 mm) is applied to calculations of the recorded field slope distance data. This method may eliminate the need to set-up a new PC value in the Total Station.

ESC button escapes the current operation,

BS button activates Back Sight menu screen.

use **H.ANG** function on the **P2 Meas** screen to input orientation for this exercise.

FUNC button toggles the **Meas** screen.

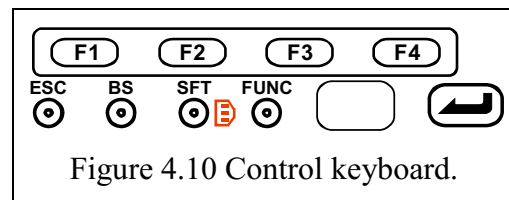

Figure 4.10 Control keyboard.

The square red plastic window is used by a remote controller handset.

4.2.4.3 Setting Initial Direction using a Tubular (Trough) Compass

The Sokkia Total Stations are equipped with a tubular compass that is attached to a slot in the instrument carrying handle. The CP7/CP8 compass allows setting the instrument to the local magnetic north direction. The compass comprises a tube containing a compass needle, needle pivot and a clamping screw. A properly balanced free needle lies horizontally aligned in the magnetic field.

A pointer on the south end of the needle is viewed through a window and aligned between two index lines, the lubber lines. Attached to the handle of the set-up TS, the instrument is turned towards North until the south end of the needle swings freely and stabilises between the lubber lines. Clamped, and using the slow-motion screws, the TS is aligned to 360° MAGNETIC. (Aligned with the magnetic meridian.)

Adding the magnetic declination of the place to 360° results in the TRUE meridian direction of the pointing. Appendix A2-3 and Field Practical 3 demonstrate the use of the compass for azimuth setting.

True direction (T) = Magnetic (M) + deviation (D).

Setting magnetic North, $M = 360^\circ$, where, in Perth deviation is about $-1^\circ 35'$, $T = 358^\circ 25'$.

Canberra's deviation is $+12^\circ 20'$. $T = 12^\circ 20'$. Clamped on magnetic north, the TRUE direction is entered using the **[F3] H.ANG** function and thus sets the alignment of the TS closely with the geographic meridian. (True North).



Figure 4.11 Tubular compass.

The compass needle must be balanced against the magnetic inclination of the area. Perth's inclination is -66° . A compass balanced in Japan (inclination $+49^\circ$) must be re-balanced by an instrument technician. (Needle removed from its housing. Balanced on a vertical pin in the pivot by moving a small copper coil on the needle until the needle is horizontal).

4.3 Measurements

4.3.1 Distance Measurements

Distance is a linear measurement of length and can either be vertical, horizontal or slope (slant). It can be measured either directly (e.g., using a measuring tape, chaining, and pacing) or indirectly using e.g., an electronic distance measurement (EDM) device fitted in the Total Station. Indirect distance measuring can take on the form of geometrical (e.g., optical) or electronic (e.g., wave based). Distances find use as follows:

- Horizontal and Vertical Distances
 - ✓ Mapping
 - ✓ Control surveys
 - ✓ Engineering design works
- Slopes and Vertical Distances
 - ✓ Setting out construction sites
 - ✓ Vertical distances are useful in height transfer from floor to floor in multistorey building and in mining (surface to underground)

EDM is the most common method of distance measurement nowadays and exists in Total Stations, hand-held distance meters (Disto) and laser scanners. They can be classified according to:

- ✓ Radiation source: optical (visible and NIR) or microwave
- ✓ Measurement principle: phase difference or pulse
- ✓ Whether a reflector is required or not (reflector-less)

Phase difference method (Figure 4.12) is the most common (at the moment) method of distance measurement found in surveying instruments. In Figure 4.12, the

- emitted signal $y = A \sin(\omega_m t)$ $y = A \sin(\omega_m t)$,
- received signal $y = A \sin(\omega_m t - \phi)$ $y = A \sin(\omega_m t - \phi)$.

Note that ω_m denotes the angular frequency of the modulating wavelength. The EDM instrument measures the phase difference between the emitted and received signals, $\Delta\phi$. The known modulating wavelength, λ_m , can be used to convert the phase difference into the elapsed time between emission and reception. Only fractions of one complete cycle (wavelength) can be measured, thus, there remains an unknown integer number of cycles (the ambiguity), n , between the instrument and reflector. The two-way flight time (time between emission and reception), Δt , is given by:

$$\Delta t = \left(\frac{\Delta\phi}{2\pi} + n \right) \frac{\lambda_m}{v}$$

- The distance is derived by multiplying the time difference by the velocity. However, since Δt represents the round-trip (i.e. two-way flight) time, it must be divided by 2 to obtain the distance between instrument and reflector,

$$d = \frac{c\Delta t}{2}$$

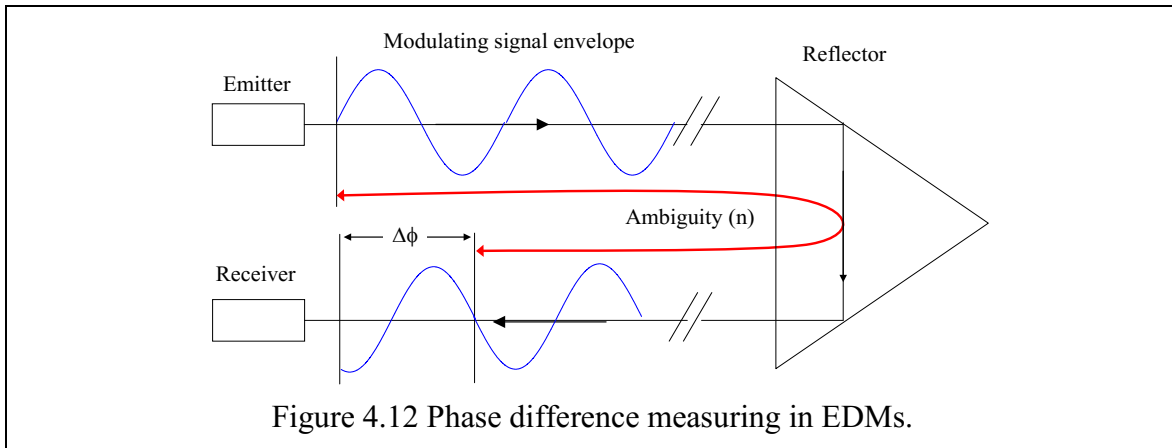

Pulse method (Figure 4.13) is becoming more common in EDMs, particularly reflector-less instruments. Instead of continuous amplitude modulation, the carrier signal (visible or NIR light) is modulated into discrete pulses. The distance is derived from the two-way flight time of the pulse

$$2d = v(t_r - t_e), \quad \therefore d = \frac{v(t_r - t_e)}{2} = d = \frac{c\Delta t}{2}.$$

Since $c \approx 300 \text{ mm/ns}$, 10 mm range resolution requires 67 pulse time interval measurement resolution.

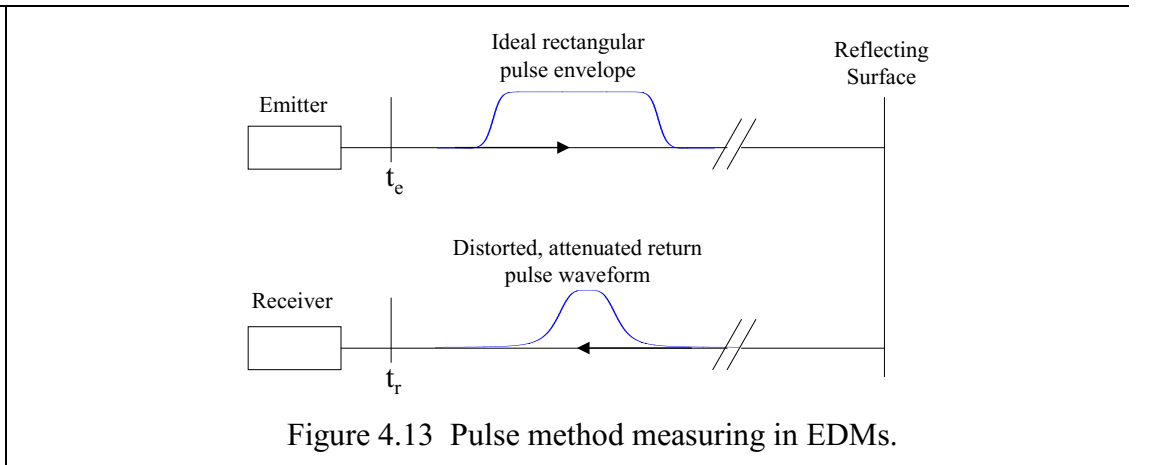

Reflector-less EDM: Many new Total Stations offer two means of EDM

- ✓ Phase-difference based, using a prism
- ✓ Reflector-less, using a pulsed laser

Laser scanners (terrestrial and airborne) are reflector-less. Laser scanner systems featuring the phase-difference method and the pulse method exist. One terrestrial laser scanner actually features both.

Prisms: Prisms used for EDM are glass corner cubes that reflect the incident electromagnetic (EM) radiation back to the instrument.

- ✓ This is because the apex angle of the cube is 90° .
- ✓ Multiple prism clusters are used for long distances.
- ✓ Omni-directional prisms are useful for topographic surveys.

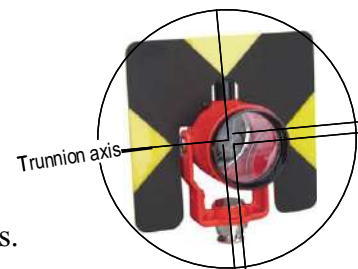

4.4 Prism Constant, Why All the Fuss?

4.4.1 How a Prism is Measured, and its PC is Determined

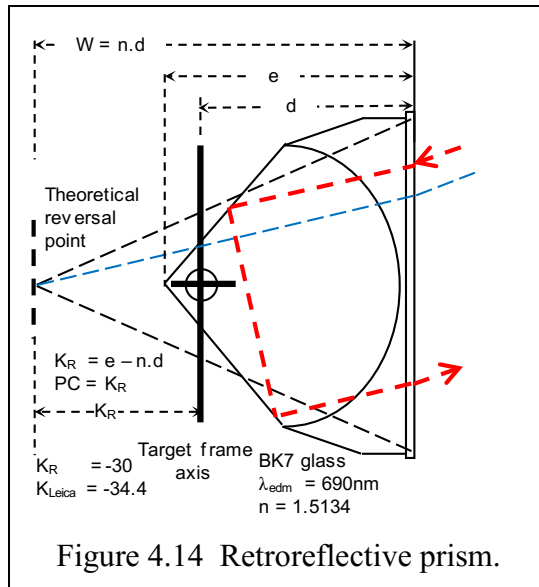

Figure 4.14 Retroreflective prism.

Distance is measured using a modulated light beam reflected back to the instrument by a **corner prism**. The corner prism is used to ensure that the reflected beam is parallel to the incoming measuring beam. It is reflected off the internal faces of the cube.

The velocity of the signal through the prism is retarded by a factor known as the **refractive index** of the glass. It is dependent on the composition of the glass and on the wavelength, λ , of the signal.

BK7 is a borosilicate fused glass with excellent characteristics for prisms. It has high transmissivity, typically over 95% from far infrared (2,000nm) through the visible spectrum (red, 700nm – violet, 380nm) to the near ultraviolet (350nm).

Refractive index, n_d , ranges from 1.513 at 700nm to 1.536 at 365nm. The n_d curve is flatter at the red end of the visible spectrum, allowing the use of red lasers for EDM. The Abbe number, $V_d = 65$, is a measure of low dispersion.

The optical path length of the light within the prism in each case in Figure 4.15 is $(2a + 2b)$, which is equivalent in both cases to twice the base-apex distance, d , since $b=b'$.

Since the index of refraction (n) of the glass is higher than that of air (≈ 1.52), the measured distance is longer. Why?

The base-apex distance d (Figure 4.15) can be determined from the vacuum-equivalent flight time of the signal in the glass, Δt^* , as:

$$d = \frac{c\Delta t^*}{2n_g},$$

which can be rearranged as:

$$\Delta t^* = \frac{2n_g d}{c}$$

For the same flight time in air, which is assumed by the instrument, the biased base-apex distance, d^* , is given by:

$$d^* = \frac{c\Delta t^*}{2n_a} = \frac{c}{2n_a} \cdot \frac{2n_g d}{c} = \frac{n_g}{n_a} d.$$

Assuming the index of refraction of air is 1, then the zero of the prism, i.e., the plane to which the distance measurement refers (the air-equivalent path) is given by $(n_g \cdot d)$. Furthermore, the apex of the prism may be offset from the vertical axis of the target or pole upon which it is mounted. These offsets represent systematic errors that must be modelled and applied as corrections to the measured distances. A measured distance is corrected as follows

- ✓ Subtract the air-equivalent path distance $(n_g \cdot d)$ to reduce the distance to the face of the prism – referred to as the Additive Constant – AC (see Figure 4.16)
- ✓ Add the offset from the prism face to the vertical axis, b .

Thus, the absolute prism constant is given by (Figure 4.16) as

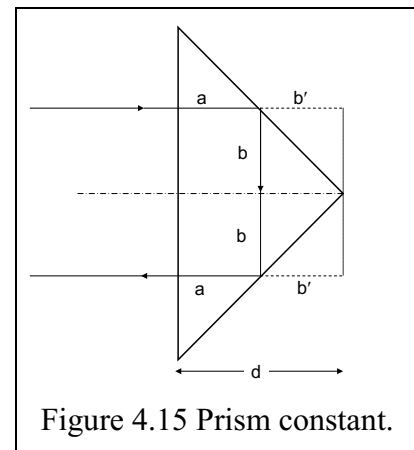

Figure 4.15 Prism constant.

$$PC = -nd_g + b$$

In practice, the combined effect (i.e. prism constant) is determined (through calibration) and entered into the Total Station instrument rather than determining the individual components. Prism-EDM combinations are calibrated together since the estimated prism constant will also contain a component due to the offset of the EDM zero reference from the Total Station vertical axis.

Examples: Typical 62mm diameter prism (Figure 4.16).

Mechanically BK7 is a good glass. It also has a very low level of bubbles and inclusions, is acid resistant and has low water absorption. Its relatively low melting point and annealing temperatures make it relatively inexpensive.

But one has to pay for the precision of the machining of the 90° prism corners.

It can be seen that the ray of light is reflected off the theoretical reversal point, a path about 1.5 times the depth of the prism, and the target frame axis depends on the design **prism constant**, K_r .

A typical 62mm prism has a depth of 47.5mm. The Sokkia EDM has a wavelength of 690nm. With $n_d = 1.5134$, $W = 71.9$ mm and prism constant, $K_r = -30$, the plumb axis of the prism is $71.9 - 30 = 41.9$ mm behind the face of the prism.

Most prism set manufacturers provide a $PC = -30$.

Be aware that the Leica Geosystems standard round 62mm prisms, the GPR series, have a $PC = -34.4$ mm. This value shows on the EDM setting screen as CIRC 0. It is handled internally in the EDM software to display the correct distance.

There are a number of other prism sets available and the EDM **PC** setting in the Total Station has to be set for the prism. The **PC**, or K_r , depends on the mechanical construction of the prism.

Peanut prisms of about 25mm diameter use manufacturer specific carriers to provide a $PC = -20$ or a $PC = 0$, allowing measurements to a corner or restricted face.

360° prisms have **PCs** depending on the physical size of the 6 prism cluster. Two different 360° prisms used at Curtin are:

Bear 360 mini-prism, $PC = +3$ mm, used in field exercises, and

Bear 360 large prism, $PC = +13$ mm

Reflectorless observations, or observations to target sheets, use a $PC = 0$.

For all instruments other than Leica Geosystem products, use the **PC** specified for the particular prism and set this in the EDM **PC**.

4.4.2 The Leica Geosystems Total Station Prism Constant Conundrum

Leica instruments have a strong presence in the mining industry, and in general surveying. If you are using Leica equipment, then use Leica targets and enter the correct constant in the EDM.

If you are using a non-Leica prism then DEFINE or set USER according to the following:

Leica USER $PC = \text{Prism offset (Kr or PC, generally negative)} + 34.4$

$PC = -30$ USER $PC = -30 + 34.4 = +4.4$

$PC = -40$ USER $PC = -40 + 34.4 = -5.6$.

Source: Leica FAQ – Prism Offsets. May 2002.

Finding the **PC** for a Leica defined prism: $PC = \text{Leica constant} - 34.4$.

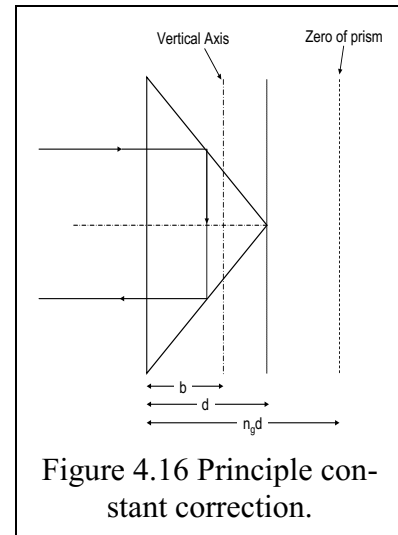

Figure 4.16 Principle constant correction.

Table 4-1 presents:

- the Leica prism, the constant defined in the EDM software and the corresponding PC for other EDMs because the prism is defined, there is no need to provide a USER PC to the instrument
- other prisms. Set the Leica EDM to 0 (circular, GPR series). Then set Leica USER PC as tabled.

Note that reflective tape, PC = 0, can be set in the Leica EDM with constant +34.4 or with constant 0.0 and the Leica USER PC as +34.4.

Leica Prism	Leica constant	Other EDM PC	Leica USER PC
GPR121 (62mm)	0.0	-34.4	
GMP101 (mini prism)	+17.5	-16.9	
Reflective tape	+34.4	0.0	
GRZ4/GRZ122 (360° prism)	+23.1	-11.3	
GRZ101 (360° mini prism)	+30.0	-4.4	
Other prisms	Set Leica constant	Other EDM PC	Set Leica USER PC
62mm circular (PC -30)	0.0	-30	+4.4
62mm circular (PC -40)	0.0	-40	-5.6
Bear 360° mini prism	0.0	+3	+37.4
Bear 360° large prism	0.0	+13	+47.4
Reflective tape	0.0	0	+34.4

Be sure you KNOW how to set the correct PC in YOUR EDM.

As a precaution, always book the prism used, its PC and the PC you set in the EDM menu. And check it during your observations.

Prism Constant Calibration:

- ✓ A simple method for checking or determining the prism constant involves measurement of three distances between points set out on a long line
- ✓ For each distance the following equation can be written $AC = AB + BC$.

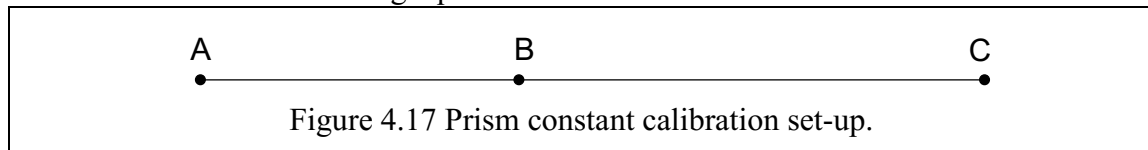

- ✓ From the condition that $AC = AB + BC$, the prism constant, PC, is determined as

$$AB = AB^{OBS} + PC, \quad BC = BC^{OBS} + PC, \quad AC = AC^{OBS} + PC$$

$$AB + BC = AC$$

$$AB^{OBS} + PC + BC^{OBS} + PC = AC^{OBS} + PC$$

$$\therefore PC = AC^{OBS} - AB^{OBS} - BC^{OBS}$$

Scale Error: Perhaps the second-most important instrumental systematic error (particularly in phase-difference instruments) is the scale error. The time-of-flight equation for the phase-difference method can be recast in terms of modulating frequency, f_m

$$\Delta t = \left(\frac{\Delta\phi}{2\pi} + n \right) \frac{\lambda_m}{v} = \left(\frac{\Delta\phi}{2\pi} + n \right) \frac{1}{f_m}$$

- ✓ Scale (i.e. distance-dependent) errors can exist due to errors in the modulating frequency caused by the oscillator – usually expressed as parts per million (ppm = 10^{-6} or 1E-6).
- ✓ In calibrating the scale error, care must be taken to properly model and remove atmospheric effects (particularly temperature), which have a similar systematic effect on distances.

Atmospheric Effects: Temperature, t , pressure, p , and humidity (partial pressure of water vapour, e), affect the index of refraction of air, which is calculated by

$$(n_a - 1) \times 10^6 = \frac{273.15 n_g p}{(273.15 + t) \times 1013.25} - \frac{11.27 e}{(273.15 + t)},$$

$$N_g = (n_g - 1) \times 10^6 = 287.6155 + \frac{4.88660}{\lambda^2} + \frac{0.06800}{\lambda^4},$$

where N_g is the group refractive index and λ is the carrier wavelength. The effects are

- Temperature (largest): 1 ppm per °C (1 ppm is 1 mm at a distance of 1km).
- Pressure: 0.3 ppm per hPa.
- Partial pressure of water vapour: 0.04 ppm per hPa.
- Atmospheric variations in Temperature (t), Pressure (p) and Humidity (e) - result in variations in refraction.

Example: Sokkia Set 530RK3 Atmospheric Correction Factor

The distance correction is $D = d + dC$, where C in ppm is given by

$$C = 282.59 - \frac{0.2942 p}{1 + 0.3661 t} + \frac{0.0416 e}{1 + 0.3661 t} \text{ where}$$

$$e = h \frac{E}{100} \text{ and } E = 6.11 \times 10^{\left(\frac{7.5t}{t+273.3} \right)}, \text{ and}$$

t – Air Temperature in degrees Celsius (C°).

p – Absolute air pressure in Hectopascals (hPa) (actual pressure at observation site).

e – Water vapour pressure (hPa).

h – Relative humidity, RH, (%).

E – Saturated water pressure.

Consider: $t = 35^\circ\text{C}$, $d = 1234.660$, and pressure, $p = 975\text{hPa}$. Correction due to humidity is small and can be ignored.

$$C = 282.59 - \frac{0.2942 \times 975}{1 + 0.3661 \times 35} + \text{ignore humidity}$$

$$C = 282.59 - 254.265. \quad C = 28.3 \text{ ppm}$$

$$D = 1234.660 + (1234.66 \times 28.3 \times 10^{-6}) = 1234.660 + 0.034$$

$$D = 1234.694$$

Next, let us consider $t = 15^\circ\text{C}$, $d = 1234.660$, and pressure = 1020hPa. Correction due to humidity can be ignored.

$$C = 282.59 - \frac{0.2942 \times 1020}{1 + 0.3661 \times 15} + \text{ignore humidity}$$

$$C = 282.59 - 254.463. \quad C = -1.9 \text{ ppm}$$

$$D = 1234.660 + (1234.66 \times -1.9 \times 10^{-6}) = 1234.660 - 0.002$$

$$D = 1234.658$$

Periodic (Cyclic) Errors

- ✓ These exist due to electrical or optical cross-talk (interference) within the EDM instrument.
- ✓ They are on the order of a few mm and behave as sinusoids with wavelength equal to the unit length, which for most EDMs is 10 m.
- ✓ They can have both sine and cosine components.

Summary of Major Error Sources

- Systematic
 - ✓ Instrumental
 - Prism constant
 - Scale
 - Cyclic
 - ✓ Natural: index of refraction
- Random
 - ✓ EDM precision (measure of random error dispersion) is typically specified in the format of $\pm(a \text{ mm} + b \text{ ppm})$
 - ✓ There is a constant part and a distance-dependent part
 - ✓ Example: $\pm(2 \text{ mm} + 2 \text{ ppm})$

4.5 Angular Measurements

Surveyors in Australia, as in many Commonwealth countries, use the sexagesimals system for measuring and reporting angles.

- ✓ There are 360° in one circle
- ✓ Each degree is divided into 60 minutes (arcminutes), $1^\circ = 60'$
- ✓ Each minute is divided into 60 seconds (arcseconds), $1' = 60''$

We are interested in how these angles are measured:

- ✓ The Total Station is levelled so that horizontal angles or directions are measured in a horizontal plane (see Fig. 4.1 (a)).
- ✓ Zenith angles (see Fig. 4.1(b)) are referenced to the zenith, which for a levelled instrument coincides with the local gravity vector.
- ✓ Elevation angles referenced to the horizontal plane.
- ✓ If the instrument is not properly levelled or not in correct adjustment, systematic errors will exist in the angles.
- ✓ These errors will propagate into subsequently computed co-ordinates.

To measure an angle, let us consider Figure 4.18. We are interested in measuring the angle between Stn 1 and Stn 3 with the instrument set at Stn 2. Once the instrument has been set and

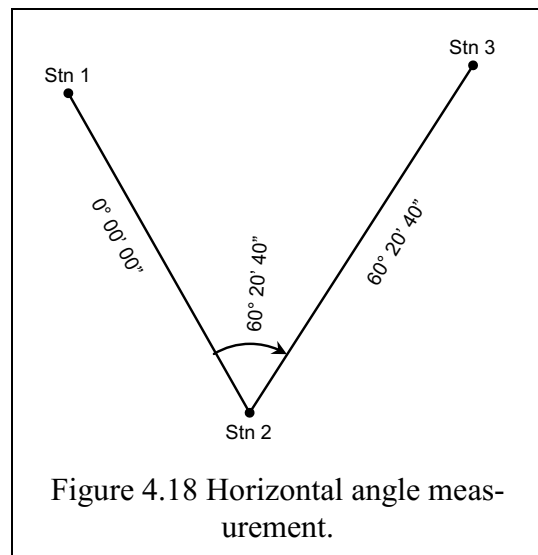

levelled at Stn 2 as discussed in Section 4.1, the instrument's telescope is pointed to Stn 1 while on Face Left (FL).

Ensure that the cross-hairs of the instrument accurately bisect the centre of the reflector at Stn 1 then lock the instrument. The slow-motion screw is used to perfect the bisection. With the instrument locked, the reading on the instrument is now set at $0^{\circ} 00' 00''$ (or any arbitrary reading). This is the back sight (BS) reading.

Taking into consideration that angular measurements in surveying are performed clockwise, unlock the instrument and slowly turn it towards Stn 3. Bisect the reflector's centre using the cross-hairs and then lock the instrument and sight the target with the slow-motion screws. The horizontal reading of the instrument (HAR for Sokkia) will now indicate $60^{\circ} 20' 40''$, i.e., the fore sight (FS) reading. The equivalent vertical angle can also be read on the instrument given as ZA (for Sokkia).

The horizontal angle Stn 1-Stn 2 – Stn 3 is given as the difference between FS and BS, i.e., angle (Stn 1-Stn 2-Stn 3) = FS-BS = $60^{\circ} 20' 40'' - 0^{\circ} 00' 00'' = 60^{\circ} 20' 40''$.

In Example 5.1 of section 5.3, measurement of angles in both Face Left (FL) and Face Right (FR) and the booking of the measured angles are illustrated. Students are encouraged to thoroughly study this example. Note that in this Example, the booking format is just one type of the several types in use. Also, note that the angle Stn 1-Stn 2- Stn 3 should be measured several times with different starting circle readings to Stn 1 and the mean taken. For example, if, instead of the reading Stn 2 - Stn 1 being $0^{\circ} 00' 00''$, it can now be set to $60^{\circ} 20' 40''$ and the reading to Stn 3 now read as $120^{\circ} 40' 30''$ giving the measured horizontal angle Stn 1 - Stn 2 - Stn 3 as FS-BS = $120^{\circ} 40' 30'' - 60^{\circ} 20' 40'' = 60^{\circ} 19' 50''$.

The measured horizontal angle Stn 1-Stn 2 - Stn 3 now becomes the mean of the two angles $(60^{\circ} 20' 40'' + 60^{\circ} 19' 50'')/2 = 60^{\circ} 20' 15''$. The advantage of repeated measurement lies in the increased redundancies and improved precision.

4.6 Combined Total Station Measurements

Measurement with the Total Station provides the vector components; direction, vertical angle, and distance. Proper recording of this data is vital to the successful conduct of observations at a point. Apart from the measurements, other components of the session need to be measured and recorded.

4.6.1 Station Records

All information pertinent to the occupied station needs to be recorded in a Field Book.

1. Task, personnel, date.
2. Name, description, location, positional data (coordinates, RL), access and station diagram (for later recovery).
3. Instrument data; make, model, serial number
4. Set-up data; height of instrument (HI) above station, prism constant, atmospheric corrections applied.
5. Target data; prism make, model, S/N. Height of target (HT) above ground point.
6. Control points observed; name, description, location, positional data (coordinates, RL), access and station diagram (for later recovery).
7. Orientation method; points used, method used (random, magnetic meridian, local grid). Points used to establish orientation, back-sight (BS) description.

4.6.2 Recording Observations

Observations are recorded in a field book for later reduction of the data. The data must be recorded accurately by the booker, ensuring consistency in multiple measurements. To stable

targets distances will not vary by more than a few millimetres, and over reciprocal lines the agreement with the forward observations should be very similar.

It is basically impossible to re-set over a point once the instrument has been moved. Generally the entire task must be repeated. Be sure you have all the data before you move to the next point.

4.6.3 Example Recording of Observations from an Initial Station

Table 4-2 is an example of a field book.

Table 4-2 Example field book.							
Stn 1001, 25mm peg at G/L			Task: Determine position by distances			21/11/2016	
TS Sokkia	SET530RK3	S/N 08/7		Prisms: APS12. PC -30			
GROUP: Fri 3-6		Observer:	B Lee		Booker:	A. Smith	
BRG	360° Mag meridian 358°21'10"			PC -30	PPM = 10	HI	1.550
AT/TO		HAR	ZA	S	H	V	Remarks
	AT	1001					HI = 1.585
B/S: SE 105	L	19 25 10			B/S to corner BLD 105		
	Mean	19 25 23					
SE 105	R	199 25 36					
Mean incl angle: SE 105 - 705A 42 52 57							
705A	L	62 18 35	90 36 50	65.428			HT = 1.587
	Mean	62 18 20					
705A	R	242 18 45	269 23 20	65.429			
Incl. Angle 705A - C400 76 22 20							
C400	L	138 40 35	92 11 20	59.583			HT = 1.535
	Mean	138 40 40					
C400	R	318 40 45	267 48 30	59.584			
Side shots. FL only HT = HI							
NE 204	L	118 53 15	95 51 35	31.047			HT = 1.550
D/S 134	R	150 33 45	89 25 50	29.868			

4.7 Computations

4.7.1 Manipulating VECTORS

Coordinate system calculations.

There are two basic survey calculations which confront us when using co-ordinates.

(1) The Join Calculation

Given the co-ordinates of two points A and B, determine the **bearing** and **distance** between them.

- Convert RECTANGULAR to POLAR vector.

(2) The Polar Calculation

Given the co-ordinates of a point A (E_A, N_A) together with the bearing and distance from point A to point B, determine the co-ordinates of point B (E_B, N_B).

- Convert POLAR vector to RECTANGULAR coordinates.

In Figure 4.19, the coordinates of points A and B are represented by (E_A, N_A) and (E_B, N_B), respectively. The bearing of AB is shown as θ_{AB} (i.e. an angle clockwise from the north in the first quadrant). Distance $AB = D_{AB}$.

Notice that the direction of the vector is indicated by the vector subscripts. To calculate the intended vector, the convention is:

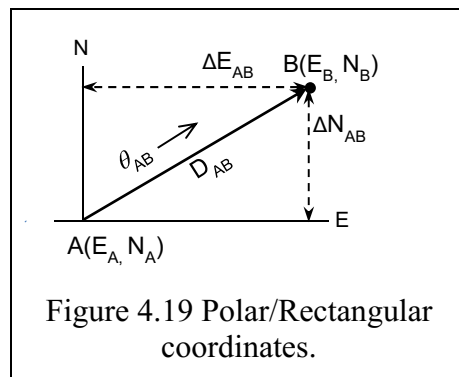

The bearing θ_{AB} is the direction **from A to B**.

The distance $AB = D_{AB}$ is the distance **from A to B**.

Self-evident maybe, but in vector terms, the distance $BA = D_{BA}$ is negative. ($D_{BA} = -D_{AB}$).

In expressing the coordinate **differences**, i.e. ΔE_{AB} and ΔN_{AB} , the difference convention is:

the point you are going **to** minus the point you are coming **from**.

$$\Delta E_{AB} = E_B - E_A \text{ and } \Delta N_{AB} = N_B - N_A$$

4.7.1.1 The Join Calculation.

(The polar vector *joining* the two rectangular coordinates)

[RECTANGULAR to POLAR].

Given: The co-ordinates of A (E_A, N_A) and the co-ordinates of B (E_B, N_B). (See Figure 4.20).

Find: The bearing and distance A to B
i.e. θ_{AB}, D_{AB} .

Solution: Find the **angle** formed with reference to the **North/South** axis of the reference frame.

$$\Delta E_{AB} = E_B - E_A$$

$$\Delta N_{AB} = N_B - N_A$$

$$\text{Tan } \angle A = \frac{\Delta E_{AB}}{\Delta N_{AB}}$$

$$\theta_{AB} = \text{Atan} \left(\frac{\Delta E_{AB}}{\Delta N_{AB}} \right) \text{ in the correct quadrant.}$$

$$D_{AB} = \frac{\Delta E_{AB}}{\text{Sin}(\theta_{AB})} = \frac{\Delta N_{AB}}{\text{Cos}(\theta_{AB})} = \sqrt{\Delta E_{AB}^2 + \Delta N_{AB}^2} \text{ hypotenuse from Pythagoras.}$$

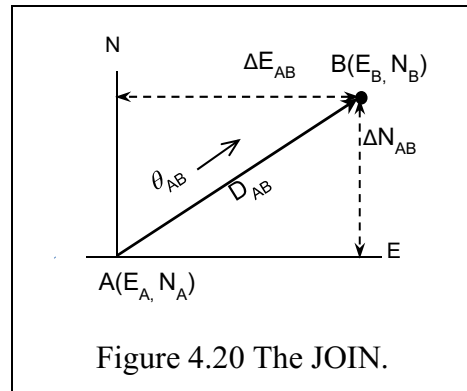

Figure 4.20 The JOIN.

From the angle, the arctangent, how do we obtain the bearing of AB in all 4 quadrants?

Evaluate the **angle** generated. Examine the **sign** of the result.

Tan is positive in the 1st and 3rd quadrants.

Thus, our method uses the **sign** of the NORTH component (ΔN).

$\Delta N > 0$ (**positive**): $\theta_{AB} = 360 + \angle A$. If $\theta > 360$: $\theta = \text{MOD}(\theta, 360)$

$\Delta N < 0$ (**negative**): $\theta_{AB} = 180 + \angle A$. ($90 < \theta < 270$)

The $\text{MOD}(\theta, 360)$, or **MODULO 360** (θ), operator reduces the value of θ to a range $0 \rightarrow 360$.

($0 > \theta > 360$)

$\Delta N = 0$ (**zero**): $\text{Atan} \left(\frac{\Delta E}{0} \right)$ cannot be evaluated;

calculators give a "Divide by 0" error message.

$\text{Tan}(90^\circ)$ is undefined as $\lim_{\theta \rightarrow 90^\circ} [\text{Tan } \theta] \rightarrow \infty$ (tends to in-

finitly)

thus for $\Delta N = 0$, $\theta = 90^\circ$ or 270° .

(For convenience we say $\text{Tan}(90^\circ) = \infty$).

$\Delta E = 0$: $\text{Atan} \left(\frac{0}{\Delta N} \right)$ is evaluated correctly as 0° ;

and if $\Delta N < 0$ (negative) then $\theta = 180^\circ$

Quadrant I, IV
Quadrant II, III

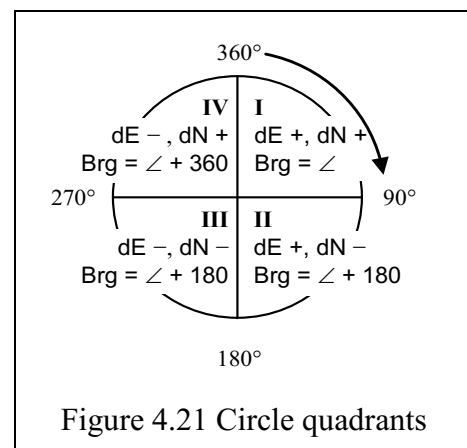

Figure 4.21 Circle quadrants

Test statement

if $\Delta N = 0$ AND if $\Delta E > 0$ then $\theta = 90^\circ$

else if $\Delta E < 0$ then $\theta = 270^\circ$

Illustrating how we obtain the bearing of AB in all 4 quadrants.

Quadrant 1: (0 - 90°). Tan $\angle A$ is POSITIVE

$$\tan \angle A = \frac{\Delta E_{AB}}{\Delta N_{AB}}, \Delta N > 0 (+ve)$$

$$\theta_{AB} = 360 + \text{Atan} \left(\frac{\Delta E}{\Delta N} \right)$$

$$\theta_{AB} = 360 + (+\angle)$$

$$\theta_{AB} = \text{MOD}(\theta, 360)$$

Quadrant 2: (90° - 180°). Tan $\angle A$ is NEGATIVE

$$\tan \angle A = \frac{\Delta E_{AB}}{\Delta N_{AB}}, \Delta N < 0 (-ve)$$

$$\theta_{AB} = 180 + \text{Atan} \left(\frac{\Delta E}{-\Delta N} \right)$$

$$\theta_{AB} = 180 + (-\angle)$$

Quadrant 3: (180° - 270°). Tan $\angle A$ is POSITIVE

$$\tan \angle A = \frac{\Delta E_{AB}}{\Delta N_{AB}}, \Delta N < 0 (-ve)$$

$$\theta_{AB} = 180 + \text{Atan} \left(\frac{-\Delta E}{-\Delta N} \right)$$

$$\theta_{AB} = 180 + (+\angle)$$

Quadrant 4: (270° - 360°). Tan $\angle A$ is NEGATIVE

$$\tan \angle A = \frac{\Delta E_{AB}}{\Delta N_{AB}}, \Delta N > 0 (+ve)$$

$$\theta_{AB} = 360 + \text{Atan} \left(\frac{-\Delta E}{\Delta N} \right)$$

$$\theta_{AB} = 360 + (-\angle)$$

Join Calculation

Given: The co-ordinates A (E_A, N_A) and B (E_B, N_B)

Find: The bearing and distance A to B

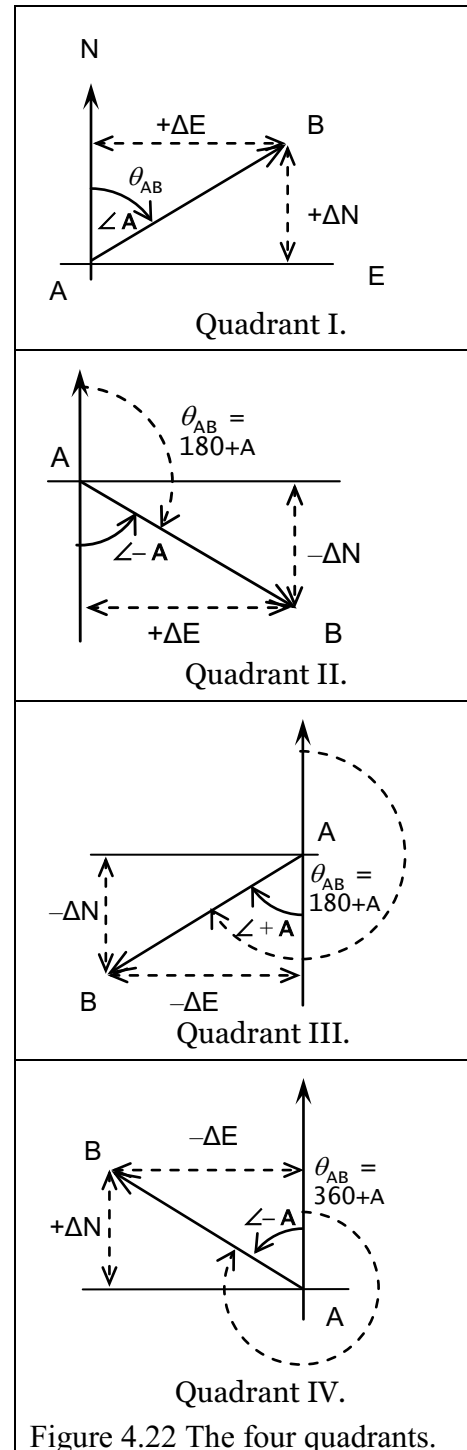

Figure 4.22 The four quadrants.

Format:

To: E_B N_B $\tan \angle NAB = \frac{\Delta E_{AB}}{\Delta N_{AB}}$, $\theta_{AB} = \text{Atan}\left(\frac{\Delta E_{AB}}{\Delta N_{AB}}\right)$ in quadrant

— From: E_A N_A $D_{AB} = \sqrt{\Delta E_{AB}^2 + \Delta N_{AB}^2}$

Difference $\frac{\Delta E_{AB}}{\Delta N_{AB}}$

CHECK: $E_B = E_A + D_{AB} \cdot \text{SIN}(\theta_{AB})$
 $N_B = N_A + D_{AB} \cdot \text{COS}(\theta_{AB})$

Method: **to find θ_{AB} , D_{AB} .**

1) Find the coordinate difference $\Delta E_{AB} = E_B - E_A$ and $\Delta N_{AB} = N_B - N_A$

2) calculate the Tangent of the **angle:** $\tan \angle A = \frac{\Delta E_{AB}}{\Delta N_{AB}}$

using **sign** of ΔE_{AB} and ΔN_{AB}

3) find the Arctangent of the **angle:** $\angle A = \text{Atan}\left(\frac{\Delta E_{AB}}{\Delta N_{AB}}\right)$

calculate θ_{AB} **in correct quadrant**

4) and distance using Pythagoras' theorem $D_{AB} = \sqrt{\Delta E_{AB}^2 + \Delta N_{AB}^2}$.

Worked Example 4.1

Compute the bearing and distance from A to B (see Figure 4.23)

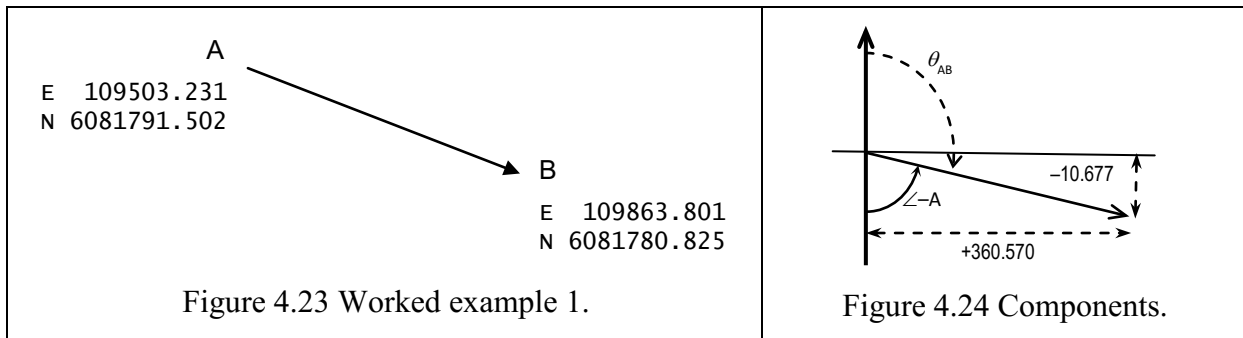

	Easting	Northing
B	109863.801	6081780.825
– A	109503.231	6081791.502
	+360.570	–10.677

$\Delta N < 0$

Figure 4.23

Figure 4.24

$\angle A = \text{Atan}(360.570 / -10.677) = \text{Atan}(-33.7707)$ $\angle A = -88^\circ 18' 14''$ in quad II

$\theta_{AB} = 180 + (-88^\circ 18' 14'')$ $\theta_{AB} = 91^\circ 41' 46''$

$D_{AB} = \sqrt{360.57^2 + (-10.677)^2}$

$D_{AB} = 360.728$

CHECK.

$E_B = E_A + D_{AB} \cdot \text{SIN}(\theta_{AB})$
 $= 109503.231 + 360.728 \cdot \text{Sin}(91^\circ 41' 46'')$
 $= 109503.231 + 360.570$

$E_B = 109863.801$ ✓

$N_B = N_A + D_{AB} \cdot \text{COS}(\theta_{AB})$
 $= 6081791.502 + 360.728 \cdot \text{Cos}(91^\circ 41' 46'')$
 $= 6081791.502 + (-10.677)$

$N_B = 6081780.825$ ✓

4.7.1.2 The Polar Calculation

(The coordinates created by a *polar* vector from a point)
[POLAR to RECTANGULAR].

Polar Calculation.

Given: A (E_A, N_A)

- together with the polar vector
- the bearing/distance A to B (Figure 4.25).

Find: The coordinates of B (E_B, N_B)

Now, $\Delta E_{AB} = D_{AB} \cdot \sin(\theta_{AB})$
 $\Delta N_{AB} = D_{AB} \cdot \cos(\theta_{AB})$
 $E_B = E_A + \Delta E_{AB}$
 $N_B = N_A + \Delta N_{AB}$

Format:

	Brg/Dist	E	N
A	θ_{AB}	E_A	N_A
	D_{AB}	$\pm \Delta E_{AB}$	$\pm \Delta N_{AB}$
B	SUM	E_B	N_B

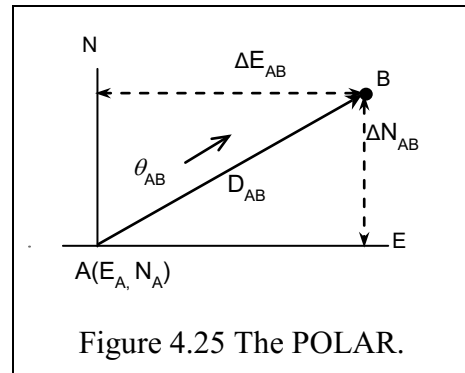

Worked example 2.

Figure 4.26

Given: $E_A = 548979.504, N_A = 6444421.068$

$\theta_{AB} = 221^\circ 03' 00''$

$D_{AB} = 522.211$

$\sin(221^\circ 03' 00'') = -0.675617$ $\cos(221^\circ 03' 00'') = -0.754137$

$\Delta E_{AB} = 522.211 \times -0.675617 = -342.945$

$\Delta N_{AB} = 522.211 \times -0.754137 = -393.818$

Find: Co-ordinates of B (E_B, N_B)

	Brg/Dist	E	N
A		548979.504	6444421.068
	$221^\circ 03' 00'', 522.211$	$\Delta E -342.945$	$\Delta N -393.818$
B		548636.559	6444027.250

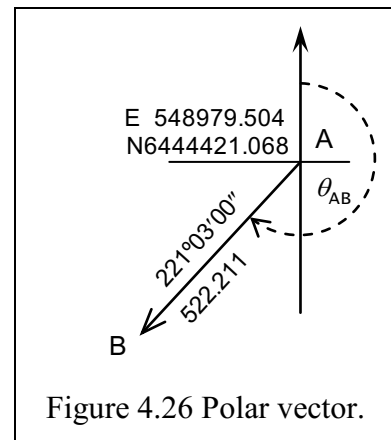

4.7.2 Using the POLAR and RECTANGULAR Function on a Calculator

Calculators approved for engineering courses have built in functions to solve the join and polar problems, which are problems of conversion of a vector between a rectangular coordinate system to a polar coordinate system.

The methods are illustrated in the Appendix A3: **Survey Calculations on the HP 10s+**.

The HP10s+ is well suited to the surveying course because it stores the results of the POL(and REC(functions in memory for later recording or use in continued calculations.

4.7.3 Reduction of Electronically Measured Distance to the Spheroid

We have examined various aspects of errors that can occur in EDM derived distances, and it is best to examine the steps necessary to reduce a raw distance measured by EDM to the eventual mapping plane. In Australia, the eventual mapping projection, the MGA94, is based on the GDA94 using the GRS80 datum. From these final coordinates we can transform to other required projections.

Chapter 12 on coordinate transformations, illustrates the transformation process between various coordinate sets. However, to produce coordinates, the observed distances must be reduced to the mapping plane, eventually to the MGA94. The process is referred to as the “Reduction of distance to the spheroid/ellipsoid”.

Under normal observation conditions, measuring over distances up to a few hundred metres, there are four corrections to be made to a measured slope distance before it is incorporated in the map projection calculations.

Mapping on the local plane, regardless of height above the geoid or the ellipsoid.

1. Reduction of slope distance to horizontal distance, as shown previously:
 - *Horizontal distance = slope distance x SIN(Zenith Angle)*
 - the level terrain distance from the observation point.

This is where we stop the distance reductions in producing our plan on the local plane.

The continuation of reduction of distances and directions for mapping to a projection is the purview of the surveyor.

The local plane may be expanded to a local projection over an extended area, the main object being that the scale factor over the projection is very close to 1, and the grid convergence spread evenly across a central meridian.

Mapping on the projection, defined by projection parameters.

2. Reduction of level terrain distance to geoidal (sea level) distance.
 - application of a height correction.
3. Reduction of geoidal distance to ellipsoidal distance.
 - application of geoid/ellipsoid height correction.
4. Application of a point or line **scale factor** applicable to the distance from the central meridian.

Reduction to the ellipsoid

Reduction of the wave path distance, d_1 , (observed EDM distance) to the ellipsoidal chord distance, d_3 , using Clarke’s (1966) formula:

$$d_3 = [(d_2^2 - (h_A - h_B)^2) / (1 + h_A R_\alpha)(1 + h_B R_\alpha)]^{(1/2)}$$

The reduced wavepath distance, d_1 , and the reduced slope distance, d_2 , are inseparable out to 15Km. Note that h_A and h_B are ellipsoidal heights; R_α is the radius of curvature the line azimuth. Figure 4.27 illustrates the relationship between various distances.

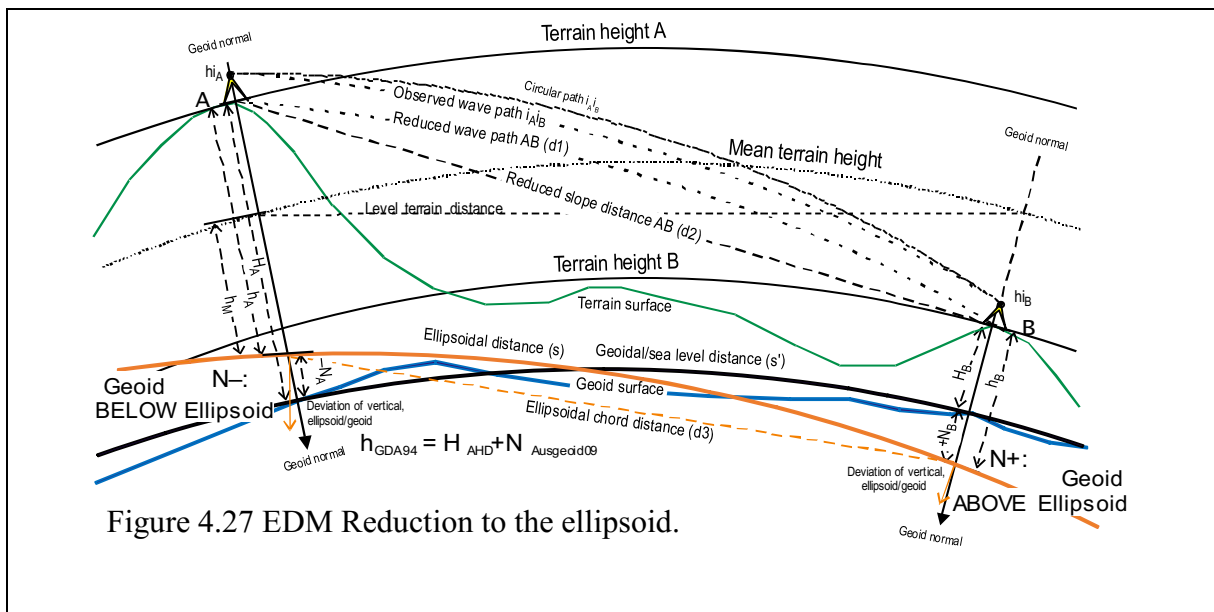

Figure 4.27 EDM Reduction to the ellipsoid.

Height values on the AHD, H_A and H_B have to incorporate the ellipsoid/geoid separation N . Over a small area common values for N (from Geoscience Australia) and R_α (6,366,000 at

32°S) would suffice for the reduction.

The ellipsoidal distance, s , equals the ellipsoidal chord distance, d_3 , for our EDM to 4,000m.

4.8 Observation Blunders and Mistakes

The most likely sources of errors in observations will come from:

1. Incorrectly plumbed over point;
 - plate levels, unchecked centring collimation, **damaged plummet assembly**.
2. Incorrect prism constant setting in EDM.
3. Incorrect height of instrument and target (HI, HT).
4. Incorrect EDM meteorological settings.
5. Incorrect observation parameters set for horizontal distance (H);
 - scale factor, C&R correction, sea level correction
6. Parallax in pointing to target,
 - check reticule and object focus.
7. Gross data recording errors from data screen
8. Incorrectly identified data point.
9. Incorrect recording of control point data
10. Transcription errors in field book
 - poor character formation, printing, transposition

4.9 Concluding Remarks

This Chapter introduced you to the Total Station instrument used by surveyors to measure distances and angles. The chapter elaborated on distance and angular measurement procedures and their associated errors. Finally, the concept of computing rectangular coordinates (Eastings and Northings) given polar coordinates (distances and bearings) and vice versa was introduced. Note that while computing the bearings, it is important to choose the correct quadrant out of the four quadrants. Students should make sure they go over this chapter thoroughly as it forms the foundation needed to understand the remaining chapters of the book.

4.10 Reference to Chapter 4

1. Clark, D. (1966). Plane and Geodetic Surveying. London, England, Constable and Company, Ltd.
2. ISCM. GDA94 - Technical Manual, V2.4. www.icsm.gov.au/gda/tech.html

Chapter 5 Traversing

5.1 Introductory Remarks

This Chapter introduces you to the theory and practical skills of traversing, a process of determining horizontal controls. For civil and mine engineering, traverse finds use in:

- ✓ Establishing horizontal controls i.e., known positions (Eastings and Northings).
- ✓ Horizontal controls for topographic and detail (i.e. pre-engineering) surveys (i.e., the part that will be undertaken in the practical discussed in Appendix A2-3).
- ✓ To establish planar coordinates of points during constructions (set-out).
- ✓ For topographical purposes.
- ✓ For area and volume computations
- ✓ Ground control for photogrammetric mapping.

Working through the materials of this Chapter and the workshop materials in Appendix A2-3 and A2-4, you should:

- Know what control survey entails and their roles in engineering and mine surveying.
- Explain what traverse is and know the field methods and computational methods related to it.
- Know the types of traverses and perform all the calculations that are required to obtain traverse coordinates from measured angles and distances.
- Understand the usefulness of traversing in Civil Engineering.

Essential references include Uren and Price (2010, Chapter 6), Schofield and Breach (2007, Chapter 6) and Irvine and Maclennan (2006, Chapter 8).

5.2 Definition and Applications

Traversing is a surveying technique that employs a Total Station (Chapter 4) to determine the planar positions (Easting and Northing: E_B and N_B in Figure 5.1 below) of control points or setting out points using measured angles and distances (d_{AB} and θ below). For vertical controls, you have already learnt the levelling technique in Chapter 2.

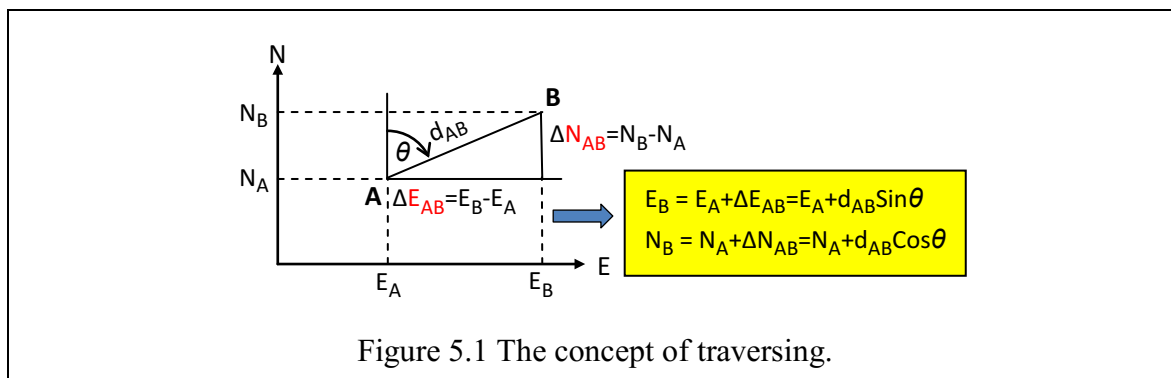

Control points.

- ✓ For ALL civil and mine engineering works, control survey is carried out to fix positions of reference points used in mapping and setting out.
- ✓ For most construction sites, controls are made up of vertical and horizontal positions.
- ✓ For large engineering projects, the Earth's curvature should be taken into account. This is done using global navigation satellite systems GNSS (and will be covered in Chapter 10).

Traverses can either be open or closed.

- Closed-route or link traverse starts from a known point and end at another known point (Figure 5.2).
- If it starts and ends at the same point, i.e., Figure 5.3, it is called a loop traverse.
- Another type of traverse includes radiation, or side shot, traverse where all points are uniquely measured and no redundancy exists (Figure 5.4).

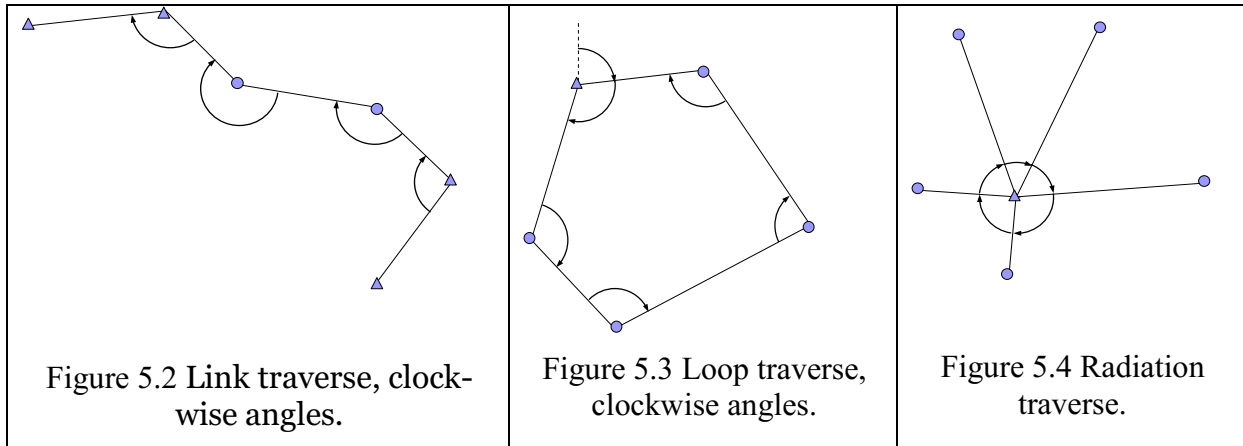

5.3 Traverse Procedure

Traverse procedure entails angular and distance measurements. The Total Station (Fig 4.1a) is placed at point TPA and pointed at a target stationed at TP1. The known direction from TPA-TP1 is set in the instrument as described in Section 4.1. Then measure the angles TP1-TPA-B on face left (FL) and right (FR) (see example 5.1 in Section 5.4). Measure the distance TPA-B several times. The target at B then moves to C, that of TP1 to TPA and the instrument to B. Set the bearing B-TPA (obtain by adding or subtracting 180° to the forward bearing TPA-B). Now, measure the angle TPA-B-C on both faces (left and right) as before, and the distance B-C several times. The target at C then moves to D, that at TPA to B, and the instrument to C. Measure the angle B-C-D and the distance C-D as done in the previous step. Next, move the instruments and the targets to measure the angle C-D-E and the distance D-E. Finally, with the Total Station at E, the final angle D-E-F (known target) is measured. The final angles should be the measured direction E-F known target, which can be compared to the known direction to get the angular misclose.

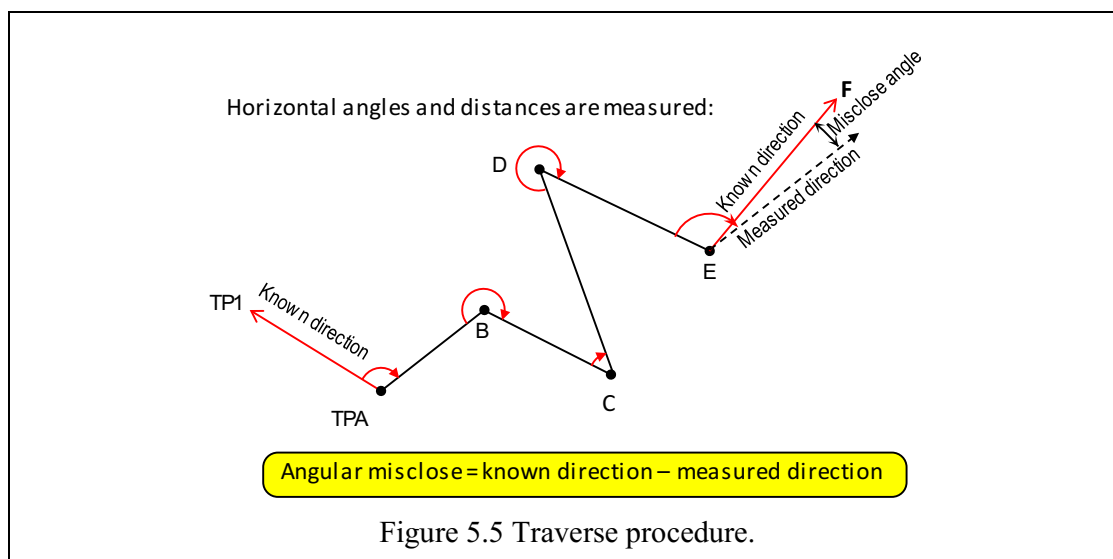

In the Figure 5.5, the points occupied by the Total Station are known as traverse stations. They can either be temporary or permanent points. They can either comprise:

- Wooden stakes driven flush with the ground and with a nail driven on top
 - ✓ Large nail on soil
 - ✓ Concrete nail
 - ✓ Cut-cross scribed in concrete
- If they are to be used later, stations should be referenced or witnessed with appropriate horizontal steel band or tape measurements and the necessary field notes made.
 - ✓ Geodetic control points may be used in the traverse. In Australia, they are known as Standard Survey Marks (SSMs). At Curtin University, the points are known as Curtin Survey Marks (CSMs).

5.4 Field Notes Reduction

Field reduction for traversing involves correcting the measured angles and distances for effects of random errors.

- Angles
 - ✓ Reduce FL and FR readings to their mean value
 - ✓ This is usually already done in the field book
 - ✓ Must be careful to use the mean value (rather than the FL value) for the traverse computations—this emphasises the need for neat, accurate field notes.
- Distances
 - ✓ If repeat measurements are made, their mean values should first be calculated
 - ✓ All measured distances must be corrected.
 - ✓ When steel band are used, they must be corrected for slope, length, temperature, tension and sag.
 - ✓ When EDM are used, the slope distances must be corrected for the prism constant, scale errors and cyclic errors and reduced to horizontal distances (see Section 4.3).

Example 5.1 Angular measurements and reduction. The Total Station will be set and levelled at point B. The instrument is then pointed at a target placed at point A and the first reading entered in the instrument as discussed in Section 4.2. This reading is booked under face left (FL) as $0^{\circ} 07' 22''$. Rotate the instrument on face left (FL) still to point at a target at point C. Lock the instrument and aim the cross hairs to bisect the centre of the target at point C. The reading on the instrument is $192^{\circ} 23' 38''$ and is booked under face left (FL). Now, the reading on face left is complete. Unlock the telescope and turn it to face you. With the telescope facing you, rotate the instrument so that the telescope is once again facing point C. The instrument is now on Face Right (FR) and the reading displayed differs with that of FL by 180° . This reading, $12^{\circ} 23' 44''$ is now booked under the column of Face Right but under the row of C. Finally, rotate the instrument back to the starting point A and take the last reading $180^{\circ} 07' 18''$ which is recorded under the column of Face Right under the row of A. This completes one set of reading measured on both faces (FL and FR).

Taking a closer look at the readings of A, Figure 5.6, you will notice that the difference occurs only in the seconds' part. The mean of this seconds are taken and the face left reading with the mean of the seconds, i.e., $0^{\circ} 07' 20''$ is booked under the mean face left value. This is repeated for face right and indicated as $192^{\circ} 23' 41''$. Now the measured angle ABC is obtained by taking the difference between the two means to give $192^{\circ} 16' 21''$. Another set of reading is taken as shown in Fig. 5.6 and finally the mean of the sets is taken. Several readings of the distances are also taken and their means taken. The angles and distances are then subsequently used in the Bowditch adjustment as discussed in Section 5.5.4.

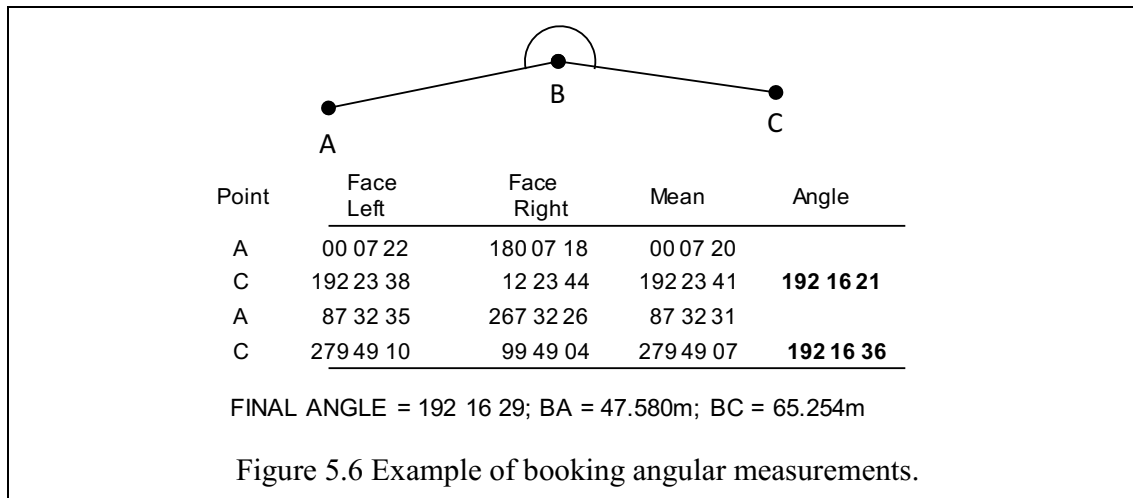

5.4.1 Angular Misclose

Traverse adjustment is done in 2 steps:

- ✓ Balance the angles
- ✓ Traverse adjustment

If no gross errors exist in the angles and all systematic effects have been eliminated by

- ✓ Instrument calibration,
- ✓ Reducing FL/FR observations to their mean,
- ✓ Careful levelling,
- ✓ Careful instrument and target centring,

then only random errors will exist. The random errors cause the sum of interior angles to deviate from the theoretical value. The sum of interior angles of a traverse should equal

$$\sum \text{Internal angles} = (n - 2) \cdot 180,$$

where n is the number of angles (or sides). For an instrument having a stated accuracy of δ in seconds (") (e.g. 1" for a SET1, 5" for a SET530), the allowable angular misclosure, ε , is

$$\varepsilon = \delta \sqrt{n}.$$

If the angular misclosure is found to be acceptable, then a correction can be applied to each angle so that the sum of the adjusted angles is correct. The textbooks suggest several methods for determining the corrections

- ✓ Arbitrary: Not recommended.
- ✓ Larger corrections for angles observed in poor conditions: subjective.
- ✓ Average (mean) value: logical and recommended.

It should be noted that corrections should not be applied in proportion to the size of the angle, since errors due to pointing, reading and instrument and target centring are independent of the size of the angle. If the total angular misclosure is $\pm\varepsilon$, then the correction applied to each angle is given by

$$c = \mp \frac{\varepsilon}{n}$$

Note the negative/positive sign! It is the opposite from the plus/minus sign of the misclose, ε , indicating that the correction is the opposite sign from the misclosure.

Usually the corrections are rounded to the nearest second. Due to the accumulation of rounding errors, one or two corrections may have to be (arbitrarily) modified by $\pm 1''$ so that the sum of adjusted angles is correct. The sum of adjusted angles should be computed afterward as a check.

5.4.2 Bearing and Coordinates Computations

The bearing of each line around the traverse is calculated in the clockwise direction. Two methods can be used, i.e.,

- ✓ Computing the back bearing and subtracting the interior angle, e.g.,
 $(180^\circ + 60^\circ 38' 32'') - 81^\circ 53' 34'' = 158^\circ 44' 58''$.
- ✓ Deflection of the interior angle (see example below).

Example 5.2 (Deflection of the interior angle method): This is done in three steps.

Step 1: Initial bearing and clockwise interior angles are given. (Figure 5.7a)

AB = $60^\circ 38' 32''$

$\angle A = 49^\circ 03' 23''$

$\angle B = 81^\circ 53' 34''$

$\angle C = 49^\circ 03' 03''$

Step 2: Deflection angles are calculated from clockwise interior angles (Figure 5.7b)

(Defl. angle = $180^\circ - \text{int. angle}$).

$B' = 180^\circ - 81^\circ 53' 34'' = 98^\circ 06' 26''$

$C' = 180^\circ - 49^\circ 03' 03'' = 130^\circ 56' 57''$

$A' = 180^\circ - 49^\circ 03' 23'' = 130^\circ 56' 37''$

Step 3: Calculated bearings (Figure 5.7c)

(Previous bearing + deflection angle,

e.g., $BC = AB + \text{defl}_B$)

$BC = 60^\circ 38' 32'' + 98^\circ 06' 26''$

$= 158^\circ 44' 58''$.

$CA = 158^\circ 44' 58'' + 130^\circ 56' 57''$

$= 289^\circ 41' 55''$.

$AB = 289^\circ 41' 55'' + 130^\circ 56' 37''$

$= 420^\circ 38' 32''$

$AB - 360^\circ = 60^\circ 38' 32''$. Check.

(Always add the last angle to check

against the initial bearing.)

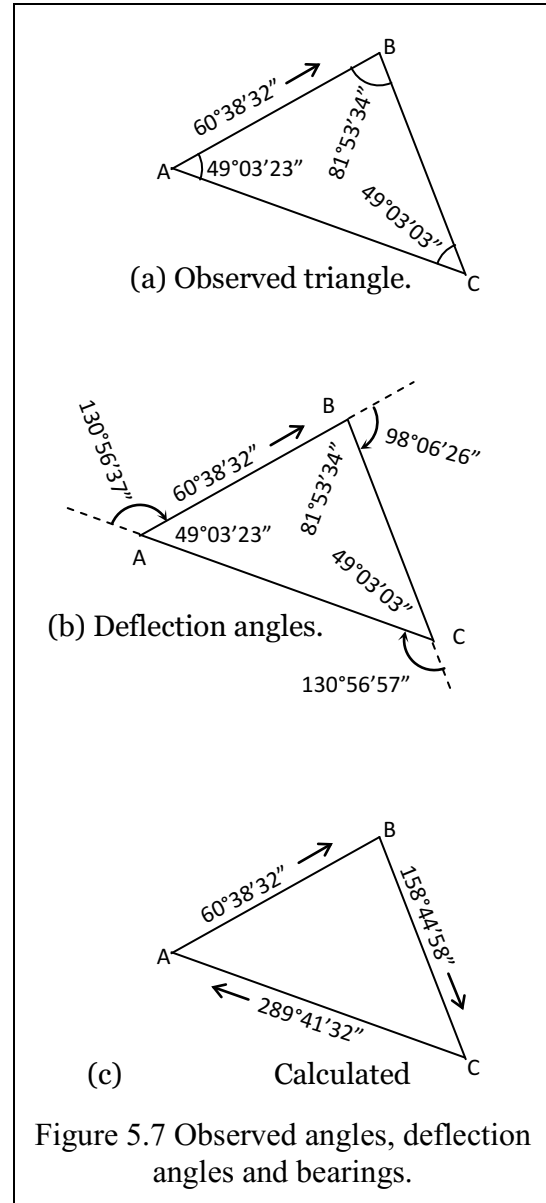

5.4.3 Traverse Misclose: Bowditch Adjustment

To compute the Eastings and Northings (E_B and N_B) of station B given those of A, measured distance d_{AB} and angles θ (see Example 5.1 and Fig. 5.1). This calculation is performed for

each traverse line. Similar to the loop levelling where $\Delta H=0$, in traversing, the sum of ΔN and ΔE of all n traverse sides should equal zero, i.e.,

$$\sum_{i=1}^n \Delta E_i = 0, \quad \sum_{i=1}^n \Delta N_i = 0$$

Due to random errors, the sum will deviate from zero, leading to a linear misclose (Figure 5.8), i.e.,

$$\sqrt{\left(\sum_{i=1}^n \Delta E_i\right)^2 + \left(\sum_{i=1}^n \Delta N_i\right)^2} \neq 0$$

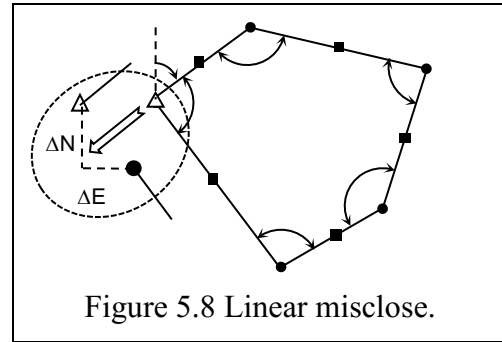

Figure 5.8 Linear misclose.

The fractional linear misclosure, the ratio of the sum of side lengths to misclosure length, gives a measure of traverse precision.

$$1 \text{ in } \frac{\sum_{i=1}^n d_i}{\sqrt{\left(\sum_{i=1}^n \Delta E_i\right)^2 + \left(\sum_{i=1}^n \Delta N_i\right)^2}}$$

- Each line of the traverse is adjusted with a correction opposite in sign to the misclosure.
- The question then arises on how the overall traverse misclosure should be distributed to each line. The options include equal adjustment, transit method, least-squares method or Bowditch method.
 - ✓ In the Bowditch method, the corrections to each line are proportional to the side length.
 - ✓ This is the method we recommend although modern software incorporates least squares solutions.
- Bowditch method:

$$c_{E_i} = \mp d_i \frac{\sum_{i=1}^n \Delta E_i}{\sum_{i=1}^n d_i}, \quad c_{N_i} = \mp d_i \frac{\sum_{i=1}^n \Delta N_i}{\sum_{i=1}^n d_i}$$

- Note that the correction has the **opposite sign** of the misclosure (workshop in Appendix A1-4 will treat this in detail).
- After adjusting each side, the sum of ΔN and ΔE should be calculated as a check and should both equal zero.

5.4.4 Area Computations

The area of the figure should be calculated and reported in both m^2 and ha. The area is computed using coordinates' method (see Chapter 3). The general formula is given as:

$$Area = \left| \frac{1}{2} \left(\sum_{i=1}^n (E_i N_{i+1} - E_{i+1} N_i) \right) \right|$$

The figure must close back to the start point, i.e., E_1 and N_1 must appear twice.

The formula is computed as (Figure 5.9):

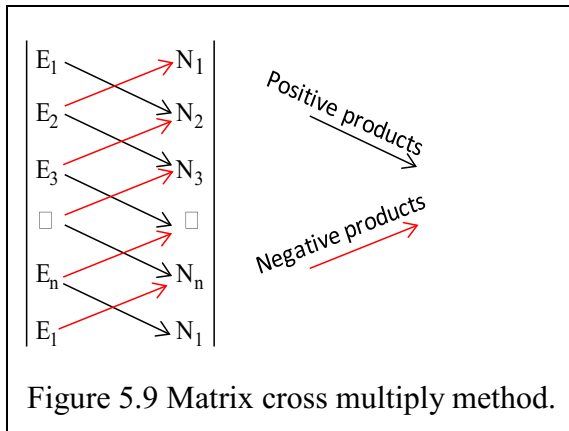

Remember to halve your answer.

The result may be positive or negative, it depends on the coordinate order. Area is always positive.

Some texts use a N, then E, column order to provide a positive answer in a clockwise traverse. However, the presented column format maintains the normal E, N coordinate order used in traversing, but gives a negative answer in a clockwise traverse. It saves transcription errors.

5.4.5 Summary of the Traverse Computation

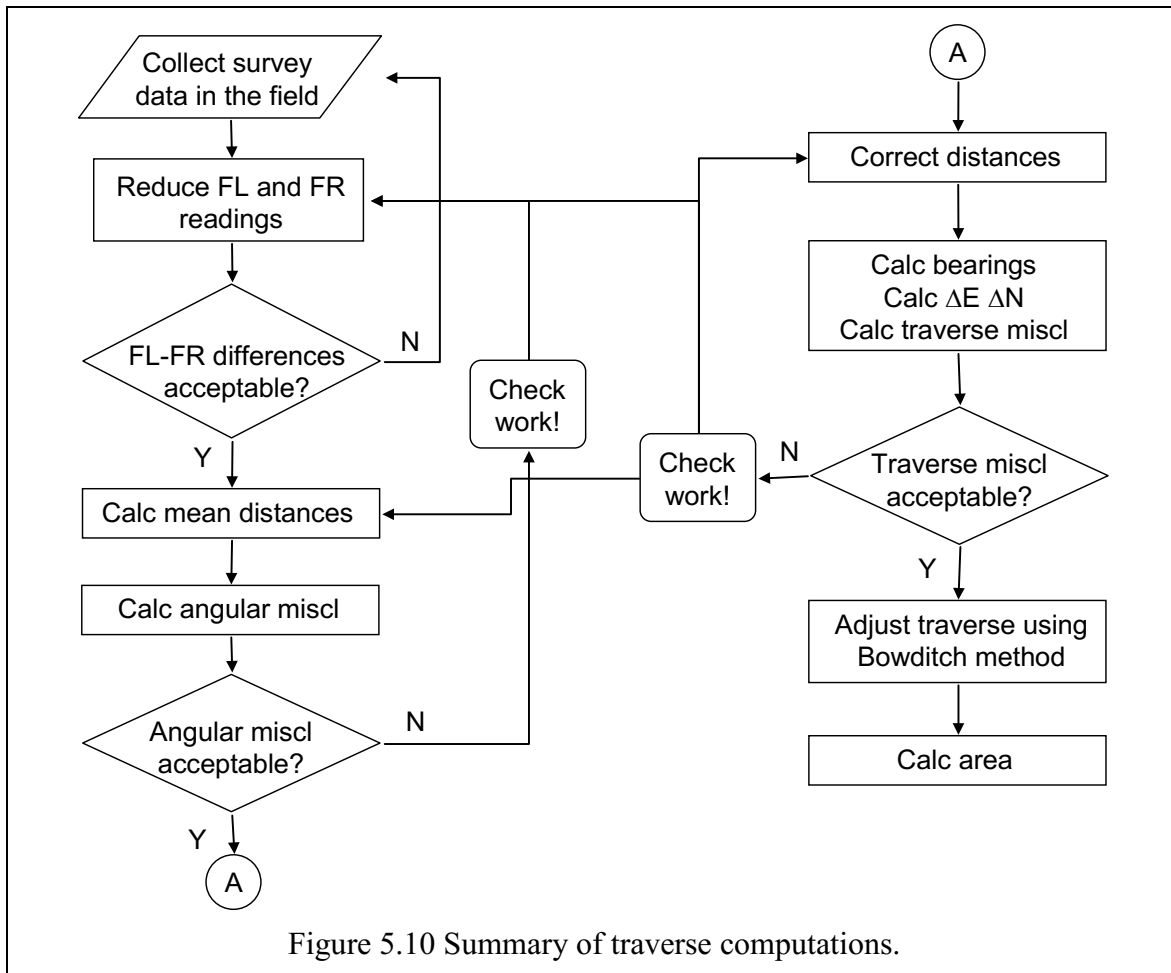

5.5 Example: Set-out and Adjustment of Control Points for Site Control

A control point, **CEM_00**, was established in Field Practical A2-3-1. The point was determined by observing to 705A and C400. The following extracts from the field book refer to the back sight to 705A.

Following the observation of a digital elevation model (DEM) for the design area, there is a need for the placement of site control points that can be used by other contractors. For this practical exercise you will establish two extra control points, **CEM_0A** and **CEM_0B**

Figure 5.11 using your initial control point, CEM_00, established in Field Practical A2 – 3 - 1. Prism sets with target plates will be set up on tripods over the control points CEM_0A and CEM_0B.

The triangle of points so established will be fully observed by reading directions and distances on both faces (FL and FR) of the Total Station at each control point. The observations from each control point will be made using the semi-forced centring technique whereby instruments and targets are swapped between tribrachs without disturbing the tripod set-up over the control point. Orientation of the control network will be established from the back sight (BS) observations to 705A.

At the initial control point, CEM_00, include face left (FL)/face right (FR) observations to your BS orientation point in your round of observations to the two other introduced control points. This will allow the mean angle between your BS and first control point to be calculated, and the **bearing** to the first control point to be established

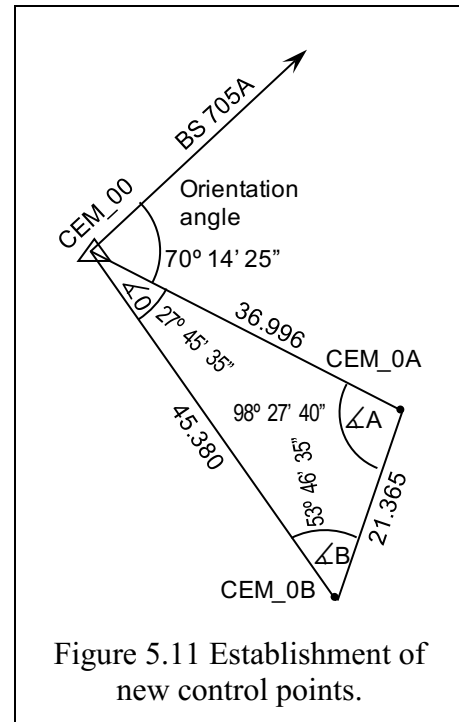

Figure 5.11 Establishment of new control points.

5.5.1 Field Book Observations and Reduction

Table 5-1 Calculation of mean angles and distances from field book, part a.

AT/TO		HAR	ZA	S	H	V	Remarks	
AT	CEM_00	HAR			RL	16.035	HI = 1.585	
705A	L	47 51 50					B Sight	
	Mean	47 51 53						
705A	R	227 51 55					B Sight	
	Incl. Angle	70 14 27					Orientation angle to 705A	
CEM_0A	L	118 06 15	95 06 28	37.144	36.996	-3.307	HT = 1.563	
	Mean	118 06 20					RL A = RL CEM_00+HI+V·HT = 12.75	
CEM_0A	R	298 06 25	264 53 32	37.144	36.997			
	Incl. Angle	27 45 35					Angle at_00	
CEM_0B	L	145 51 50	95 16 04	45.571	45.379	-4.184	HT = 1.576	
	Mean	145 51 55					RL B = RL CEM_00+HI+V·HT = 11.86	
CEM_0B	R	325 52 00	264 43 34	45.572	45.380			
AT	CEM_0A	Change station to CEM_0A						HT = 1.563
CEM_0B	L	0 01 25	92 21 02	21.383	21.365	-0.877	HT = 1.576	
	Mean	00 01 30						
CEM_0B	R	180 01 35	267 38 58	21.382	21.364			
	Incl. Angle	98 27 40					Angle at_0A	
CEM_00	L	98 29 04	84 53 31	37.143	36.995	3.307	HI = 1.585	
	Mean	98 29 10						
CEM_00	R	278 29 16	275 06 29	37.144	36.996			
AT	CEM_0B	Change station to CEM_0B						HT = 1.576
CEM_00	L	0 01 25	84 43 57	45.573	45.381	4.184	HI = 1.585	
	Mean	00 01 30						
CEM_00	R	180 01 35	275 06 04	45.572	45.380			
	Incl. Angle	53 46 35					Angle at_0B	
CEM_0A	L	43 48 01	87 38 58	21.384	21.366	0.877	HT = 1.563	
	Mean	43 48 05						
CEM_0A	R	233 48 09	272 21 02	21.383	21.365			
	Σ angles =	179 59 50						

5.5.2 Network Adjustment Method

- a. at each control point, calculate directions and distances (see Example 5.1 in Section 5.4) as follows;
 1. obtain the mean direction to each the control points from the mean of the FL/FR observations,
 2. obtain the mean **angle** between the control points from the difference of the mean directions,
 3. obtain the mean vertical angle (as a zenith distance) from the FL/FR observations,
 4. obtain the mean slope distance of each observation,
 5. the resulting **horizontal** distance and **vertical** height difference to the other two control point targets.
 6. obtain the RLs of the two control points from the initial control point.
- b. for the network, calculating internal angles;
 1. the **sum** of the mean internal angles,
 2. the angular **misclose** for the network, compared with the sum of the internal angles of the plane figure,
 3. the **adjusted** internal angles after the even **distribution** of angular misclose as discussed in Section 5.4.1.
- c. for the network, calculating adjusted bearings;
 1. the **bearing** of the first control line by the addition of the mean angle to the BS bearing,
 2. the **bearing** of the other control lines by the addition of the adjusted internal angles (see Section 5.4.3),
 3. perform a **check** of the initial control line bearing using the last internal angle.
- d. for the network, calculate and adjust the coordinate misclose;
 1. the ΔE and ΔN coordinate differences from the adjusted bearings and mean **horizontal** distances,
 2. the **sum** of the ΔE s and ΔN s to calculate the **misclose** in ΔE and ΔN ,
 3. the misclose **corrections** in ΔE and ΔN , distributed by the **Bowditch** adjustment, (i.e., Section 5.4.3),
 4. the corrected ΔE s and ΔN s for the network,
 5. the adjusted coordinates of each control point from your initial control point coordinates,
 6. the misclose ratio calculated from the misclose vector and the sum of the network distances.

The angular misclose is distributed **evenly** between each of the internal angles. (Section 5.5.3)
 The **coordinate** misclose is distributed **in proportion** to the individual network **distances** (see Section 5.5.4).

5.5.3 Angular Misclose Correction

AT CEM_00	HAR				
Brg to BS 705A	47 51 53	Calculated BRG from CEM_00 to 705A			
∠BS to A	70 14 27	Mean angle at CEM_00 between BS and CEM_0A			
BRG 00 - A	118 06 20			118 06 20	Brg_00 - _0A
BRG A - 00				298 06 20	Back BRG
Mean observed angle		correction	Corr angle	Corr BRG	
∠A	98 27 40	+4	98 27 44		
BRG A - B				199 38 36	BRG_0A - _0B
BRG B - A				19 38 36	Back BRG
∠B	53 46 35	+3	53 46 38		
BRG B - 00				325 51 58	BRG_0B - _00
BRG 00 - B				145 51 58	Back BRG
∠00	27 45 35	+3	27 45 38		
BRG 00 - A				118 06 20	Check BRG_00 - _0A
SUM Obs angles	179 59 50	Too small, 10" has to be added to make 180°			
Correct Sum	180 00 00				
Misclose	-00 00 10				
Correction	+10"	Σ = +10"			

Note that the angular misclose (Figure 5.11) is distributed nearly evenly by integer values. Because of the way the figure has been traversed in a clockwise order (00 – A – B – 00), the adjusted angles are subtracted from individual back bearings. Traversing in the anticlockwise direction (00 – B – A – 00) would allow the adjusted angles to be added.

5.5.4 Adjusted Coordinates using the Bowditch Adjustment

The proportional coordinate adjustments in Easting and Northing are called **corrections** and have the opposite SIGN from the miscloses. Calculate a correction ratio or constant

$v = \left(\frac{-misclose}{\Sigma D} \right)$, which can be stored in memory. It can be retrieved easily and multiplied

by each traverse distance to calculate the adjustment $v_n = \left(\frac{-misclose}{\Sigma D} \right) d_n$. It helps avoid key-

stroke errors associated with the $v_n = \left(\frac{d_n}{\Sigma D} \right) - misclose$ method. Watch the SIGN of the corrections and make sure you have applied them correctly to the coordinate differences, including their sign.

Table 5-2 details the results of

1. Calculating unadjusted coordinate differences from **adjusted** bearing and observed mean horizontal distance. Sum of distances.
2. Summing unadjusted coordinate differences to find linear miscloses. Calculate misclose vector and ratio.
3. Distributing misclose as a **correction** to each set of unadjusted coordinates in proportion to individual traverse distances. Sum corrections equal negative misclose.
4. Summing unadjusted coordinates and corrections; ensure adjusted coordinates close.

Table 5-3 Bowditch adjustment to coordinate differences. Adjusted coordinates. Part d.

		Adjusted coordinates			E	N	Re-
CEM_00					354.303	7442.780	
	<i>Adj. BRG</i>	<i>H. DIST</i>	<i>dE</i>	<i>dN</i>			
00 - A	118 06 20	36.996	32.663	-17.429			
		<i>Correction</i>	0.004	-0.004			
CEM0_A	<i>Corrected dE & dN</i>		32.638	-17.443	386.491	7425.347	
A - B	199 38 36	21.365	-7.182	-20.122			
		<i>Correction</i>	0.003	-0.002			
CEM0_B	<i>Corrected dE & dN</i>		-7.180	-20.124	379.761	7405.223	
B - 00	325 51 58	45.380	-25.464	37.562			
		<i>Correction</i>	0.006	-0.006			
CEM_00	<i>Corrected dE & dN</i>		-25.458	37.557	354.303	7442.780	<i>check</i>
<i>Sum network distance</i>		103.741					
	<i>Misclose</i>	ΣdE & ΣdN	-0.013	0.012	<i>Sum of coordinate differences</i>		
<i>Corrections, v (nu)</i>		ΣvE & ΣvN	0.013	-0.012	<i>Sum of coordinate corrections</i>		
<i>Misclose vector dist</i>		0.017	<i>Direction</i>	313.3°			
<i>Misclose ration</i>		1:5947					
<i>Correction $\Sigma vE / \Sigma Dist$</i>		vE/m	1.223E-04				
<i>Correction $\Sigma vN / \Sigma Dist$</i>		vE/m	-1.154E-04				

Note that the coordinate misclose is distributed nearly proportionally to the traverse leg distances by integer values. The misclose in dE and dN is the difference between the finish and start coordinates. Without adjustment, the final coordinate values for CEM_0 would have been 354.290 and 7442.792. This shows that 0.013 (13 mm) would have to be **added** to the E coordinate and 0.012 (12 mm) **subtracted** from the N coordinate to close the figure.

5.5.5 Calculation of AREA by Coordinates Method

With the adjustment completed, the AREA of the figure is calculated by coordinate method (matrix determinant, see Section 3.4.7). Being triangular, a number of methods present themselves. These do not scale well to increased vertices (polygons) and in general the calculation of area by coordinates is used. Its downfall is that, apart from an independent re-calculation, there is no checking of the results. Being a triangle, there are **four** sets of coordinates in a closed figure as we return to the start point.

$$Area = \left| \frac{1}{2} \left(\sum_{i=1}^n (E_i N_{i+1} - E_{i+1} N_i) \right) \right|$$

It is realized by forming a matrix of coordinates and cross multiplying.

$$Area = \frac{1}{2}(E_1N_2 - E_2N_1 + E_2N_3 - E_3N_2 + E_3N_4 - E_4N_3),$$

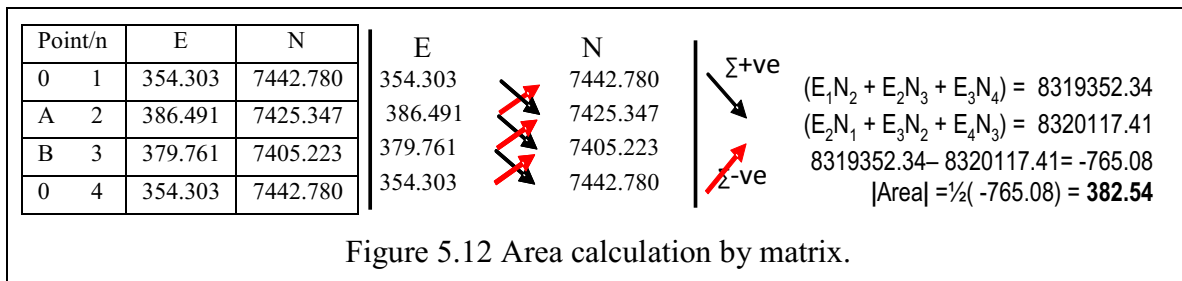

Figure 5.12 Area calculation by matrix.

AREA = 382.54

There is no independent way to check the results. Just a re-calculation.

5.5.6 Calculation of Area by Double Longitude Coordinates

The method of area by double longitude coordinates utilizes the general formula:

$$2Area = \sum_{p=1}^n (E_{p+1} - E_p)(N_p + N_{p+1}) \text{ where } (E_{p+1} - E_p) = \delta E \text{ and } (N_p + N_{p+1}) = \Sigma N$$

Check. $2Area = \sum_{p=1}^n (N_{p+1} - N_p)(E_p + E_{p+1}) \text{ where } (N_{p+1} - N_p) = \delta N \text{ and } (E_p + E_{p+1}) = \Sigma E$

Column	1	2	3	4	Inner	Outer	
Point/p	$E/\delta E^S$	$N/\delta N^S$	ΣE^S	ΣN^S	2 x 3	1 x 4	
0	1	354.303	7442.780				
Differences		32.188	-17.443	740.794	14868.127	-12914.26	478575.27
A	2	386.491	7425.347				
		-6.730	-20.124	766.252	14830.570	-15420.06	-99809.74
B	3	379.761	7405.223				
		-25.458	37.557	734.064	14848.003	27569.24	-378000.46
0	4	354.303	7442.780		2 Area =	-765.08	765.08
					Area =	382.54	

Once the Bowditch adjustment has been completed the adjusted coordinate differences in Easting and Northing are available for the double longitude calculation. The **sums** of the adjacent adjusted Eastings and Northings coordinates are tabulated in Table 5-4.

$$2Area = \sum_{p=1}^n (N_{p+1} - N_p)(E_p + E_{p+1}) \Rightarrow \sum_{p=1}^n (\delta N^S)(\Sigma E^S)$$

2A = sum inner products, columns 2 and 3

$$2Area = \sum_{p=1}^n (E_{p+1} - E_p)(N_p + N_{p+1}) \Rightarrow \sum_{p=1}^n (\delta E^S)(\Sigma N^S)$$

Check. 2A = sum outer products, columns 1 and 4

$$2A = (-17.443 \times 740.794) + (-20.124 \times 766.252) + (37.557 \times 734.064) = -765.075$$

Check calculation:

$$2A = (32.188 \times 14868.127) + (-6.730 \times 14830.570) + (-25.458 \times 14848.003) = 765.075$$

$$|Area| = \frac{1}{2}(765.075) = \mathbf{382.578}$$

The check calculations **must** produce the same result with a **different** sign.

This IS an independent way to check the results.

5.5.7 Example Field Calculations. Field Practical in Appendix A2-3

This example works with a typical extract from your field book. You have:

1. Oriented your TS by calculated bearing from CEM_0 to 705A and entered it in the TS using the HAR input. Figure 5.13 shows the calculation.

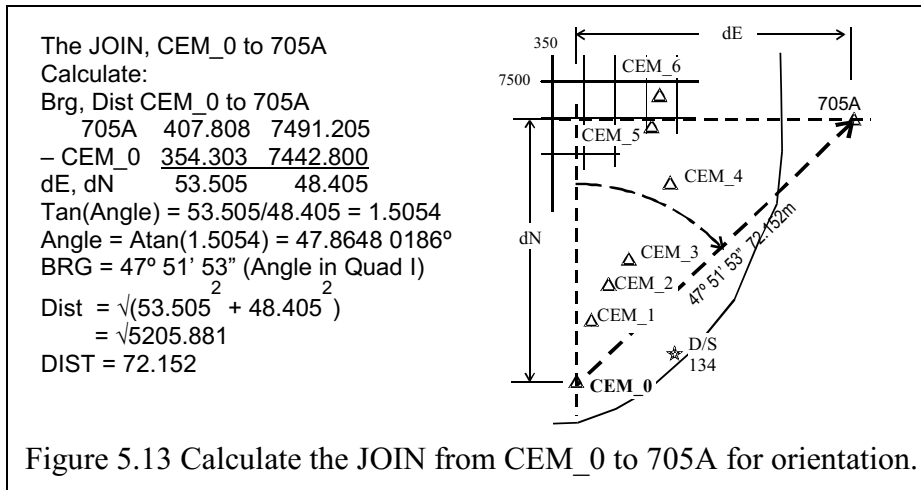

2. Observed a back sight (BS) bearing to a reference object (RO), in this case the SE corner of building 105, for direction only, to establish orientation for field practical 4.
3. Observed a bearing, zenith angle and slope distance to DH3 and grid 350E, 7500N. Join CEM_0 to 705A is the calculation of the bearing to set for the horizontal angle reading (HAR) in the Total Station (TS).

Table 5-5 Field book observations.

Total Station Observations			Task:		Obs.: JDW		Book-er: BC		Date: 21/08/14	
Control orientation, BS and pickup									Page: 1 / 5	
At STN:	CEM_0	HI = 1.545	Obs. set-up. PC-30 ppm 5							
STN	Face	HAR	VA/ZA	S dist	H	V	HT	RMK		
705A	L	47 51 53						Brg for site control		
SE 105	L	19 27 48						Dir only BS RO for control		
DH3	L	353 31 50	87 28 52	60.070			HI	Collar DH3. -3.2		
Grid	L	356 30 10	87 39 50	58.648			HI	350E, 7500		

4. Polar from CEM_0 to DH3 is the set of calculations used to find the coordinates of the bottom of DH3.
5. Use the data to calculate the reduced level (RL) of the grid intersection at 350E, 7500N.

Figure 5.14 shows the reduction of the FB data.

DH3; E347.54, N 7502.43, invert of hole, RL = 15.5m.

The OP coordinates of E350, N7500 have been calculated as E350.728, N7501.29. This now produces the conundrum of the status of the OP, which may be a lease boundary. Do you provide another control point at your E350, N7500 for future work? Or do you accept a shift of dE = 0.728m, dN=1.29m. Certainly, the OP should not be “shifted” to a new location. The situation may have to be adjudicated by a licenced surveyor if the post pertains to a lease boundary.

The POLAR, CEM_0 to DH3

At: CEM_0 354.303 7442.800 16.06

Calculate: Coordinates DH3 from FB

Brg CEM_0 to DH3: $353^{\circ} 31' 51''$

ZA CEM_0 to DH3: $87^{\circ} 28' 52''$

S CEM_0 to DH3: 60.070 (slope dist)

1. Find H dist & V dist from ZA and S

$$H = S \sin(ZA) = 60.07 \sin(87^{\circ} 28' 52'')$$

$$= 60.07 \times 0.99903 = 60.012$$

$$V = S \cos(ZA) = 60.070 \cos(87^{\circ} 28' 52'')$$

$$= 60.070 \times 0.04395 = 2.640$$

2. Find dE & dN from Brg & H distance

$$dE = H \sin(\text{Brg}) = 60.012 \sin(353^{\circ} 31' 51'')$$

$$= 60.012 \times -0.11267 = -6.762$$

$$dN = H \cos(\text{Brg}) = 60.012 \cos(351^{\circ} 31' 51'')$$

$$= 60.012 \times 0.99363 = 59.630$$

The POLAR, CEM_0 to DH3

At: CEM_0 354.303 7442.800 16.06

3. Find E & N of DH3 from dE & dN

$$E_{\text{DH3}} = E_{\text{CEM}_0} + dE$$

$$= 354.303 + (-6.762) = 347.54$$

$$N_{\text{DH3}} = N_{\text{CEM}_0} + dN$$

$$= 7442.800 + 59.630 = 7502.43$$

4. Find RL & seam level at DH3

$$RL_{\text{DH3}} = RL_{\text{CEM}_0} + V \text{ (HT = HI)}$$

$$= 16.06 + 2.64 = 18.70$$

5. Find RL seam from RL_{DH3} + depth

$$RL \text{ seam} = RL_{\text{DH3}} + \text{depth}$$

$$= 18.7 - 3.2 = 15.5$$

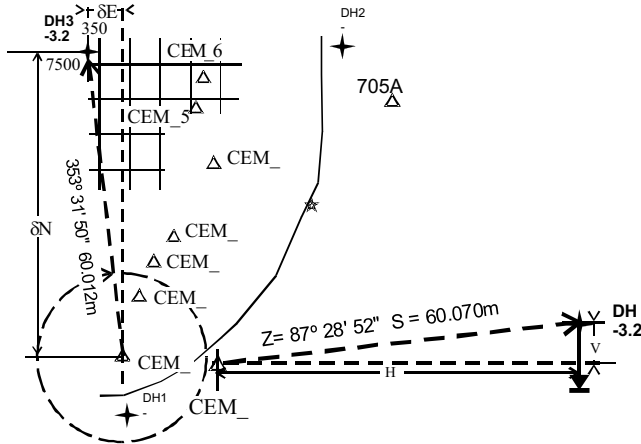

6. Similarly, CEM_0 to 350,7500

At: CEM_0 354.303 7442.800 16.06

$$H = S \sin(ZA) = 58.648 \sin(87^{\circ} 39' 50'')$$

$$= 58.600$$

$$S = S \cos(ZA) = 58.648 \cos(87^{\circ} 39' 50'')$$

$$= 2.390$$

$$dE = H \sin(\text{Brg}) = 58.6 \sin(356^{\circ} 30' 10'')$$

$$= -3.574$$

$$dN = H \cos(\text{Brg}) = 58.6 \cos(356^{\circ} 30' 10'')$$

$$= 58.490$$

$$E = 354.303 + (-3.574) = 350.728$$

$$N = 7442.8 + 58.49 = 7501.29$$

$$RL = 16.06 + 2.39 = 18.45$$

Figure 5.14 Reduction of FB observations to DH3 and 350E, 7500N.

5.5.8 The “ecy” Station. Missing the Point?

Sometimes observations cannot be made from the required control station. Occupancy may be denied by access considerations, other users etc. There are a number of ways to overcome the problem. It all depends on the station geometry and the measurements you can take. At any **eccentric** station, take as many observations as you can to the control station.

The bearing from the control station, CEM_0, to the RO (Back Sight) is known from a previous observation session, as well as the calculated bearing and distance to control station, 705A. On the next visit CEM_0 is visible, but can't be occupied.

An eccentric station, EC_0, is established where CEM_0 and 705A are visible.

The following example illustrates the method of determining the bearing to a Reference Object (RO) given the following observations at the eccentric station EC_0:

The best method is to point to CEM_0 and set $0^{\circ} 00' 00''$ on TS (0 SET), angle can be read directly from the machine.

Angles, $\angle RO$ and $\angle E$, between the known station, CEM_0, the RO and 705A.

$$\angle \delta RO = \angle E - \angle RO$$

Distance, a , from eccentric to known station (CEM_0 to EC_0) has been measured.

Careful taping will do.

The objects of the exercise are to find, by applying the Sin rule: $a/\sin A = b/\sin B = c/\sin C$ for angles and sides:

1. Coordinates of eccentric station,
2. Bearing from eccentric station to RO.

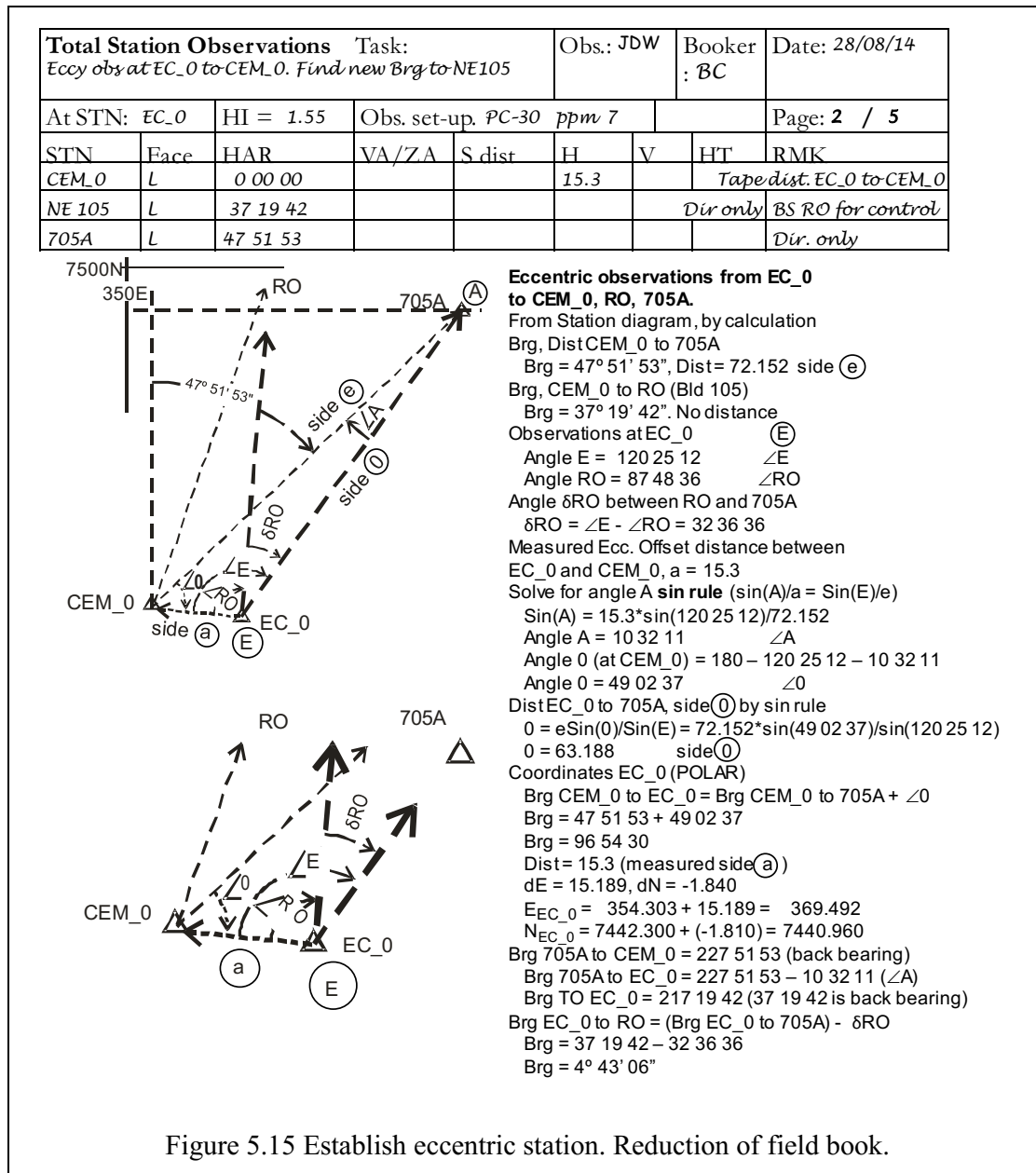

Figure 5.15 Establish eccentric station. Reduction of field book.

In this example the offset distance, 15.3 m, is far too large. But it allows a scaled graphic to be presented.

Instead let side **a** = 2.5 m and leave the angles as above. By Sin rule for angles and sides:

Angle A = 1° 42' 55" (2.5 x sin(120 25 12) / 72.152 = 0.02988 = 1.7122°)

Angle 0 = 57° 51' 53" (180 - 120 25 12 - 1 42 55)

Side 0 = 70.852m

Coordinates EC_0

Brg CEM_0 to EC_0 = Brg 705A + ∠0 = 47 51 53 + 57 51 53

Brg = 105 43 46

Dist, **a**, = 2.5. Then, by POLAR calculation:

dE = 2.406, dN = -0.678

E_{EC_0} = 354.303 + 2.406 = 56.709

N_{EC_0} = 7442.800 + (-0.678) = 7442.122

Brg 705A to EC_0 = Back bearing - $\angle A = 227\ 51\ 53 - 1\ 42\ 55$

Brg = 226 08 58. Reverse bearing EC_0 to 705A = 46 08 58

Brg EC_0 to RO = 46 08 58 – 32 36 36 (Brg EC_0 to 705A – δ RO)

Brg = 13° 32' 22". This can be compared with the original Brg of 19° 27' 28".

You now have an orientation from the eccentric station to the RO in the original coordinate system.

5.6 Sources of Errors in Traversing

- Mistakes and systematic errors in taping.
- Inaccurate centring of the Total Station or prism affecting the distances.
- Total Station not level or not in adjustment
- Incorrect use of the Total Station
- For manual recording, mistakes in reading and booking.

5.7 Concluding Remarks

This chapter has presented you with the method employed by surveyors to determine horizontal positions of points (Eastings and Northings). In your professional work, you will more often be dealing with positions of points. Understanding how they are obtained is therefore the first step to properly constrain your structures in their absolute and relative positions. For mining students, knowing the correct positions of points can be crucial for several tasks that include, e.g., rescue missions. In summary, therefore, positions are derived from measured angles and distances which have to be corrected and adjusted due to the presence of random errors. It is the finally adjusted coordinates (Eastings and Northings) that are used for setting out of structures.

5.8 Reference for Chapter 5

1. Irvine and Maclellan (2006) Surveying for Construction. Fifth edition, McGraw, Chaps. 5 and 6
2. Schofield and Breach (2007) Engineering Surveying. Sixth edition, Elsevier, Chap. 3
3. Uren J, Price WF (2010) Surveying for Engineers. Palgrave Macmillan Ltd. pp. 816.

Chapter 6 Total Station Differential Levelling

6.1 Introductory Remarks

Total Station differential levelling (also known as trigonometric heighting) is a variant of conventional differential levelling. Differences in height can be determined by making a series of zenith angle and slope distance observations to a prism mounted on a fixed height pole. This technique is conducted in the same fashion as conventional two-way differential levelling.

The Intergovernmental Committee on Surveying and Mapping (ICSM) through its Special Publication 1, Version 2.0 (2013) provides guidelines for Total Station Differential Levelling to achieve various levels of misclosure.

Allowable misclose: When conducting differential levelling or Total Station differential levelling, errors propagate in proportion to the square root of the travelled distance. A misclose assessment should be undertaken to verify that forward and backward runs of a levelling traverse, including any individual bays, are within the maximum allowable misclose.

The allowable misclose is calculated using the formula $r_{mm} = n\sqrt{k}$ (k in km). Three standards, using empirical values, are recommended: $2\text{mm}\sqrt{k}$, $6\text{mm}\sqrt{k}$ and $12\text{mm}\sqrt{k}$

For the recommended maximum allowable misclosure of $12\sqrt{k}$ (forward and back).

Equipment: An EDM Total Station; distance $\pm 3\text{mm} + 2\text{ppm}$, zenith angle $5''$, daily calibration of index errors of vertical circle and level compensator, compensator accuracy $2.5''$, atmospheric measurement accurate to $t = 1^\circ\text{C}$, $P = 1\text{ Hpa}$, $\text{RH} = 2\%$. N/A to $12\sqrt{k}$ levelling, telescopic tripod fixed height reflector with bi-pod support; staff bubble attached and accurate to $10'$ verticality, fixed height ensured; permanently mounted, balanced and tilting prism, general prism; standard change plate.

Observation techniques: Two-way levelling; avoid fixed rod index error, observer same rod on first BS/last FS; total distance foresight approx. equal to backsight; F/L, F/R rounds of observations, 3; height difference readings to 1mm; atmospheric conditions N/A; maximum sight length 120m; minimum ground clearance 0.5m.

Check the specifications of your Total Station to ensure it meets these requirements.

6.2 Errors Propagation in Trigonometric Levelling

Compared with differential levelling, where we are concerned generally only with a horizontal plane through the level, trigonometric levelling involves extra sources of systematic and random errors.

The difference in height between instrument and target, reading the elevation angle, α , and the slope distance, S , is:

$$\Delta h = S \sin \alpha$$

however the Total Station reading for vertical angle is generally expressed as the **zenith angle, z** , where the direction to the zenith is 0° , and the horizon is 90° . The formula then becomes:

$$\Delta h = S \cos z.$$

The resultant Δh has the correct elevation or depression sign.

The complete Δh between two ground points has to incorporate the height of both the instrument (h_i) and the target (h_t), and the correction for curvature and refraction (h_{CR}). This was discussed in differential levelling, given:

$$h_{CR} = CR \left(\frac{D}{1000} \right)^2 \text{ where } CR = 0.0675 \text{ for distance } D \text{ in metres, and } D = S \sin z.$$

Thus:
$$\Delta h = h_i + S \cos z + CR \left(\frac{S \sin z}{1000} \right)^2 - h_t.$$

Trigonometric levelling is achieved by measuring the elevation angle between the Total Station and the target, and measuring the slope distance to the target.

The sources of error include:

- digital reading accuracy, (DIN 18723, ISO 17123)
- Vertical automatic compensator error,
- distance reading accuracy, the slope distance, S
- set-up accuracy over the measuring point and target point (centring accuracy),
- accuracy of height of instrument (h_i) and target (h_t).

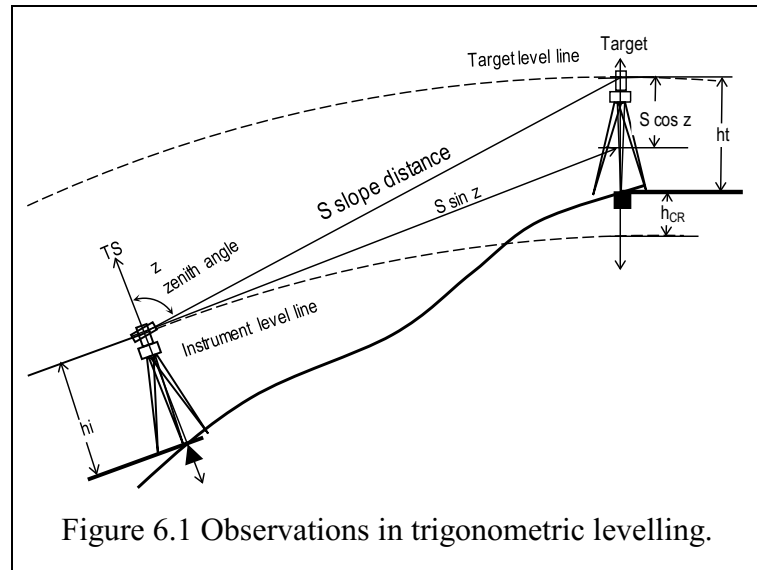

Figure 6.1 Observations in trigonometric levelling.

Continuing the analytical discussion of errors in levelling,

- Ghilani 2010,
 - *Error propagation in trigonometric levelling*, chapter 9.4, pp159 et seq.

As with any set of measurement observations, trigonometric levelling is subject to three types of errors:

- Systematic errors,
- Random errors, and
- Blunders or mistakes.

6.2.1 Systematic Errors in Level Observations

1. Vertical circle collimation errors,
 - minimised by taking the mean of Face Left (FL) and Face Right (FR) zenith angle readings to target,
2. Earth curvature and refraction, h_{CR} , corrected by:

$$h_{CR} = CR \left(\frac{D}{1000} \right)^2 \text{ where } CR = 0.0675 \text{ for distance } D \text{ in metres.}$$

The effect is minimal over typical lines of say $D = S \sin z = 100$, for example: (Ghilani 2010, p153)

$$h_{CR} = 0.0007\text{m (0.7mm)}$$

3. Deviation from instrument manufacturer's standard atmosphere for distance measurement.

The slope distance is used to calculate the difference in height, Δh

- the velocity of light (the distance measuring method) varies with air density.
- causes errors in distance reading.

Deviations from the standard atmosphere by local meteorological conditions introduces a correction, expressed in parts per million (ppm) of slope distance. At higher elevations, local pressure is significantly lower than sea level pressure.

Within acceptable limits atmospheric pressure decreases at the rate of about 1hPa per 9m of altitude.

Correction (ppm) from manufacturer's standard atmosphere. Sokkia SET530 series.

Instruments calibration standard atmosphere: temperature 15°C, (Leica 12°C) local pressure 1013.25hPa, (Leica 1012hPa)	deviations are of the order of: ² 1ppm/°C 1ppm/3.6hPa, pressure drops approx. 1hPa/9m altitude. 1ppm/32m altitude 0.1ppm/10% change in RH, insignificant.
RH 0%.	

At Newman, altitude 550m, MSL pressure 1010, temp 35°C the station pressure is about $1010 - (550/9) = 949\text{hPa}$

$$\begin{aligned} \text{ppm correction} &= +20 \text{ for temperature } (35 - 25) \text{ and} \\ &= +18 \text{ for pressure } (1013-949)/3.6 \\ &= +38\text{ppm} \end{aligned}$$

which means that, unless the meteorological conditions are dialled into the instrument, there is a slope distance error of 0.004m (4mm) over 100m distance.

4. Incorrect scale factor (S.F.) dialled or programmed into instrument computer.
 - only affects displayed horizontal distance,
 - record slope distance and zenith angle
 - check and note scale factor setting, or change to S.F = 1 in field book.

6.2.2 Random Errors in Observations

1. Digital reading accuracy, the ability to define the accuracy of pointing to the target
 - specified by the manufacturer, the Sokkia SET530RK3 has a pointing accuracy of $\pm 5''$
 - in accordance with DIN 18723, ISO 17123
2. Sighting and pointing errors to the target. Errors will tend to be random, and are affected by parallax error in focussing the eyepiece and the object pointing to the centre of the prism, instead of intersecting the target plate.
3. EDM errors,
 - considering coincidence of measuring point with vertical axis,
 - errors in distance calculation (oscillator errors)
 - errors associated with target; prism, flat plate, reflectorless
 - varies, $\pm 2\text{mm} \pm 2\text{ppm}$ to a prism to $\pm 10\text{mm} \pm 2\text{ppm}$ for reflectorless readings.
4. Centring errors, the ability to centre over a point. Figure 6.3. This error may be introduced by:
 - non-perpendicular optical plummet,
 - check misalignment of plummet by 90° observations through plummet to ground point,
 - imprecise centring of reticule point. In order of 2 – 5mm.
5. Measurement of height of instrument trunnion axis and target trunnion axis, Figure 6.4, probably of the order of $\pm 5\text{mm}$.

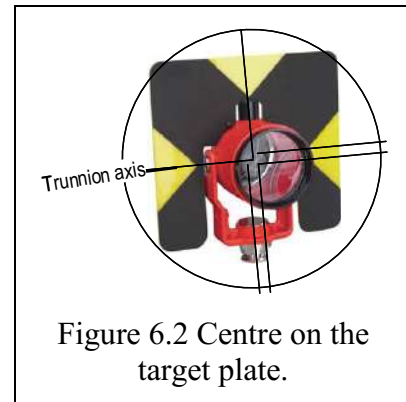

Figure 6.2 Centre on the target plate.

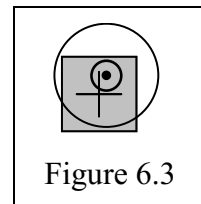

Figure 6.3

² Rüeger, J.M., Introduction to Electronic Distance Measurement, School of Surveying, UNSW, 1984

Recalling that $\Delta h = h_i + S \cos z + CR \left(\frac{S \sin z}{1000} \right)^2 - h_t$

where $CR = 0.0675$

the standard error of the Δh observation, combining partial derivatives (Ghilani 2010, p160), is:

$$\sigma_{\Delta h} = \pm \sqrt{\sigma_{h_i}^2 + \sigma_{h_t}^2 + \left[\left(\cos z + \frac{CR(S) \sin^2 z}{500,000} \right) \sigma_s \right]^2 + \left[\left(\frac{CR(S) \sin z \cos z}{500,000} - S \sin z \right) \frac{\sigma_z}{206265} \right]^2}$$

For example, where $h_t = h_i$, $\sigma_{h_t/h_i} = \pm 0.005$ and $z = 88^\circ \pm 5''$, $S = 150 \pm 0.01m$

$\Delta h = 5.235m$

$\sigma_{\Delta h} = \pm 0.008.$

However, analysis of the observations shows that the contribution of the error in measuring instrument and target height, $\sigma_{h_t/h_i} = \pm 0.005m$, contributes $\pm 0.0071m$ while the TS contributes $\pm 0.0036m$ to the error budget. (They combine to produce $\sigma_{\Delta h} = \pm 0.008.$)



Figure 6.4 Trunnion

6.3 Calculation of Three Dimensional Coordinates from Observations

Capture of points for a digital elevation model (DEM). “Intersection by distances.”

There are two calculation tasks to be carried out from your observations:

1. Calculation of observation point coordinates including:
 - 3D coordinates
 - orientation of backsights
 - check calculations
2. Calculation of data point coordinates taken from the observation point:
 - 3D coordinates.

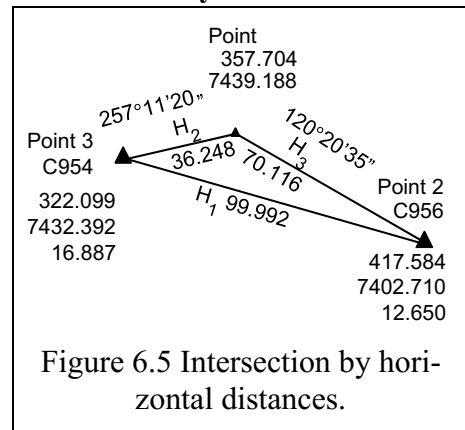

Figure 6.5 Intersection by horizontal distances.

6.3.1 Calculation of Observed Distances.

Two methods are available, both of which rely on the reduction of the observed **slope distance, S**, into its **horizontal distance, H**, and **vertical distance, V**, components.

H and V are the rectangular coordinates of the polar vector r, θ

$r =$ slope distance, **S**

$\theta =$ zenith angle, **Z**.

$H = S \sin Z$

$V = S \cos Z,$ with the correct **sign** for elevation difference between observation point and target.

Remember: The zenith angle, Z, is from the ZENITH (Figure 4.1(b)) and is at 90° when horizontal. DO NOT try to calculate angles of elevation or depression. Too risky.

6.3.2 Direct Calculation of Horizontal X, Y Coordinates by Intersection of Horizontal Distances to Known Points

The method relies on measuring horizontal distances from the unknown point to two known control points. It is analogous to finding the point of intersection of the radii from the two known points. The horizontal distance between the two controls is calculated by the JOIN method, it also provides the bearing from one point to another. See Figures 6.5 and 6.6.

Two other distances are required: the **perpendicular distance, h**, from the known base line to the apex of the triangle (the “height” of the triangle); the **projected distance, p**, along the base line to the perpendicular intersection point.

H_1 is calculated, H_2 and H_3 are measured from Point 1. Note that the distances are **opposite** their respective control points.

To conform with survey convention, we re-label the coordinate frame as E (east) and N (north). Direction from 0° is a clockwise rotation through to 360° . Again, it is a polar to rectangular conversion with:

$$\begin{aligned} r &\text{ indicating horizontal distance, } H \\ \theta &\text{ indicating direction and} \\ E &= H \sin \theta \\ N &= H \cos \theta. \end{aligned}$$

With intersection point 1 label the two known points in **clockwise** order as 2 and 3. (See Figure 6.6).

Solve the coordinates of point 1 directly by the formulae:

$$\begin{aligned} E_1 &= E_2 + p \sin \theta_{23} \pm h \cos \theta_{23} && \text{Point 1 right/left line 2-3: use } \pm \text{ (+ or -)} \\ N_1 &= N_2 + p \cos \theta_{23} \mp h \sin \theta_{23} && \text{Point 1 right/left line 2-3: use } \mp \text{ (- or +).} \end{aligned}$$

An alternate method, avoiding bearings calculations.

It may be more convenient to use a coordinate difference form rather than the bearing from 2 to 3. The modern scientific calculator makes this step redundant, however the problem can be solved with a four function plus $\sqrt{\quad}$ calculator. It may be more convenient on your HP10s calculator. It also guards against input errors, and problems determining the bearing.

1. Calculate the POLAR between 2 and 3. (Bearing 2-3 and distance).

$$E_3 - E_2 = \text{opposite side;}$$

$$N_3 - N_2 = \text{adjacent side;}$$

H_1 is the hypotenuse found by Pythagoras. It is the side **opposite** point 1.

$$H_1 = \sqrt{(E_3 - E_2)^2 + (N_3 - N_2)^2}$$

The **Sin** θ_{23} and **Cos** θ_{23} can found directly from coordinate differences:

$$a = \frac{E_3 - E_2}{H_1} \text{ Calculating Sin } \theta_{23} \text{ directly where}$$

$$(E_3 - E_2) = \text{opposite side, } H_1 = \text{hypotenuse}$$

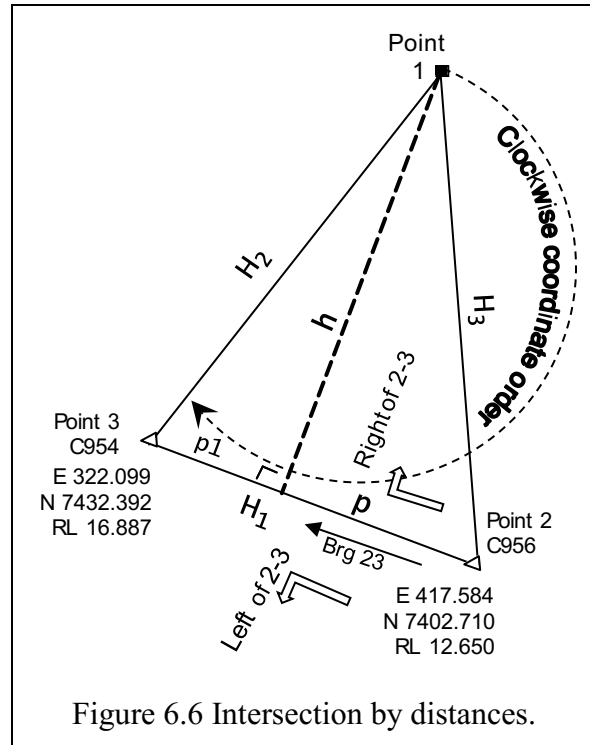

Figure 6.6 Intersection by distances.

$$b = \frac{N_3 - N_2}{H_1} \text{ Calculating Cos } \theta_{23} \text{ directly where}$$

(N₃ - N₂) = adjacent side, H₁ = hypotenuse

- Calculate the horizontal distances from measured slope distance:

$$H_2 = S_{13} \text{ Sin } Z_{13}$$

$$H_3 = S_{12} \text{ Sin } Z_{12}$$

$$\text{calculate } p = \frac{H_1^2 + H_3^2 - H_2^2}{2H_1} \text{ (H}_2, H_3 \text{ already measured and calculated.)}$$

$$\text{and } h = \sqrt{H_3^2 - p^2}$$

- We know, from the POLAR, that E₁ = E₂ + dE₂₁ and N₁ = N₂ + dN₂₁

$$E_1 = E_2 + p \frac{E_3 - E_2}{H_1} \pm h \frac{N_3 - N_2}{H_1} \text{ (dE}_{21} = p \frac{E_3 - E_2}{H_1} \pm h \frac{N_3 - N_2}{H_1})$$

$$N_1 = N_2 + p \frac{N_3 - N_2}{H_1} \mp h \frac{E_3 - E_2}{H_1} \text{ (dN}_{21} = p \frac{N_3 - N_2}{H_1} \mp h \frac{E_3 - E_2}{H_1}).$$

- Then, by specifying that the coordinate points are in clockwise order,

1 is to the **right** of **line 2 – 3** Figure 6.6 the intersection by distance solution becomes:

$$\boxed{E_1 = E_2 + ap + bh} \text{ 1 is to the right of line 2 – 3}$$

$$\boxed{N_1 = N_2 + bp - ah} \text{ 1 is to the right of line 2 – 3}$$

- Calculate bearings from point 1 to points 2 and 3 to provide orientation and checks:

$$\text{Bearing 1 to 2: } \theta_{12} = ATAN\left(\frac{\Delta E_{12}}{\Delta N_{12}}\right) = ATAN\left(\frac{E_2 - E_1}{N_2 - N_1}\right) \text{ in correct quadrant}$$

$$\text{Bearing 1 to 3: } \theta_{13} = ATAN\left(\frac{\Delta E_{13}}{\Delta N_{13}}\right) = ATAN\left(\frac{E_3 - E_1}{N_3 - N_1}\right) \text{ in correct quadrant}$$

Sample calculation sheet from field book data:

Table 6-1 Observations for intersection distances.								
At STN 1001							HI	1.535
To STN	Face	HAR	VA (Z)	S dist	H = S sin Z	V = S Cos Z		
C956	L	120 20 30	92 30 30	70.184			HT 1.598	
Mean Dirn		120 20 35	92 30 25	70.183	70.116	-3.070		
C956	R	300 20 40	267 29 40	70.182				
Mean angle		137 50 45						
C954	L	258 11 20	87 55 10	36.272			HT 1.750	
Mean Dirn		258 11 20	87 55 20	36.272	36.248	1.315		
C954	R	78 11 40	272 04 30	36.272				

- Enumerate data set and calculate parameters:

From supplied data:

$\Delta E_{23} = E_3 - E_2 = -95.485$	$\Delta N_{23} = N_3 - N_2 = 29.682$
$H_1 = H_{23} = \sqrt{(\Delta E_{23})^2 + (\Delta N_{23})^2} = 99.992$	from calculated join 2 – 3, Pythagoras
$H_2 = H_{13} = 36.248$	from reduction of slope distance
$H_3 = H_{12} = 70.116$	from reduction of slope distance
$a = \Delta E_{23}/H_1 = -0.95493$	$b = \Delta N_{23}/H_1 = 0.29684$
$p = (H_3^2 + H_1^2 - H_2^2)/(2H_1) = 68.0091$	$h = \sqrt{(H_3^2 - p^2)} = 17.0591$

2. Calculate coordinates of STN 1:

$$\begin{aligned} E_1 &= E_2 + ap + bh = \mathbf{357.704} && \text{note + sign} \\ N_1 &= N_2 + bp - ah = \mathbf{7439.188} && \text{note - sign} \end{aligned}$$

3. Calculate RL STN 1001 and check:

(Back from RLs 2 & 3) Figure 6.7.

$$\begin{aligned} RL_1 &= RL_2 - V_{21} + HT_2 - HI \\ &= 12.650 - (-3.070) + 1.598 - 1.535 \\ &= \mathbf{15.783} \end{aligned}$$

$$\begin{aligned} RL_1 &= RL_3 - V_{31} + HT_3 - HI \\ &= 16.887 - (+1.315) + 1.750 - 1.535 \\ &= \mathbf{15.787} \checkmark \end{aligned}$$

$$\text{Mean } RL_1 = \mathbf{15.785}$$

4. Calculate BRG₁₂ and BRG₁₃

$$\begin{aligned} \theta_{12} &= \text{ATAN} \left(\frac{E_2 - E_1}{N_2 - N_1} \right) \text{ in correct quadrant} \\ &= \text{ATAN}(-1.64152) \\ &= -58.65059 + 180 \text{ (quadrant 2)} = 121.34941 \\ &= \mathbf{121^\circ 20' 58''} \end{aligned}$$

$$\begin{aligned} \theta_{13} &= \text{ATAN} \left(\frac{E_3 - E_1}{N_3 - N_1} \right) \text{ in correct quadrant} \\ &= \text{ATAN}(5.238931) \\ &= 79.193453 + 180 \text{ (quadrant 3)} = 259.193453 \\ &= \mathbf{259^\circ 11' 36''} \end{aligned}$$

5. Calculate angle between BRG₁₂ and BRG₁₃ and check with mean observed angle.

$$= 259^\circ 11' 36'' - 121^\circ 20' 58''$$

$$\text{Calculated angle} = 137^\circ 50' 39''$$

From field sheet:

$$\text{Mean angle} = 137^\circ 50' 45'' \checkmark \text{ (6'' difference over 70m = 0.002m (2mm))}$$

6. Summarize data:

STN 1001	C956	C954
E 357.704	E 417.584	N 322.099
N 7439.188	N 7402.710	N 7432.392
RL 15.785	RL 12.650	RL 16.887
HAR ₁₂ 120° 20' 35" Mean direction (FL/FR) to C956		
BRG ₁₂ 121° 20' 58" BRG to C956. Rotation angle from mean direction +1° 00' 23"		
BRG ₁₃ 259° 11' 36" BRG to C954.		

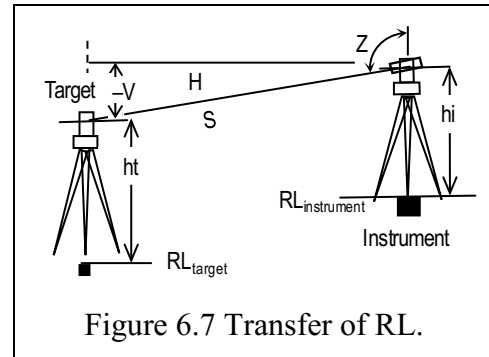

Figure 6.7 Transfer of RL.

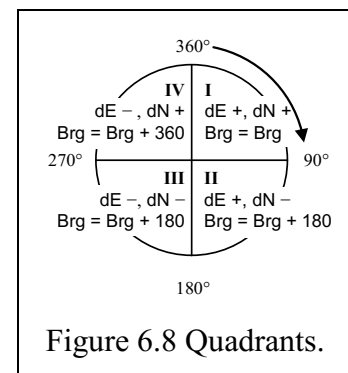

Figure 6.8 Quadrants.

6.3.3 Orientation of a Local Coordinate System to a Grid System

1. Initial orientation of directions was by alignment to true north using a tube (trough) compass to define magnetic north. The Total Station horizontal circle was locked and the true direction of magnetic north was entered into the Total Station after allowance was made for magnetic variation (deviation).
2. Once the coordinates of the new control point are determined, the calculated TRUE BEARING is compared to an observed control point bearing and the rotation angle determined. **+1° 00' 23"**
3. The initial BS bearing can be corrected to give a true bearing for future observations.

6.3.4 Observation, Booking and Calculation of Terrain Points for DTM

1. Aim at your back sight on FL.

In this case to STN 2, C956 has a BRG of $121^{\circ} 20' 58''$

Set the calculated bearing on the Total Station using **H.ANG**

Set the prism on a prism pole and adjust HT to the same height as the HI.

Observe and book on FL to significant points, as illustrated in a booking sheet

Calculate the horizontal distance, H and the vertical distance, V, to each point.

see Table 6-2.

Table 6-2 DEM observations.

At STN 1001		Calculate horizontal, H, and vertical, V, distances				RL 15.785	HI	1.535
To	Face	HAR	VA (Z)	S dist	H = S sinZ	V = S cosZ		
2, C956	L	121 20 58	92 33 36	70.186	70.116	-3.135	HT	1.598
NE Corner 204		143 35 09	93 50 00	50.327	50.215	-3.364	HT	HI
N face 204		154 30 50	94 19 33	44.876	44.748	-3.385		
CH 00		155 31 20	95 40 55	39.747	39.552	-3.395		
705, CH93.3		44 52 37	91 14 30	71.903	71.886	-1.558		
Path P1		34 59 41	90 22 45	88.404	88.402	-0.585		
P2		52 55 07	90 33 14	61.550	61.547	-0.595		
P3		76 07 40	91 07 11	31.470	31.464	-0.615		
S Valve 1								
Tree T1 dia 0.4								

2. Reduction of observations to coordinates

E station point = E STN 1 + dE (= H Sin(HAR))

N station point = N STN 1 + dN (= H Cos(HAR))

RL station point = RL STN 1 + V + HI - HT note that if HT = HI then

RL of point = RL STN 1 + V, see Table 6-3.

Table 6-3 Reduction of observations.

At STN 1001	Radiate from 1001		357.704	7439.188	15.785		Calc
To STN	dE	dN	E	N	V	RL	
2, C956	59.880	-36.478	417.584	7402.711	-3.135	12.587	Check
Cnr 204	29.808	-40.410	387.513	7398.778	-3.364	12.412	
N Face 204	19.225	-40.393	376.959	7398.795	-3.385	12.400	
CH00	16.388	-35.997	374.092	7403.191	-3.935	11.850	
705, CH93.3	50.722	50.594	408.426	7490.129	-1.558	14.230	
Path P1	50.699	72.420	408.426	7511.608	-0.585	15.200	
P2	49.101	37.110	406.805	7476.298	-0.595	15.190	
P3	30.546	7.544	388.250	7446.732	-0.615	15.170	
S Valve 1							
Tree T1 dia 0.4							

6.3.5 Feature Codes for Point and Line Pickup

In general, a **feature** is either a **point** or be part of a **line** or **polygon** (a closing line). Prefixing a feature with a symbol can be used to tell processing software how to display and process the collected data.

A **point** indicator is generally a plus sign, +.

A **line** indicator could be a slash mark, /.

Polygon indicators would depend on the specific software.

During the survey data collection process it is necessary to provide a description of each feature. This description is generally a short letter code or a numeric code which is associated with the feature. Codes are generally grouped around specific activities from which a particular code may be chosen.

Many integrated survey packages have suggested codes. Survey companies may have specific codes to be used with data pickup. These codes are often held in either the Total Station itself, or in an external data recorder attached to the Total Station.

Codes should be simple and easy to remember. Often they are an acronym of the full name. Whether a feature is a point, or part of a line.

Data collection for this field practical will be recorded on a feature pickup sheet attached to Field Practical 3. Use the To STN column to record sequential observation numbers. The Remarks column can be used to record the feature code.

Some suggested codes are listed:

Nr	CODE	Description	Nr	CODE	Description	Nr	CODE	Description
1	PM	Perm survey mark	160	DH	Drill hole	411	EP	Edge path
2	BM	Bench mark	170	WROW	Windrow	512	CABL	Cable pit
4	STN	Instrument station				609	RET	Retaining wall
5	SM	Survey mark	201	TREE	Tree >2m	713	ELP	Electric pole with light
101	CONT	Contour	204	SHRB	Shrub <5m	716	EPIT	Electricity pit
102	TOP	Top cut/fill	401	CB	Centre bitumen road	741	SPIT	Sewerage pit
103	TOE	Toe cut/fill	403	EB	Edge bitumen road	751	SV	Stop valve
104	ES	Existing surface	407	INV	Invert kerb/channel	762	UPIT	Unclassified pit
150	GRID	Grid intersection	410	PATH	Pedestrian path	851	TXT1	Text 1

Table 6-4 Sample feature codes.

6.4 Concluding remarks

This Chapter presented an alternative method to height determination that was covered in Chapter 2 (i.e., spirit levelling). In trigonometric heighting, abbreviated trig heighting, rather than using a level as we saw in Chapter 2, a total station is used instead. Whereas in Chapter 2 the spirit levelling measured height differences, trig heighting presented in this chapter measures angles and slope distances, which are then subjected to the traditional “sine” “tangent” and “cosine” formulae to derive the heights, hence its name trigonometric heighting. The advantages of trig heighting are rapidness in generating heights and the low cost involved. For various engineering tasks that require rapid generation relief, e.g., during reconnaissance for planning purposes, the method is handy. Moreover, with the current use of robotic total station that once set automatically tracks the target, spot heights and random heights of points of interest can be obtained. The disadvantage with the method is the low accuracy compared to the spirit levelling, which makes it unsuitable for use in obtaining vertical controls.

6.5 Reference to Chapter 6

1. Ghilani, C., Adjustment Computations Spatial Data Analysis, Wiley, 2010, 5th ed
2. Rüeger, J.M., Introduction to Electronic Distance Measurement, School of Surveying, UNSW, 1984

Chapter 7 Strike And Dip to an Embedded Plane

7.1 Introductory Remarks

Mining engineers are involved in the extraction of minerals from ore bodies that often incorporate deposition seams.

Civil engineers may also need an understanding of slopes associated with earth-works on sloping terrain. Typical use could be on bulk earth structures such as water reservoir dam walls, tank bunds and the like.

The ability to calculate depths and directions of drill holes, the slopes of drives and the calculation of inclined angles is not well covered in most surveying texts. This chapter attempts to show some of the simple calculation techniques available for use in the field, or as an adjunct to normal mine planning software. Field measurement of strike and dip of an exposed seam can be made using Total Stations, automatic levels or geologists' compasses, e.g, the Brunton type.

7.2 Strike and Dip

Geologists describe the orientation of a seam of mineralisation in terms of the direction of the horizontal plane intersecting the seam, the **strike**, and the maximum inclination of the plane, the **dip**. Exploratory drilling will intersect different geological structures, some of which may warrant development into a mine. Having located the seam, we now need to describe its location and orientation so that a mine may be planned to expose the seam.

7.3 Strike and Dip to a Plane

The relationship between the ground surface and the inferred seam, defined by three drill holes, DH0, DH1, and DH2, is illustrated in Figure 7.1.

Plane P_0, P_1, P_2, P_3 is the **horizontal** plane surface through S_0 , (below DH1) which is the "highest" intersect point.

The **dipping** plane, the intersected seam, is defined below the surface of points DH0, DH1 and DH2 at S_0, S_1 , and S_2 .

The line S_{strike} to S_3 defines the direction, as yet unknown, of the **strike line**.

The lines $S_0 - S_1$, and $S_0 - S_2$ are the **apparent** strike lines from S_0 .

The **true, or maximum**, dip from S_0 (DIP_{true}) is perpendicular to the strike line. So, if you find the direction of maximum dip; then you have defined the strike direction.

7.4 Deriving Strike and Dip of a Plane

The dipping plane is represented by the plane $apbdra$ containing S_0, S_1 , and S_2 in Figure 7.2. $rcqbdr$ is the plane containing S_1 and S_2 at a depth ac below S_0 . Angles at c and q are right angles.

There are 4 angles to consider:

1. The **true** dip, θ_{max} (theta), is the slope ad where $ac = rise$ and $cd = run$.
2. The **apparent** dip from a (S_0) to b at S_2 (θ_2)

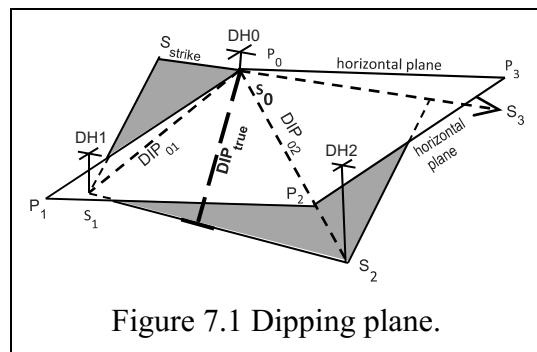

Figure 7.1 Dipping plane.

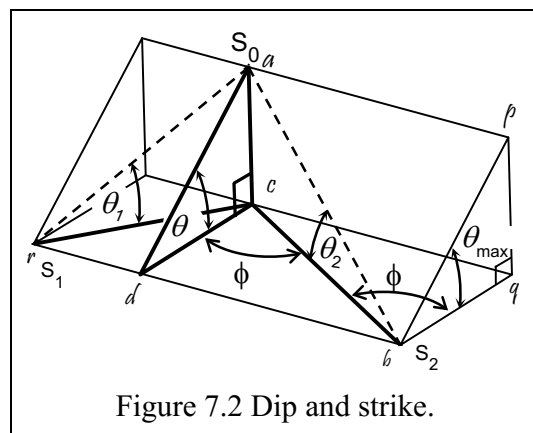

Figure 7.2 Dip and strike.

3. The apparent dip from a to r at S_1 (θ_1) (“apparent” means as observed or measured).
4. The included angle, ϕ (phi), is between the apparent dip to b , S_2 , and the true dip to $d\phi$ is the angle dcb . The line $bp = ad$.

From Figure 7.2 we will relabel θ_{\max} as θ for the development of the true dip formula.

1. $\tan \theta = \frac{ac}{cd} = \frac{pq}{qb}$, maximum dip, and
2. $\tan \theta_2 = \frac{ac}{cb} = \frac{pq}{cb}$, because $ac = pq$.

$\frac{pq}{cb}$ is the cross product of the apparent and true dips at b (S_2). $\frac{pq}{cb} = \frac{pq}{bq} \times \frac{bq}{cb}$.

3. $\tan \theta_1 = \frac{ac}{cr} = \frac{pq}{cr}$

and again, this is the cross product $\frac{pq}{cr} = \frac{pq}{bq} \times \frac{bq}{cr}$ of the apparent and true dips at r (S_1).

We now have three dips defined: true dip, $\tan \theta$, apparent dip, $\tan \theta_1$; and apparent dip, $\tan \theta_2$. They are related by the common side, ac .

The two apparent dips are defined by their respective **cross** products.

$\tan \theta_2 = \frac{pq}{cb}$, $\tan \theta = \frac{pq}{qb}$, $\cos \phi = \frac{bq}{cb}$. Thus, by cross product, $\tan \theta_2 = \tan \theta \cos \phi$.

The included angle between the two apparent dips can be designated Δ (capital delta), angle rcb . This is the measured angle at $DH0$ between $DH1$ and $DH2$.

ϕ is the included angle between the true dip and apparent dip to S_2 , (see Figure 7.3).

Label the angle between the true dip and the apparent dip to S_1 , as δ (delta).

So $\delta = \Delta - \phi$, thus $\phi = \Delta - \delta$.

$$\tan \theta_2 = \tan \theta \cos \phi \Rightarrow \tan \theta \cos (\Delta - \delta)$$

Expanding $\tan \theta \cos (\Delta - \delta) \Leftrightarrow (\cos \Delta \cos \delta + \sin \Delta \sin \delta)$

$$1. \text{ Eqn 1 } \tan \theta_2 = \tan \theta (\cos \Delta \cos \delta + \sin \Delta \sin \delta)$$

Apparent dip $\tan \theta_1$ is defined by its cross product such that:

$$\tan \theta_1 = \frac{pq}{cr}, \tan \theta = \frac{pq}{bq}, \cos \delta = \frac{bq}{cr}. \text{ So,}$$

$$2. \text{ Eqn 2 } \tan \theta_1 = \tan \theta \cos \delta$$

As Δ is known, we now have two expressions with **$\tan \theta$** common, linked by **$\sin \delta$** and **$\cos \delta$** , which will allow the calculation of the angle δ .

Remember, we are using the preceding formula to calculate the deflection angle, δ , which is measured from the true dip, $\tan \theta$, to the apparent dip at S_1 , $\tan \theta_1$.

Thus, the true dip, (from Eqn 2), $\tan \theta = \frac{\tan \theta_1}{\cos \delta}$. The dip angle, $\theta = ATAN \left(\frac{\cos \delta}{\tan \theta_1} \right)$.

If we have the orientation (azimuth) of either of the apparent dips and the included angle

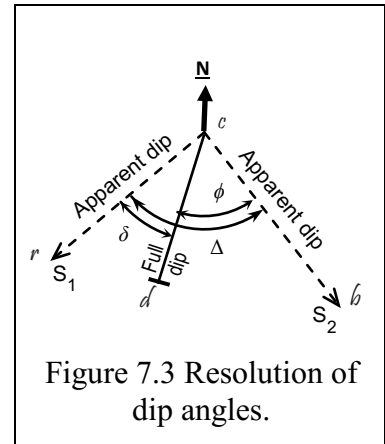

Figure 7.3 Resolution of dip angles.

between the two apparent dip lines, then we can calculate the azimuth of the true dip.

The strike line has **no** dip and is perpendicular to the true dip. If the plane is dipping down, then the strike azimuth is the dip azimuth – 90°.

7.4.1 Strike and Dip of a Plane, a Worked Example by Calculation

A geologist returns from a field trip with the following information on three drill holes: Figure 7.4

DH0, RL100, intercepted a seam, S₀ at a depth of 10m

DH1, RL95, 72m from DH0, azimuth 063° intercepted the seam, S₁, at a depth of 22m

DH2, RL90, 111m from DH0, azimuth 130° intercepted the seam, S₂, at a depth of 32m

Calculate the strike and dip of the seam. Figure 7.4 shows the two planes.

RL of seam intersects and depth (dH) below S₀ datum.

RL S₀ = 100 – 10 = 90 (the highest)

RL S₁ = 95 – 22 = 73 dH_{S₀-S₁} = 90 – 73 = 17

RL S₂ = 90 – 32 = 58 dH_{S₀-S₂} = 90 – 58 = 32

Horizontal distances and apparent dips

(tan θ = rise/run)

d_{S1} = 72m, dip_{S1} (tan θ₁) = 17/72 = 0.236 = 1:4.24

d_{S2} = 111m, dip_{S2} (tan θ₂) = 32/111 = 0.288 = 1:3.47

Included angle between apparent dip lines

Δ = Az_{S2} – Az_{S1} = 130 – 63 = 67°

Evaluate eqn 1:

$$\tan \theta_1 = \tan \theta (\cos \Delta \cos \delta + \sin \Delta \sin \delta)$$

$$\frac{1}{4.24} = \tan \theta (\cos 67 \cos \delta + \sin 67 \sin \delta)$$

$$\tan \theta = \frac{1}{4.24 (\cos 67 \cos \delta + \sin 67 \sin \delta)}$$

Evaluate eqn 2: tan θ₂ = tan θ cos δ

$$\frac{1}{3.47} = \tan \theta \cos \delta$$

$$\tan \theta = \frac{1}{3.47 \cos \delta}$$

We now have two equal expressions for tan θ.

invert each one and express the equality:

$$4.24 (\cos 67 \cos \delta + \sin 67 \sin \delta) = 3.47 \cos \delta \quad (\text{where } \cos 67 = 0.39, \sin 67 = 0.92)$$

$$4.24 (0.39 \cos \delta + 0.92 \sin \delta) = 3.47 \cos \delta \Rightarrow 1.65 \cos \delta + 3.90 \sin \delta = 3.47 \cos \delta. \text{ Gather terms}$$

$$3.90 \sin \delta = 3.47 \cos \delta - 1.65 \cos \delta \Rightarrow 3.90 \sin \delta = 1.82 \cos \delta$$

Now, as tan δ can be expressed in terms of sin δ and cos δ, solve for δ

$$\tan \delta = \frac{\sin \delta}{\cos \delta} = \frac{1.82}{3.90} = 0.467. \text{ Thus } \delta = \text{ATAN}(0.467) = 25.03, \delta = 25^\circ 01'$$

$$\text{Azimuth to full dip} = \text{Az}_{S2} - \delta = 130 - 25 = \mathbf{105^\circ}$$

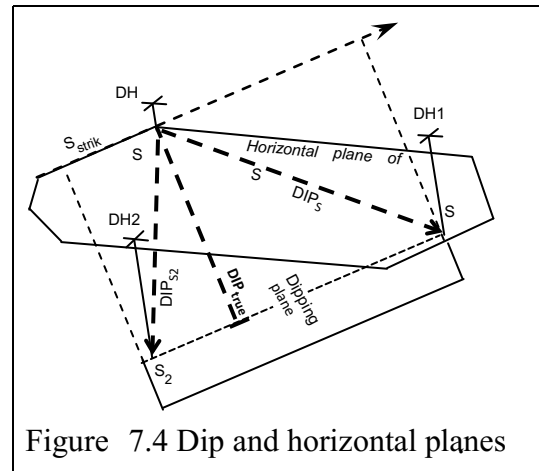

Figure 7.4 Dip and horizontal planes

See the plan in Figure 7.5

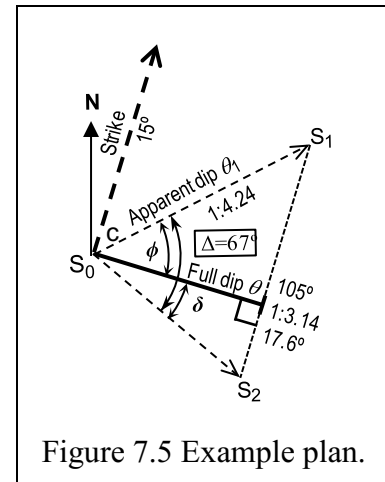

Figure 7.5 Example plan.

Strike azimuth = $105 - 90 = 15^\circ$

Now evaluate full dip **tan θ** using equation 2, Dip S_2 , where $\tan \theta_2 = 1:3.47$

From eqn.2: $\tan \theta_2 = \tan \theta \cos \delta$. Full dip, $\tan \theta = 1 : x$

$$\frac{1}{3.47} = \frac{1}{x} \cos 25 \Rightarrow x = 3.47 \cos 25 = 3.14$$

Rate of full dip = 1 in 3.14 = $\text{ATAN}(1/3.14) = 17.6^\circ$.

With the orientation of the strike and true dip you are now in a position to be able to calculate depths to seam from any point in the exploration area.

Volume of overburden and all the other tasks associated with mine development can now be calculated.

7.4.2 Strike and Dip of a Plane, the Graphical Solution

The previous complex calculations can be simplified by using a graphical solution derived from the observed data. It also allows visualisation of the observations, and can be done in the field. Referring to the plan in Figure 7.5, it can be seen that the true dip, θ , is less than any apparent dip, θ_1 . The slope is at its steepest point at θ_{\max} .

A geologist returns from a field trip with the following information on three different drill holes: Figure 7.4

DH0, RL100, intercepted a seam, S_0 at a depth of 7m.

$$\text{RLS}_0 = 100 - 7 = 93$$

DH1, RL95, 70m from DH0, azimuth 070° intercepted the seam, S_1 , at a depth of 25m.

$$\text{RLS}_1 = 95 - 25 = 70, \text{ rise to } \text{RLS}_0 = 93 - 70 = 23, \text{ run} = 70$$

DH2, RL90, 100m from DH0, azimuth 130° intercepted the seam, S_2 , at a depth of 38m.

$$\text{RLS}_2 = 90 - 38 = 52, \text{ rise to } \text{RLS}_0 = 93 - 52 = 41, \text{ run} = 100$$

From this information, where $\tan = \text{rise/run}$:

$$\text{dip}_1 (\tan \theta_1) = 23/70 = 0.33 = 1:3.03.$$

$$\text{Azimuth, } \text{Az}_1 = 070$$

$$\text{dip}_2 (\tan \theta_2) = 41/100 = 0.41 = 1:2.44.$$

$$\text{Azimuth, } \text{Az}_2 = 130.$$

Draw a plan closely to scale. Designed to fit in an A5 field book. See Figure 7.6.

1) From S_0 ,

a) draw a line on a bearing of 70° towards S_1
for a distance 3.03 units (say $3.03 * 20 = 60.6\text{mm}$)

b) draw a line on a bearing of 130° towards S_2
for a distance of 2.44 units ($2.44 * 20 = 48.8\text{mm}$).

2) Join S_1 and S_2 . From this base line, draw a perpendicular through S_0 .

Measure the distance from the base to S_0 (46mm) and convert to dip units $49/20 = 2.30$

the **true dip** is $1:2.30 = \text{atan}(1/2.30) = 23.5^\circ$

measure the bearing of the true dip from $S_0 = 111^\circ$

calculate bearing of strike = $111 - 90 = 21^\circ$

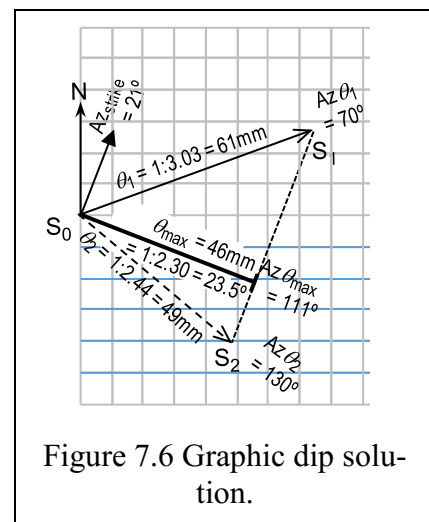

With a carefully drawn diagram it is then possible to find the apparent dip in any direction by scaling to the strike line between S_1 and S_2 . Figure 7.7 illustrates the next two problems.

What is the apparent dip on a bearing of 90° from S_0 ?

Draw a line to intercept the strike line between S_1 and S_2 .

It measures 50mm and at a scale of 1:20.

The dip = 1:2.5 (22°).

What is the azimuth of the 1:4 dip line?

The scale factor requires an 80mm line be drawn to intercept the strike line (extended past S_1).

Measure its azimuth as 57° .

The angle between apparent and full dip, recall Figure 7.3,

$\delta = 111 - 57 = 54^\circ$. Because of symmetry to the dipping plane it means that there is another azimuth to the 1:4 apparent dip. It is true dip + δ , = $111 + 54 = 165^\circ$

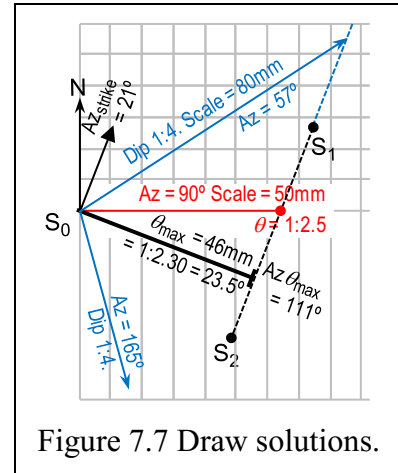

Figure 7.7 Draw solutions.

7.4.3 Maximum Dip “Outside” Strike Lines

Be aware that drill hole data may lead to some “funny” results.

It can be seen that if the field data, from the worked example in Section 7.4.1, for DH2 had been:

- DH2, RL90, 111m from DH0, azimuth 80° intercepted the seam, S_2 , at a depth of 32m, then a scale drawing as shown in Figure 7.8 would have revealed the direction of full dip as being further south of DH2. The S_2 distance can intercept the strike line at S_2 or S_2' , as shown.

Mathematical calculation may have caused concern at a negative answer because the angle $\Delta = 17^\circ$, and δ would result in a value of $\delta = -25^\circ$.

The full dip azimuth, Az_0 , is still;

$$Az_0 = Az_2 - \delta = 80 - (-25) = 105^\circ$$

As with the DH2 azimuth being 130° the formula provides:

$$4.24(\cos 17 \cos \delta + \sin 17 \sin \delta) = 3.47 \cos \delta$$

$$\text{(where } \cos 17 = 0.96, \sin 17 = 0.29)$$

$$4.24(0.96 \cos \delta + 0.29 \sin \delta) = 3.47 \cos \delta$$

$$\Rightarrow 4.05 \cos \delta + 1.24 \sin \delta = 3.47 \cos \delta. \text{ Gather terms}$$

$$1.24 \sin \delta = 3.47 \cos \delta - 4.05 \cos \delta$$

$$\Rightarrow 1.24 \sin \delta = -0.58 \cos \delta$$

$$\tan \delta = \frac{\sin \delta}{\cos \delta} = \frac{-0.58}{1.24} = -0.465.$$

$$\text{Thus } \delta = \text{ATAN}(-0.465) = -25, \delta = -25^\circ$$

$$\text{Azimuth to full dip} = Az_{S_2} - \delta = 80 - (-25) = \mathbf{105^\circ}$$

The maximum dip azimuth is equidistant between two equal apparent dips.

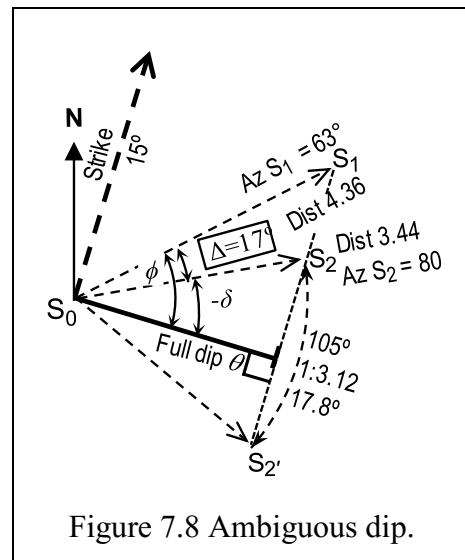

Figure 7.8 Ambiguous dip.

7.5 Seam Thickness

Having calculated the true dip, θ , the **thickness** of the seam can be calculated.

From the worked example in Section 7.4.1, the seam was intercepted 10m vertically below DH0. Continued vertical drilling resulted in an **apparent** seam thickness(d_a) of 16m. What is the **true** thickness (d_t) of the seam?

In Figure 7.9,

Depth to seam, $h = 10\text{m}$

True dip, $\theta = 1:3.16 = 17.6^\circ$

true thickness, $d_t = \text{apparent } (d_a)\cos\theta$

seam (d_t) = $16 \cdot \cos(17.6) = \mathbf{15.2\text{m}}$.

Consider an inclined drill hole, DH1, which is inclined away from the strike line. Drilling starts at +7 from the strike line through DH1 at an inclination of +10° from the vertical away “down slope” (The inclination is 27.6° perpendicular to the seam).

At DH1:

Inclination angle to seam normal, $I = 27.6^\circ$

Advance from strike, $s = 7$

Vertical depth to seam = $h + s/\theta = 10 + (7/3.16) = 12.2$

Incline depth to seam from DH1: $ab = 12.2 \cdot \cos(17.6) = 11.6$

Seam thickness, $bc = d_t = 15.2$

Distance to top seam (S_{1T}) = $ab\cos I = 11.6/\cos(27.6) = 13.1$

Distance to base seam (S_{1B}) = $(ab+bc)/\cos I = (11.6 + 15.2)/\cos(27.6) = 30.2$

Apparent core interval $S_{1B} - S_{1T} = 30.2 - 13.1 = 17.1$.

Or, core length = $d_t/\cos I = 15.2/\cos(27.6) = 17.1\text{m}$.

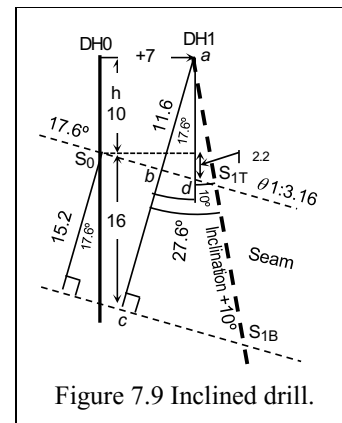

Figure 7.9 Inclined drill.

7.6 Depth to Seam

Once the strike line azimuth and the true dip, θ , have been determined, it is possible to calculate the depth to the seam at any point. The reference level is initially the level of S_0 . The depth to the seam is then dependent on the departure (distance east or west) from the strike line.

Referring to Worked Example 1 in Section 7.4.1, assuming the ground to the west of DH0 was flat (RL100) then the seam, 10m below DH0, should penetrate the surface some 32m west on the dip line through of DH0 (10 x true dip, $\theta = 31.6$).

Figure 7.10 is a plan of the drilling programme.

Bearings and distances to DH1 and DH2

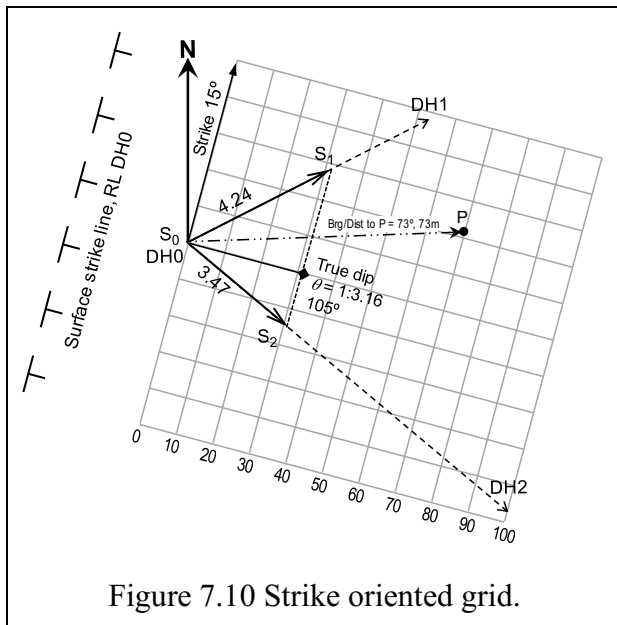

Figure 7.10 Strike oriented grid.

from DH0 are to scale. A scaled 10m grid has overlaid the seam, oriented in the direction of the strike.

With S_0 as datum, the depth to any point on the seam can be calculated by scaling in the direction of the dip. By inspection, scaled S_2 appears about 101m east of S_0 . Depth to S_2 below

$$S_0 = 101/3.16 = 31.9.$$

This agrees with original data of 32m.

The easiest way to determine position on the rotated grid is to set up at a known point (say DH0) and zero-set the Total Station to the strike azimuth.

Grid Brg to DH1 = AzDH1 – Az Strike = 63 – 15 = 48°.

Sight to DH1, note the direction, subtract 48°, turn to new direction. Then Zero Set the TS [0 SET]. E.g., HAR to DH1 = 105°, turn to HAR (105-48) = 57°. Zero Set to strike azimuth.

Thus, any bearing and horizontal distance (H) can be converted to local dE and local dN by the standard rectangular formulae, dE = H sin(brg), dN = H cos(brg).

The depth (h) to the seam at any point (reference RL S₀) can be calculated:

Worked example 1. e.g., Point DH P in Figure 7.10.

At DH0 a sight was taken to P,

Az (HAR) = 70, ZA = 99° 20', slope distance = 74m.

Grid Brg from strike line = 70°,

Dist 73m. dE = 70, dN = 21.

$$h_p = dE_{S_0}/\text{true dip}$$

$$h_p = 70/3.16 = 22.2\text{m below } S_0$$

$$RL S_p = RL S_0 - h_p = 90 - 22.2 = 67.8,$$

The profile between DH0 and DH P is shown in Figure 7.11.

RL S_p = 68m, the RL of the seam at P.

From DH1, RL = 100, the difference in height to P,

$$dH = 74 \times \cos(99.33^\circ) = -12\text{m}$$

$$RL DH P = RL DH0 - dH = 100 - 12 = 88\text{m}$$

$$\text{Depth to seam at DH P} = 88 - 68 = 20\text{m}.$$

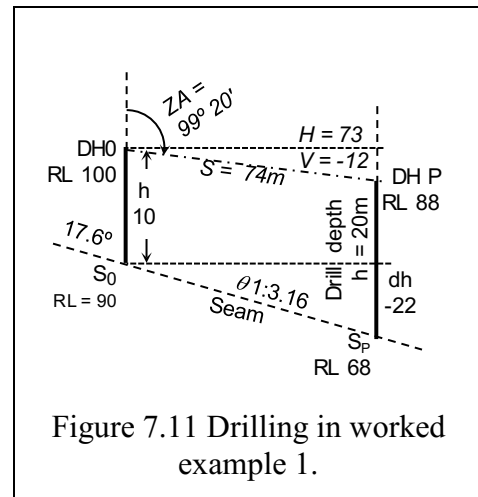

Figure 7.11 Drilling in worked example 1.

7.7 Direction of Any Slope Over the Dipping Surface

Investigate the **direction** of desired apparent dip. **Draw** a design apparent dip of 1:6.

The direction of **any** apparent dip can be realised graphically by scaling the dip until it meets the strike line perpendicular to the true dip. There will be two intercepts as illustrated.

Use a compass to draw the dip radius of 6 units, θ₆, to the same scale used for the true dip, θ, to intercept the extended strike line through S₁, and S₂. Using Worked Example 1 in Section 7.4.1.

Figure 7.12 shows an apparent dip of 1:6 (θ = 6, 9.5°). A protractor shows an azimuth of about 47° or 163°.

Calculate the dip deflection angle, δ, between true dip, θ, and apparent dip, θ₆, as a check.

We have the expression (Eqn. 2) from Section 0, page 122:

$$\tan \theta_6 = \tan \theta \cos \delta \quad \text{so that} \quad \cos \delta = \frac{\tan \theta_6}{\tan \theta}.$$

Now: tan θ₆ is the apparent dip, 1:6

$$1/6 = 0.6667$$

tan θ is the true dip, 1:3.16

$$1/3.16 = 0.3165$$

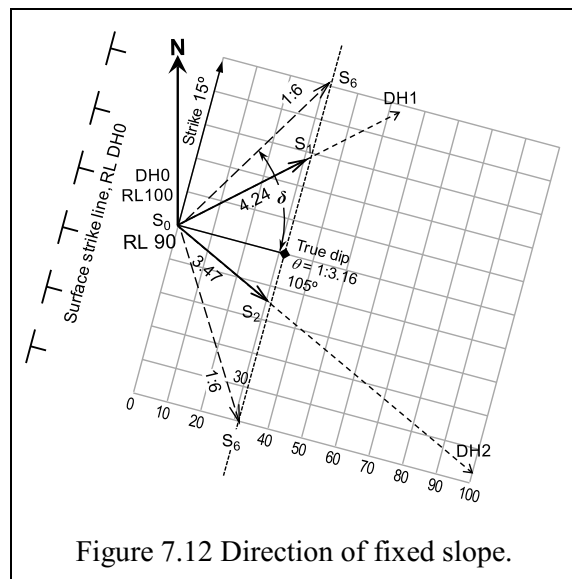

Figure 7.12 Direction of fixed slope.

$$\cos \delta = \frac{0.6667}{0.3165} = 0.5267 \quad \delta = 58.3^\circ$$

$$\begin{aligned} \text{Direction of apparent dip } 1:6 &= \text{true dip } \pm \delta \\ &= 105 + 58 = 163^\circ \text{ or} \\ &= 105 - 58 = 47^\circ. \end{aligned}$$

This agrees with the graphical solution and it is up to the engineer to pick the required direction.

Any point on a line of bearing of 47° (or 163°) will have an apparent dip of 1:6 on this seam plane.

At a distance (H) of 100m, the depth (h) to the plane, below DH0 at S_0 , will be:

$$h = H_{\text{dist.}} \cdot \tan \theta_6.$$

$$H = 100, h = 100/6 = 16.7\text{m. And from the Figure 7.12, RL } S_0 = 90\text{m.}$$

$$\text{RL } S_6 = 90 - 17 = 73\text{m.}$$

We still require the RL at the surface at the chosen point, DH6, to establish the drill depth to the seam. This would be achieved using the Zenith Angle (ZA) and slope distance when setting the position of DH6 from DH0 as shown in worked example 1.

7.8 Horizontal Angles Projected on to an Inclined Plane

The deflection angles that have been developed for dipping plane have been **horizontal** angles. The question arises as to the value of the included angle on the inclined plane. Theodolites measure horizontal angles and inclinations (vertical angles). Only a **sextant**, sighting to two targets on an inclined plane, can read the inclined angle. The astronomic "method of lunars" solved longitude (time) problems by using a sextant to measure the inclined angle between a bright star or planet and the moon.

Inclined angles are needed for the manufacture of pipework or ducting elbows along any inclined surface. The angular difference between horizontal and inclined may not be great, but it may be significant on steep inclinations.

In Figure 7.13:

AC_1 and BC_1 are inclined to the horizontal plane ACB .
inclinations at A and B are α and β respectively.

horizontal angle $ACB = \theta$

incline angle $AC_1B = \lambda$

height difference $CC_1 = h$

Now:

$$AC = h \cot \alpha, \quad AC_1 = h \operatorname{cosec} \alpha \quad \cot = 1/\tan$$

$$BC = h \cot \beta \quad BC_1 = h \operatorname{cosec} \beta \quad \operatorname{cosec} = 1/\sin$$

In triangle ACB , by cos rule for sides

$$AB^2 = AC^2 + BC^2 - 2AC \cdot BC \cos \theta$$

$$AB^2 = h^2 \cot^2 \alpha + h^2 \cot^2 \beta - 2h^2 \cot \alpha \cot \beta \cos \theta$$

Similarly, in triangle AC_1B , by cos rule for sides

$$AB^2 = h^2 \operatorname{cosec}^2 \alpha + h^2 \operatorname{cosec}^2 \beta - 2h^2 \operatorname{cosec} \alpha \operatorname{cosec} \beta$$

$\cos \lambda$

By similarity, and gathering terms:

$$h^2 \cot^2 \alpha + h^2 \cot^2 \beta - 2h^2 \cot \alpha \cot \beta \cos \theta = h^2 \operatorname{cosec}^2 \alpha + h^2 \operatorname{cosec}^2 \beta - 2h^2 \operatorname{cosec} \alpha \operatorname{cosec} \beta \cos \lambda$$

$$2h^2 \operatorname{cosec} \alpha \operatorname{cosec} \beta \cos \lambda = h^2 \operatorname{cosec}^2 \alpha + h^2 \operatorname{cosec}^2 \beta - h^2 \cot^2 \alpha + h^2 \cot^2 \beta + 2h^2 \cot \alpha \cot \beta \cos \theta$$

$$2h^2 \operatorname{cosec} \alpha \operatorname{cosec} \beta \cos \lambda = h^2 (\operatorname{cosec}^2 \alpha + \operatorname{cosec}^2 \beta - \cot^2 \alpha + \cot^2 \beta + 2 \cot \alpha \cot \beta \cos \theta),$$

(gathering terms and cancelling h^2)

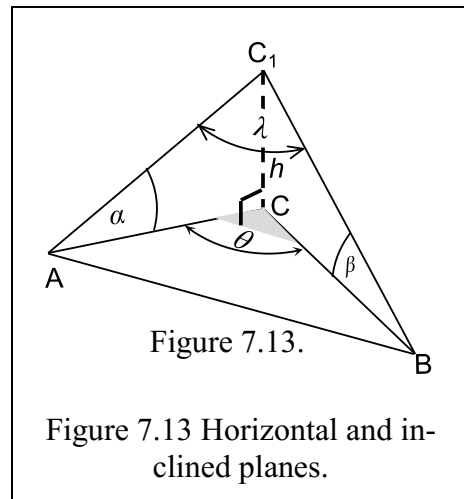

Thus, expressing the similarity in terms of inclined angle λ

$$\cos \lambda = \frac{(\operatorname{cosec} 2\alpha - \cot 2\alpha) + (\operatorname{cosec} 2\beta - \cot 2\beta) + 2 \cot \alpha \cot \beta \cos \theta}{2 \operatorname{cosec} \alpha \operatorname{cosec} \beta}$$

Because, from general trigonometric proof: $1 + \cot^2 A = \operatorname{cosec}^2 A$, then $\operatorname{cosec}^2 A - \cot^2 A = 1$

$$\operatorname{cosec}^2 \alpha - \cot^2 \alpha = 1 = \operatorname{cosec}^2 \beta - \cot^2 \beta$$

Thrashing valiantly through the enlightening jungle of trigonometric obfuscation to the sunlit up-lands,

$$\cos \lambda = \frac{1+1+2 \cot \alpha \cot \beta \cos \theta}{2 \operatorname{cosec} \alpha \operatorname{cosec} \beta} = \frac{2(1 + \cot \alpha \cot \beta \cos \theta)}{2 \operatorname{cosec} \alpha \operatorname{cosec} \beta} = \frac{1 + \frac{1}{\tan \alpha} \frac{1}{\tan \beta} \frac{\cos \theta}{1}}{\frac{1}{\sin \alpha} \frac{1}{\sin \beta}}$$

$$\cos \lambda = \sin \alpha \sin \beta + \frac{\cos \alpha \cos \beta}{\sin \alpha \sin \beta} \cos \theta \frac{\sin \alpha \sin \beta}{1 \cdot 1} \text{ and, cancelling through by } \sin \alpha \text{ and } \cos \beta :$$

Extract the **inclined** angle, λ , in terms of inclination and **horizontal** angle, θ .

$$\cos \lambda = \sin \alpha \sin \beta + \cos \alpha \cos \beta \cos \theta \quad \textbf{Inclined angle.}$$

Extract the **horizontal** angle, θ , in terms of inclination and **inclined** angle, λ .

$$\cos \theta = \frac{\cos \lambda - \sin \alpha \sin \beta}{\cos \alpha \cos \beta} \quad \textbf{Horizontal angle.}$$

The formula is sensitive to the sign of the inclination of the two lines at the intersection (the bend). A continuing falling decline will have one positive inclination to, and one negative inclination away from, the intersection.

7.8.1 Worked Example 2

A pipe is to be installed along two intersecting declines. The coordinates of the pipe supports provide the following information:

The horizontal angle at the bend is 63°

one decline, A-C₁, rises at a gradient of 1:3.

the second decline, B-C₁, rises on a gradient of 1:4

Both declines are rising **to** the intersection, so each gradient is positive to the high point.

Determine the inclined angle at the intersection, C₁:

Figure 7.14

Data:

$$C = \theta = 63^\circ$$

$$A = \alpha = \operatorname{ATAN}(1/3) = 18.43^\circ$$

$$B = \beta = \operatorname{ATAN}(1/4) = 14.03^\circ$$

Formula:

$$\cos \lambda = \sin \alpha \sin \beta + \cos \alpha \cos \beta \cos \theta$$

Solution:

$$\begin{aligned} \cos \lambda &= \sin(18.43)\sin(14.03) \\ &\quad + \cos(18.43)\cos(14.03)\cos(63) \\ &= 0.316 \cdot 0.242 + 0.949 \cdot 0.97 \cdot 0.454 \\ &= 0.077 + 0.417 \end{aligned}$$

$$\cos \lambda = 0.494$$

$$\lambda = 60.36^\circ$$

Inclined angle, C₁ = $60^\circ 21'$

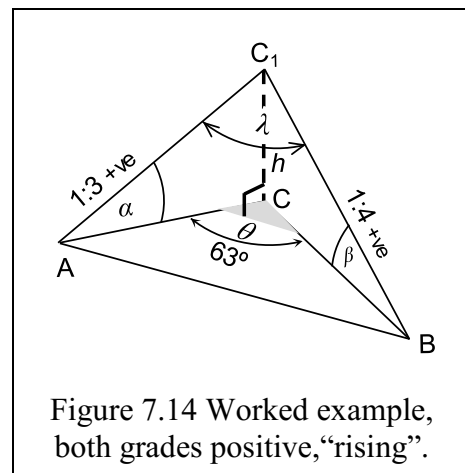

7.8.2 Worked Example 3

A pipe is to be installed along two intersecting declines. The coordinates of the pipe supports provide the following information:

The horizontal angle at the bend is 63°

one decline, A-C₁, rises at a gradient of 1:3.

the second decline, C₁-B, continues rising on a gradient of 1:4

One decline rises **to** the intersection, C₁,
the other continues rising **from** C₁

so one gradient is positive A-C₁

the other is negative B-C₁.

(It falls **to** the intersection)

Determine the inclined angle at intersection, C₁:

see Figure 7.15

Data:

$$C = \theta = 63^\circ$$

$$A = \alpha = \text{ATAN}(1/3) = 18.43^\circ$$

$$B = \beta = \text{ATAN}(1/-4) = -14.03^\circ$$

Formula:

$$\cos \lambda = \sin \alpha \sin \beta + \cos \alpha \cos \beta \cos \theta$$

Solution:

$$\begin{aligned} \cos \lambda &= \sin(18.43)\sin(-14.03) \\ &\quad + \cos(18.43)\cos(-14.03)\cos(63) \\ &= 0.316 \cdot -0.242 + 0.949 \cdot 0.97 \cdot 0.454 \\ &= -0.077 + 0.417 \end{aligned}$$

$$\cos \lambda = 0.340$$

$$\lambda = 70.14^\circ$$

$$\text{Inclined angle, } C_1 = 70^\circ 08'$$

Note that only the **sine** changes sign as the **sign** of the inclination changes. If both inclinations were negative, it wouldn't matter as the product of the two negative sines is a positive, as in Worked example 1.

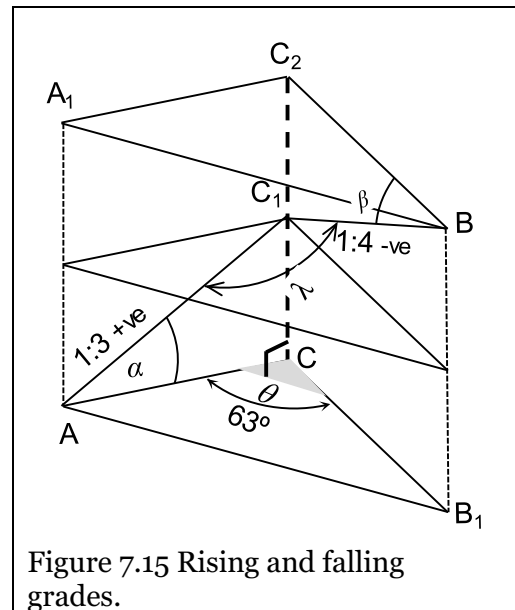

Figure 7.15 Rising and falling grades.

7.9 Concluding Remarks

This chapter is a demonstration of elements used to calculate on the dipping plane. We hope we have shown that the process can, in simple cases, be solved in the field, either by simple mathematics or by graphical means.

Courses in Structural Geology introduce the subject of a dipping plane. They have not been investigated because the references to this chapter cover the subject more fully from the surveying and computational aspect.

7.10 Reference for Chapter 7

- 1 Shepherd, F.A, Surveying Problems and Solutions, Edward Arnold, 1968
- 2 Shepherd, F.A, Engineering Surveying, Problems and Solutions, Edward Arnold, 2nd ed, 1983

Chapter 8 Circular Curves

8.1 Introductory Remarks

At the end of this Chapter and having gone through the workshop and field practical materials, you should:

- Appreciate the geometric properties of a circular curve.
- Differentiate between different types of horizontal curves.
- Design curves of constant radii to join straight sections of roads and railways.
- Understand the base mapping necessary to assist an engineer in selecting a road or rail alignment.
- Setting out circular curves using either chord length and deflection angle; offset from the long chord; or coordinates methods.
- Understand how simple curves can be combined as compound and reverse curves.
- Horizontal Curves are made up of circular and transitional curves. They are used to:
 - ✓ ensure that vehicles travel safely from one section of the road or track to another.
 - ✓ Achieve horizontal alignment, i.e., the combination of horizontal curves and straight used in design.
- Circular curves have uniform radius.
- Transition curves have varying radius and are used:
 - ✓ To introduce radial force gradually and uniformly in order to minimize passenger discomfort
 - ✓ To gradually introduce super elevation, which involves raising one of the road channels relative to the other and enabling the effect of the radial force to be reduced.
 - ✓ In conjunction with circular curves to form composite curves or in pairs to form wholly transitional curves.

Circular curves are used in

- Used in Road and Rail alignment.
- A straight road would be ideal but terrain constraints, e.g., hills, buildings, rivers, etc. do not permit.
- Horizontal alignment thus joins the respective straight lines (called tangents). Alignments are chosen on digital maps which show contours, natural surface features and soil types.
- In very hilly country, alignments may be completely made up of curves (circular and transition).

The **tangent** and **chord** properties of a circle are shown in Figure 8.1.

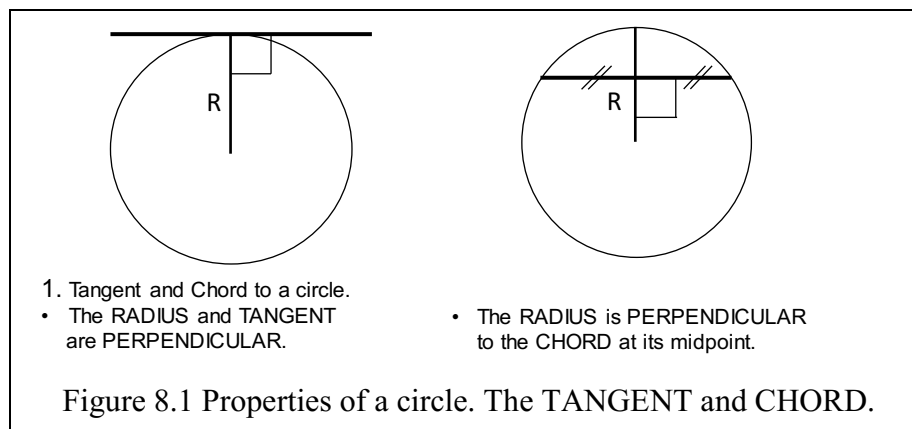

The **deflection** and **subtended angles** properties of a circle are shown in Figure 8.2.

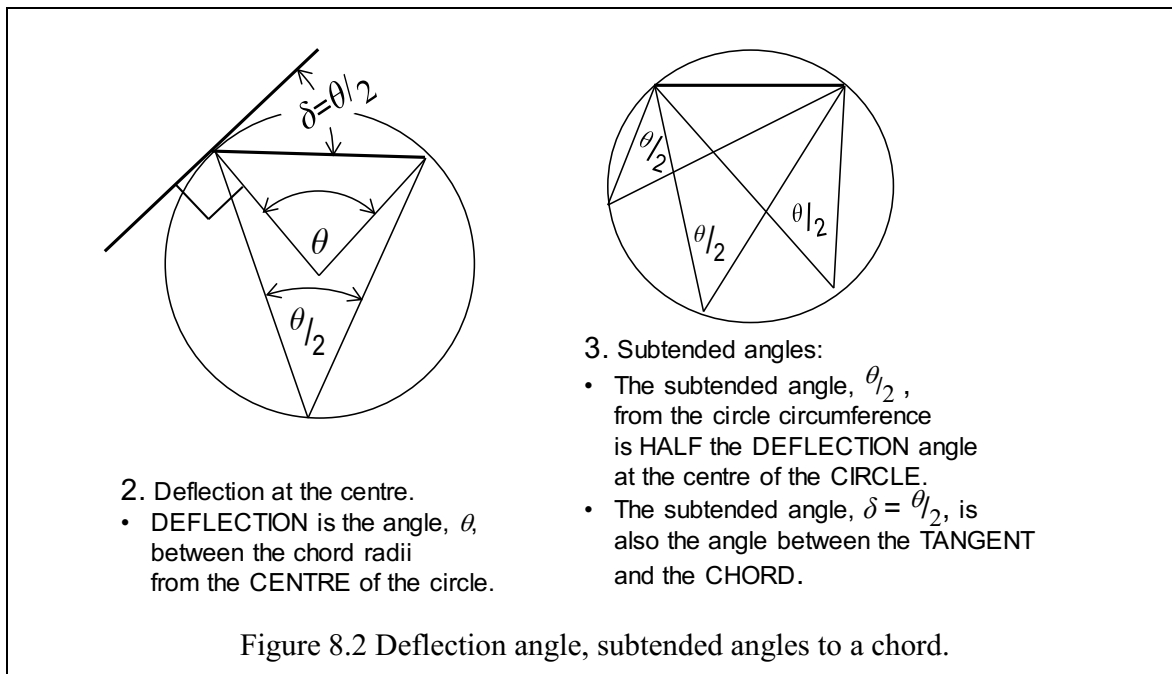

Types of circular curves are shown Figure 8.3

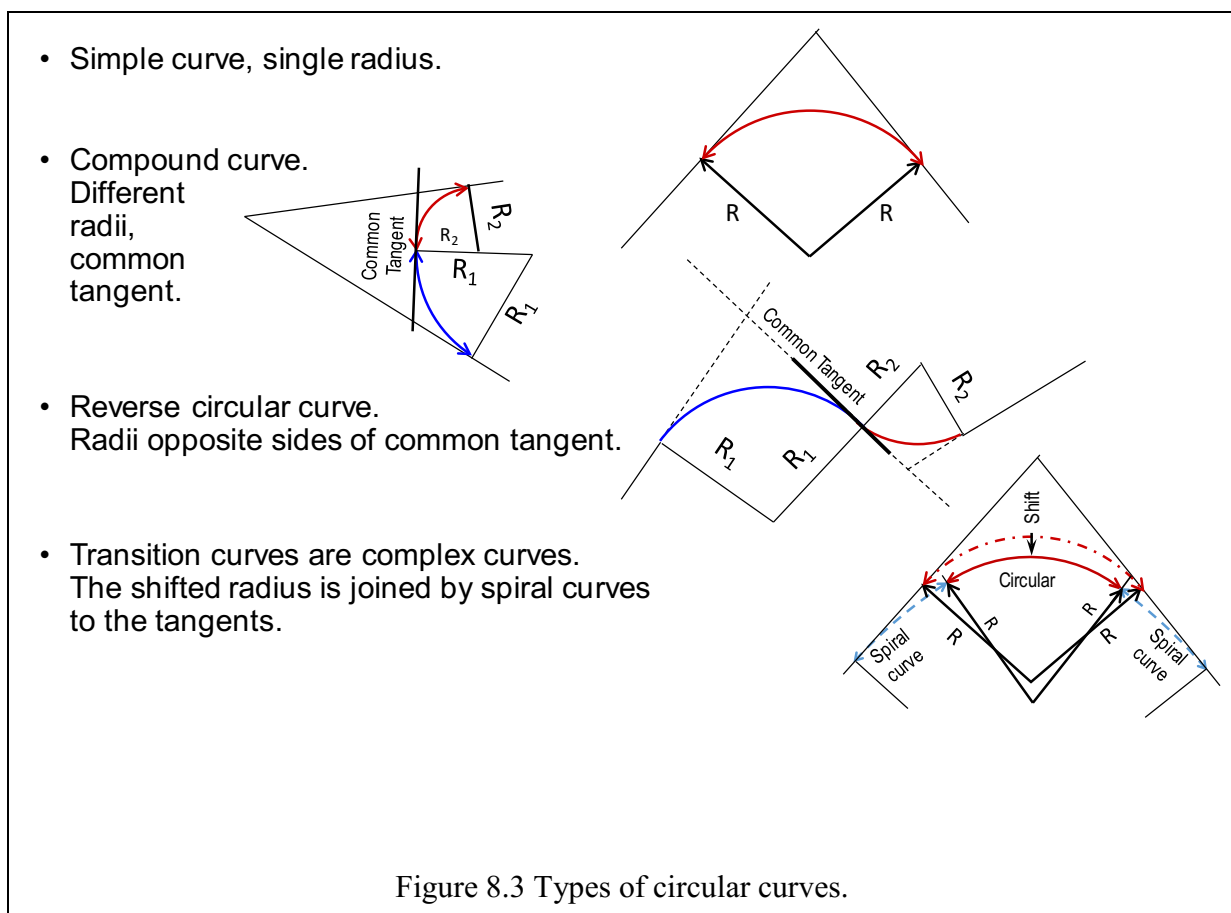

8.2 Generating a Circular Curve - A Process of Visualisation

The circular curve is the simple figure that joins two straight lines together. It is a thing of beauty once it has been laid out in the field. But it is also a bit of a mystery in its generation, until the basics are mastered. The development of the circular curve is best illustrated by a build-up of the elements of the curve.

8.2.1 Basic Formulae

All CIRCULAR calculations are carried out in RADIANS. $360^\circ = 2\pi$ (6.2832) radians.

$$\text{Arc, } S = R\theta(\text{radians}).$$

Figure 8.4 shows a simple curve of given RADIUS, R , joins two intersecting straight lines.

The straight lines differ in direction by a DEFLECTION angle, Δ (delta) degrees, at the INTERSECTION POINT (IP).

The curve has a CENTRE at the intersection of two RADII that are PERPENDICULAR to the two straight lines and are TANGENT POINTS to the curve. The radii are PERPENDICULAR to the straight lines AT the TANGENT POINTS.

The DEFLECTION angle, θ (theta), at the centre of the arc is equal to the deflection angle, Δ , at the intersection point (IP).

The LENGTH, S , of the ARC between the two tangent points, TPs, is given by the expression:

$$S = R\theta^{\text{radians}}$$

The ingoing curve starts at the tangent point, the POINT OF CURVATURE, PC, and its outgoing ends at the other tangent point, the POINT OF TANGENCY, PT.

Example:

Radius, $R = 200$

Deflection angle at IP, $\Delta = 80^\circ$

then $\theta = 80 \cdot \pi/180 = 1.3963$ radians

Arc, $S = 279.253$

8.2.2 The Tangent Distance

The line O-IP, joining the IP and the centre, O, bisects the deflection angle, Δ .

The triangles O-PC-IP and O-PT-IP are equal.

The length of the straight line from the PC to the IP and IP to PT is the TANGENT DISTANCE, TD.

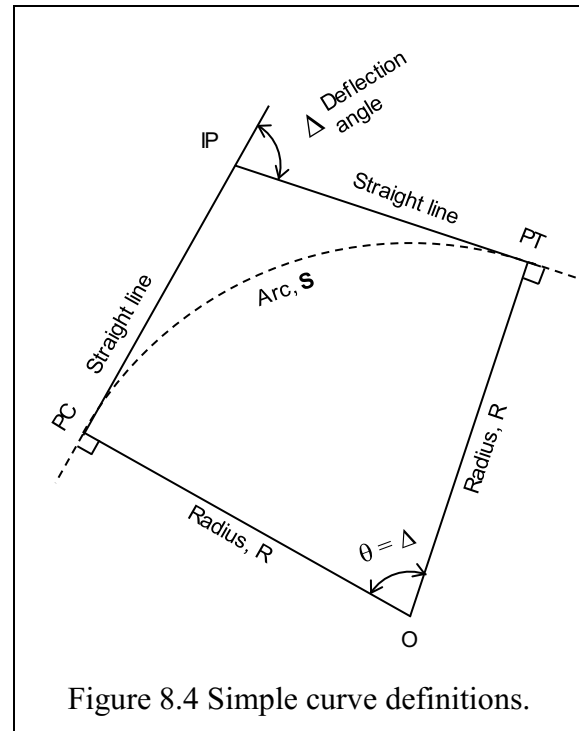

Figure 8.4 Simple curve definitions.

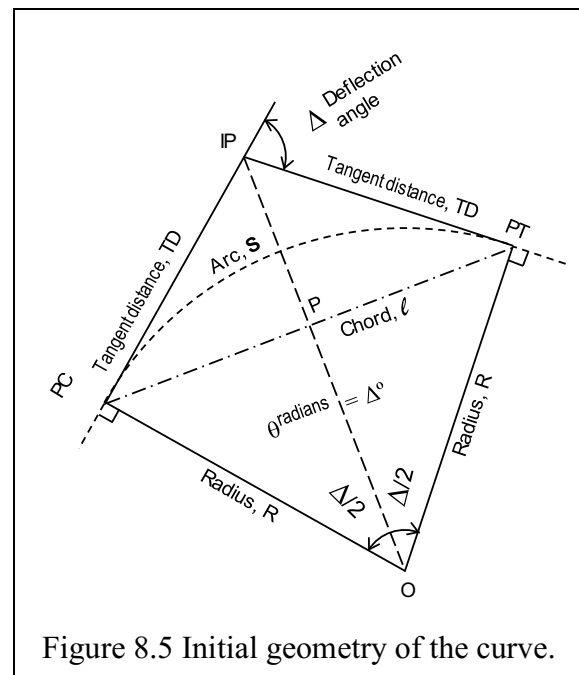

Figure 8.5 Initial geometry of the curve.

From plane trigonometry, the TD is the opposite side, and the radius, R, is the adjacent side of the triangle PC-O-IP from the half deflection angle $\Delta/2$.

In Figure 8.5 and Figure 8.6, in triangle O-PC-IP,

$$\tan\left(\frac{\Delta}{2}\right) = \frac{opp}{adj} = \frac{TD}{R}$$

$$TD = R \tan(\Delta/2) = 200 \tan(40^\circ) = 167.820$$

The two tangent distances are equal:

$$PC \text{ to } IP = IP \text{ to } PT$$

8.2.3 The Long Chord

The LONG CHORD, Figure 8.5, from PC to PT is made up of two half chords, PC – P, and P – PT.

As shown in Figure 8.7, in the triangle O-PC-P

$$\sin\left(\frac{\Delta}{2}\right) = \frac{opp}{hypot} = \frac{\ell/2}{R}. \text{ Thus } \ell/2 = R \sin\left(\frac{\Delta}{2}\right)$$

The long chord, of length ℓ , joining PC to PT, is:

$$\ell = 2R \sin(\Delta/2) = 400 \sin(40^\circ) = 257.115$$

The ANGLE between the TANGENT STRAIGHT and the CHORD at the tangent point is the CHORD DEFLECTION ANGLE, labelled δ (delta), is half the TANGENT deflection angle. $\delta^\circ = \Delta^\circ/2$.

Thus, in Figure 8.8, any point, **p**, on the arc at an arc distance, **s**, from the tangent point, is tangential to the arc at **p** towards the centre, **O**.

Notice the difference between the arc length, **S**, and the chord, ℓ .

Arc length,	S	= 279.253
Long chord	ℓ	= 257.115

8.2.4 The Chord Deflection Angle

It follows that, as: $s_p = R\theta_p$, then the TANGENT deflection

$$\theta_{p(\text{radians})} = s_p/R$$

and the angle, in degrees, is

$$\Delta_p^\circ = \theta_p \cdot 180/\pi$$

The CHORD deflection from the tangent point to **p** is:

$$\delta_p^\circ = \Delta_p/2$$

and the chord DISTANCE is:

$$\ell_p = 2R \sin(\delta_p^\circ)$$

From these formulæ we can now start to find some solutions to common circular curve problems.

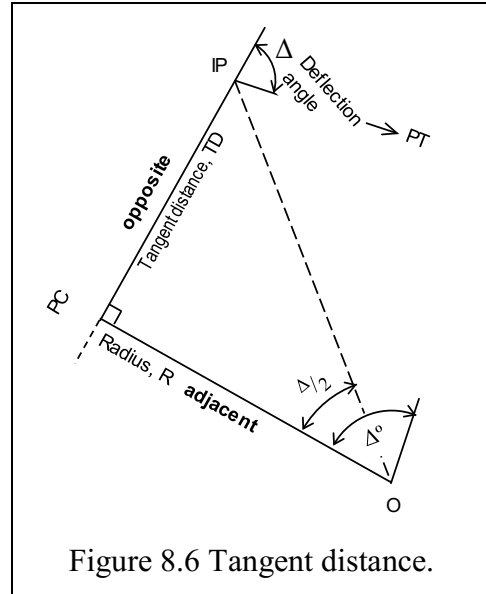

Figure 8.6 Tangent distance.

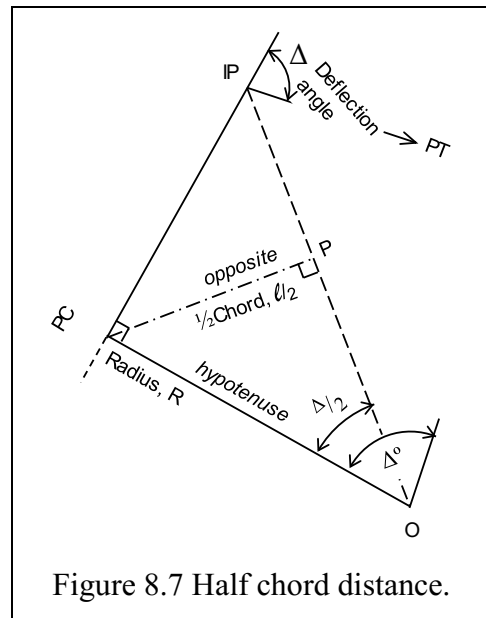

Figure 8.7 Half chord distance.

Worked Example 1

Suppose point p is 150m around the curve from the PC, Figure 8.8.

Find coordinates of P.

arc length, s = 150

$s_p = 150, R = 200:$

remember, as $S_p = R\theta_p$, then $\theta_p = s_p/R$

$$\theta_p = 150/200 = 0.75 \text{ radians}$$

$$\Delta_p = 42.972^\circ = 42^\circ 58' 19''$$

$$\delta_p = 21.486^\circ = 21^\circ 29' 09'' \text{ (half } \Delta)$$

$$\begin{aligned} \ell_p &= 2R \sin(\delta_p) = 400 \sin(21^\circ 29' 09'') \\ &= 146.509 \end{aligned}$$

The BEARING of the CHORD at the tangent point is the BEARING from the PC to the IP PLUS the TANGENT deflection angle, δ_p .

$$\text{BRG}_{PC - IP} = 35^\circ 20' 30''$$

$$\delta_p = 21^\circ 29' 09''$$

$$\text{BRG}_{PC - p} = 56^\circ 49' 39''$$

$$\ell_p = 146.509$$

The vector between the PC and p can be converted to rectangular coordinates:

$$\delta E_p = \ell_p \sin(\text{BRG}),$$

$$\delta N_p = \ell_p \cos(\text{BRG})$$

If the coordinates of the PC are known, then: $E_p = E_{PC} + \delta E_p$ and $N_p = N_{PC} + \delta N_p$.

Note that the points along the curve RADIATE from the PC.

All the calculated δE s and δN s are added to the PC coordinates.

Find coordinates of p from PC E100.00, N500.00

$$\text{BRG}_p = 56^\circ 49' 39'', \ell_p = 146.509 \text{ converts to } \delta E_p = 122.632, \delta N_p = 80.16$$

$$E_p = 222.632$$

$$N_p = 580.164$$

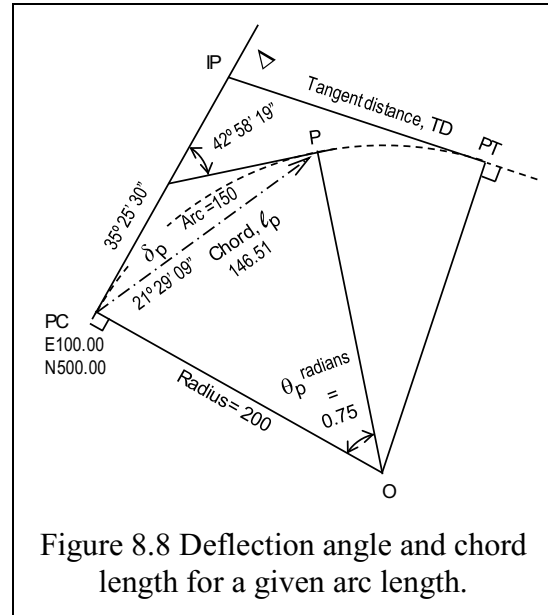

Figure 8.8 Deflection angle and chord length for a given arc length.

8.2.5 Chainage

In a lot of survey work the word chainage is used to express a linear distance from some start point, as opposed to a distance between two points (see Figure 8.9). Usually, they are the actual distance from the start point of the road or railway to points along the development. In the initial design of the curve several CHAINAGE values will be determined. These chainages generally apply from the start of the project along the straight lines defining path of the project.

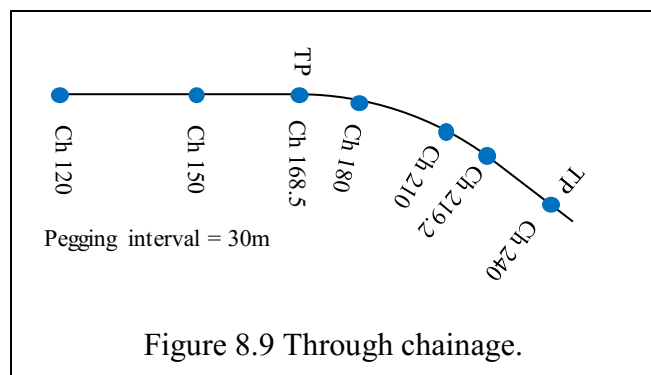

Figure 8.9 Through chainage.

In Figure 8.10, the chainage increases from Z along the straight to point TP1 where the circular curve begins. The chainage can either:

- (1) Increase along the straight to the intersection point (IP) This is used only for initial road set out before curves are designed

$$CH_{IP} = CH_{TP1} + TD.$$

- (2) Increase along the curve to TP2 - Used for road construction.

$$CH_{TP2} = CH_{TP1} + S.$$

In curve design this means that chainages will be determined for each of the IPs. When the curve radii are determined then the THROUGH CHAINAGE of the straights and curves will be calculated.

Chainage intervals at set distances, depending on design, will be used (e.g. every 50m). Figure 8.11 shows CH_{PC}, tangent distance, and arc length:

Chainage PC = chainage IP minus the tangent distance.

$$\begin{aligned} CH_{PC} &= CH_{IP} - TD. \\ &= 1496.27 - 167.820 \\ &= 1328.450 \end{aligned}$$

The through chainage of the next point on the curve will be a multiple of the chainage interval, say 50m, = CH1350.

The chainage PT = chainage PC plus the arc length, S.

$$\begin{aligned} CH_{PT} &= CH_{PC} + S \\ CH_{PT} &= 1328.450 + 279.253 \\ &= 1607.703. \end{aligned}$$

Chainage PT does NOT equal CH_{IP} + TD.

Other than chainages defining changes in direction, i.e. at the PC and PT, all the other calculations on the curve are generally carried out at defined chainage intervals.

Thus, in Figure 8.12, with a chainage interval of 50m, the points on the curve will be marked by even 50m chainages around the arc from the PC to the PT. The through arc distances, from the PC, can be tabulated for calculation of chord deflection and distance:

CH_{PC} = 1328.450, the next points, until CH_{PT} = 1607.703, are:

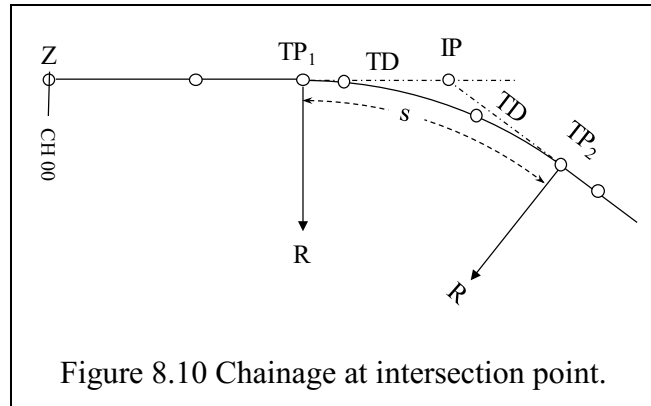

Figure 8.10 Chainage at intersection point.

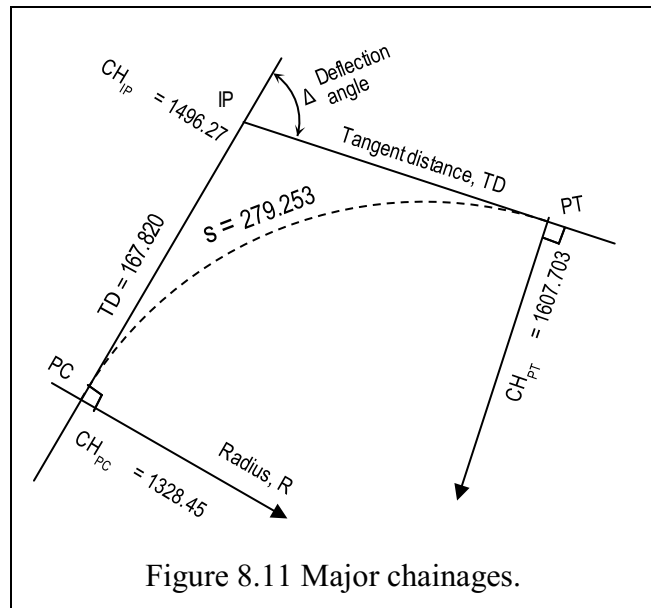

Figure 8.11 Major chainages.

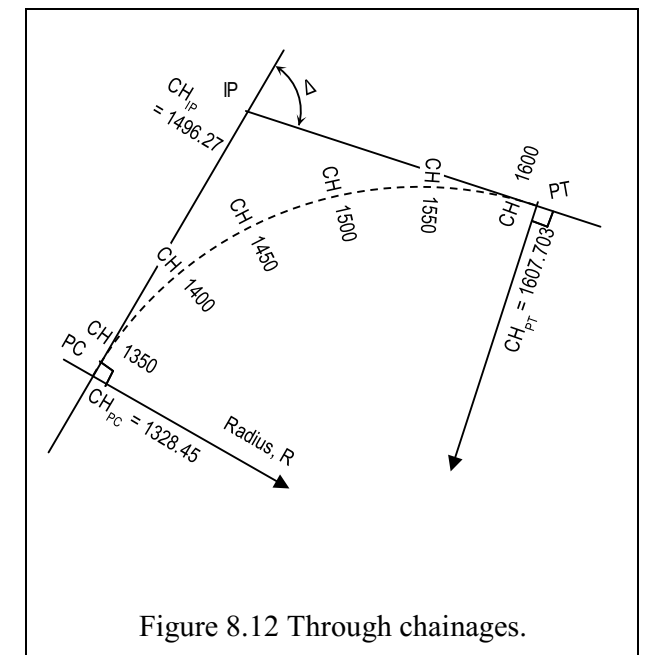

Figure 8.12 Through chainages.

CH ₁₃₅₀	= 1350.000	s = 21.550
CH ₁₄₀₀	= 1400.000	s = 71.550
CH ₁₄₅₀	= 1450.000	s = 121.550
CH ₁₅₀₀	= 1500.000	s = 171.550
CH ₁₅₅₀	= 1550.000	s = 221.550
CH ₁₆₀₀	= 1600.000	s = 271.550
CH _{PT}	= 1607.703,	s = 279.253.

This is the arc length from PC to PT. It is a check of your maths.

A table (Table 8-1) of deflection angles, bearings and chord lengths, coordinate differences, δE_p , δN_p , and coordinates, E_p , N_p can now be compiled using the derived formulas: referring to Figure 8.8:

Initial bearing, PC-IP = 35° 20' 30".

radius R = 200m,

deflection angle, $\Delta = 80^\circ$,

chainage interval 50m.

Chainage	s	$\theta_p = s_p/R$	$\delta_p = \frac{\Delta}{2}$	Brg ℓ_p	$\ell_p = 2R \cdot \sin(\delta_p)$	δE_p	δN_p	E_p	N_p
CH _{PC}	0.000	0.0	0 00 00	35 20 30	0.00	0.00	0.00	100.00	500.00
CH ₁₃₅₀	21.550	0.108	3 05 12	38 25 42	21.54	13.39	16.87	113.39	516.87
CH ₁₄₀₀	71.550	0.378	10 14 56	45 35 26	71.17	50.84	49.80	150.84	549.80
CH ₁₄₅₀	121.550	0.608	17 24 39	52 45 09	119.69	95.28	72.44	195.28	572.44
CH ₁₅₀₀	171.550	0.858	24 34 22	59 54 52	166.34	143.93	83.38	243.93	583.38
CH ₁₅₅₀	221.550	1.108	31 39 21	66 59 51	209.93	193.24	82.03	293.24	582.03
CH ₁₆₀₀	271.550	1.358	38 53 48	74 14 18	251.17	241.73	68.23	341.73	568.23
CH _{PT}	279.253.	1.396	40 00 00	75 20 30	257.12	248.75	65.06	348.75	565.06

Check: Deflection angle from the PC - PT, $\delta = 40^\circ = \frac{1}{2}\Delta$.

Distance PC - PT = $\ell_p = 2R\sin(\frac{1}{2}\Delta) = 257.12$.

8.2.6 In, Through and Out Arcs. Setout and Checking Tools

Calculating CHORDS; for the first arc (in arc), the chaining interval (through arc), and the last arc (out arc), allow checking of the curve set-out. On long curves the through chainage deflection angle and chord is required to advance the Total Station set-up stations. Referring to

$$\begin{aligned} \text{In arc} &= 1350 - 1328.45 = 21.55 \\ \delta &= \frac{1}{2}(21.55/200)^R = 0.054^R = 3^\circ 08' 12'' \\ \text{in chord} &= 2R\sin(\delta), \quad \text{in chord} = 21.54 \end{aligned}$$

$$\begin{aligned} \text{Through arc} &= \text{Chainage interval} = 50 \\ \delta &= \frac{1}{2}(50/200) = 0.125^R = 7^\circ 09' 43'' \\ \text{through chord} &= 49.87 \end{aligned}$$

$$\begin{aligned} \text{Out arc} &= 1607.703 - 1600 = 7.703 \\ \delta &= \frac{1}{2}(7.703/200) = 0.019^R = 1^\circ 06' 12'' \\ \text{out chord} &= 7.702 \end{aligned}$$

8.2.7 Calculating a Circular Curve: Definitions and Formulæ

The simple curve.

- 1) ASB is a simple curve of radius R connecting two straights EA and BF (See Figure 8.13)
- 2) A and B are the tangent points and the straights are produced to meet in D (the intersection point or point of intersection, PI or IP).
- 3) AD, BD are tangents to the curve and $AD = BD$.
 Δ is the deflection angle.
- 4) The deflection angle, Δ , equals the angle at the centre, $\angle ACB$
- 5) Triangles ADC and BDC are congruent and $\angle ACD = \angle BCD = \frac{\Delta}{2}$
- 6) Point S, on arc ASB, has a deflection angle $\angle DAS = \delta$, which is half of angle $\angle ACS = 2\delta$.

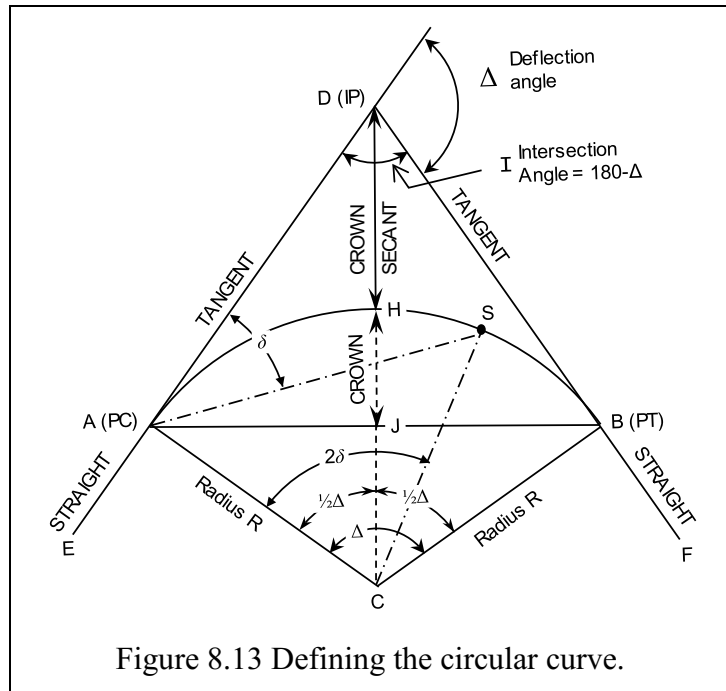

Figure 8.13 Defining the circular curve.

By definition:

The DIRECTION of the RADIUS is PERPENDICULAR to the TANGENT.
Brg Radius = Brg Tangent $\pm 90^\circ$

Formulæ.

- (i) Tangent Distance AD = $R \cdot \tan \frac{\Delta}{2}$
- (ii) Radius (R) = Tangent Distance (AD) $\cdot \cot \frac{\Delta}{2}$ (Cot = $\frac{1}{\tan}$)
- (iii) Arc length (AB) = $R \cdot \Delta$ (Δ measured in radians)
- (iv) Secant Distance (DC) = $R \cdot \sec \frac{\Delta}{2}$ (Sec = $\frac{1}{\cos}$)
- (v) Crown Secant (DH) = $R \cdot \sec \frac{\Delta}{2} - R$ = $R \cdot (\sec \frac{\Delta}{2} - 1)$
- (vi) Crown Distance (JH) = $R - R \cdot \cos \frac{\Delta}{2} = R \cdot (1 - \cos \frac{\Delta}{2})$ = $(R \cdot \text{Vers } \frac{\Delta}{2})$
- (vii) Long chord (AB) = $2R \cdot \sin \frac{\Delta}{2}$
- (viii) Chord (AS) = $2R \cdot \sin \delta$

8.3 Laying Out of Circular Curves

- Lay out principal points - TP_1 , IP and TP_2 .
- Lay out midpoint of curve, the crown (H), if required. Measuring from the IP to the crown, the crown secant distance, is a good check.
- Peg out centre line of a circular curve by:
 - ✓ Deflection angles and chords – will be covered in this Chapter, workshop and practicals.
 - ✓ Tangent offsets (Uren & Price, p602)
 - ✓ Chord offsets (Uren & Price, p608)
 - ✓ Radiations using coordinates (Uren & Price, p610)

Setting steps using deflection angle and chord method (Figure 8.14):

- 1 Set up Total Station at TP₁
- 2 Point to intersection Point, - IP, and set horizontal direction to zero [0 SET].
- 3 Turn deflection angle of 1st point, measure and mark chord length, $\ell_1 = 2R\sin\delta_1$.
- 4 Turn deflection angle of 2nd point, measure and mark chord length, $\ell_2 = 2R\sin\delta_2$.
- 5 Continue until you reach TP₂.

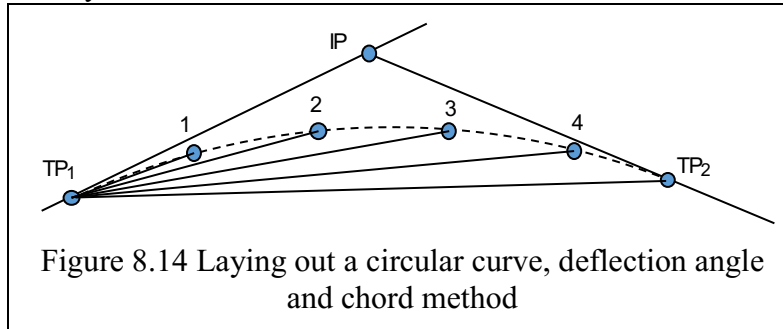
**Checks – Deflection/Chord Method**

- ✓ Carry out visual check - does the curve look right.
- ✓ Measure distance to midpoint of curve, the crown, and TP₂.
- ✓ Measuring deflection angle to midpoint of curve, the crown, and TP₂.
- ✓ Measuring distances between individual pegged points. The in, through, and out chords.
- ✓ Check radii to the pegged points, if the centre point is accessible.
- ✓ Repeat pegging from TP₂. - pegs should be at the same points to those from TP₁.

Setting steps using coordinates method (Figure 8.15):

- 1 Calculations - Determine the coordinates of all the points to be pegged – TP₁, TP₂, IP, crown and all chainage points.
- 2 Set Total Station on any known coordinated control point, CP₁, and back sight to the second coordinated control point, CP₂.
- 3 Set BS bearing, [H.ANG], in the Total Station.
- 4 Calculate the bearing and distance to each point on the curve to be pegged from CP₁.
- 5 Turn off bearing and measure distance to each point on the curve to be pegged.

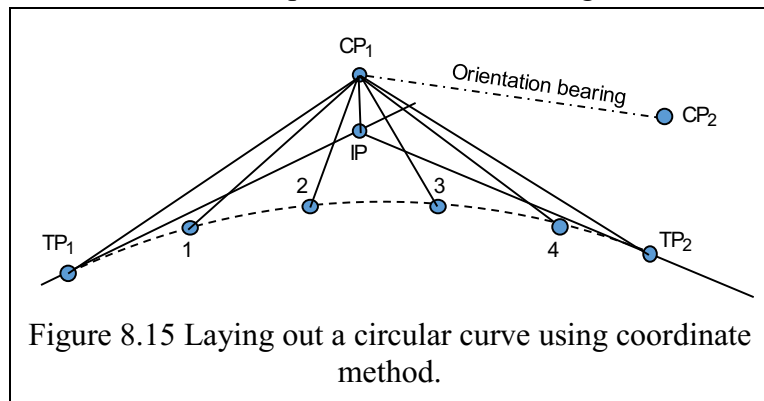
**Checks – Coordinates Method**

- ✓ Measure bearing and distance to third control point - check on control points.
- ✓ Carry out visual check - does the curve look right.
- ✓ Measuring distances between individual pegged points. The in, through, and out chords.
- ✓ Check radii to the pegged points, if the centre point is accessible.
- ✓ Repeat pegging from a second control point - pegs should agree.

You are assigned curve M1 left shoulder kerb, $s = 11$, you will have to derive YOUR parameters:

deflection angle, $\Delta = 50^\circ$
 radius = CL radius \pm (width/2)
 $= 25 + 5.5$
 (curve turns right, centre is to right radius increases)

$R = 30.5$

$CH_{PC} = 63.5$

(the centre is perpendicular to the tangent point, all chainages are the same)

$PC\ E = CL\ E \pm (width/2)$

$= 1000.00 - 5.5$

(curve turns right, centre is to right, E decreases)

$PC\ E = 994.5$

$PC\ N = CL\ N = 1000.00$

(Brg IP = 360° , so, no N offset due to bearing or formation (width/2 distance).

Figure 8.18 shows the different chainages at the PT and the Easting coordinates of the PC.

The coordinates of the formation IP are then:

$IP\ E = PC\ E = 994.5 = 994.50E$

(Brg = 360° , straight N of PCE)

$TD = R \cdot \tan(\Delta/2) = 30.5 \tan(25) = 14.22$

$IP\ N = PC\ N + TD$

$= 1000.00 + 14.22 = 1014.22N$

Arc length, $S = R \cdot \Delta^{\text{radians}}$

$= 30.5 \cdot (50 \cdot \pi / 180)$

$= 30.5 \times 0.8727 = 26.616,$

and thus,

CH_{PT} (right formation) $CH_{PC} + S$

$= 63.5 + 26.62 = 90.116$

(End of curve.)

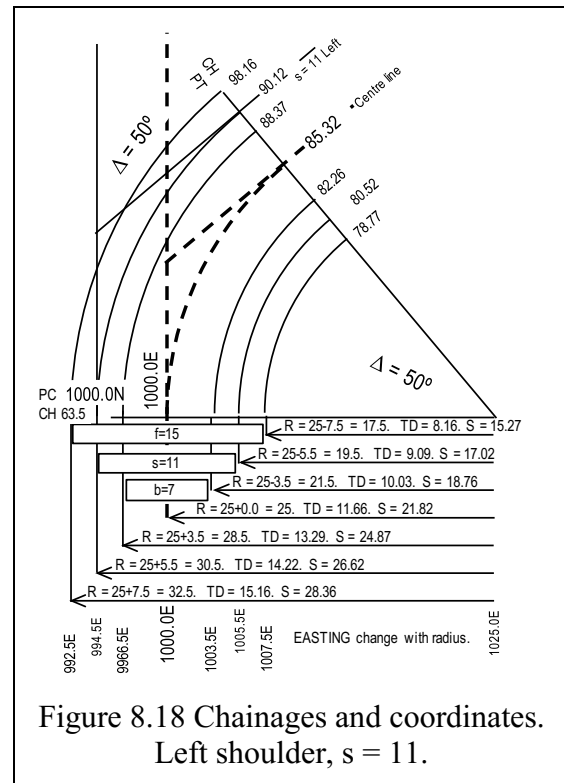
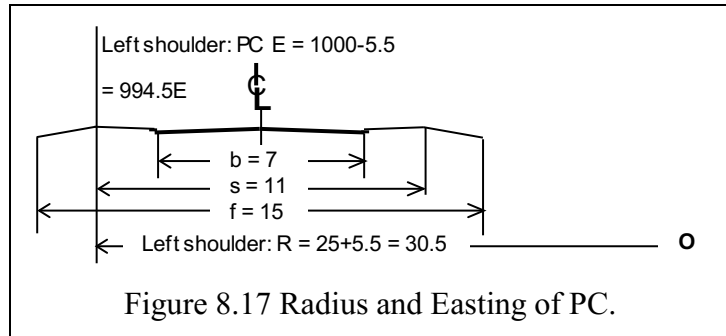

In many cases, you will be given the coordinates and chainage of the IP, the deflection angle, Δ , and the radius, R, on the design centreline.

Calculate backwards to find the coordinates of the point of curvature, PC, and chainage of the PC.

- Calculate the tangent distance, TD and subtract it from the CH_{IP} :
 - $CH_{PC} = CH_{IP} - TD$.
- Reverse the bearing to the IP,
 - use the TD to calculate the rectangular coordinate differences, dE and dN.

These coordinate differences, added to the IP coordinates, result in the coordinates of the PC.

8.4.3 Initial Curve Calculations

From your allocated curve, there are some parameters that you will have to deduce and calculate, as follows:

Curve M1, centre line calculations.

Based on **CENTRE LINE** calculations, centre line offset = 0

Initial direction of tangent	360°	
Chainage & coords of PC (TP1) =	Ch 63.5	E1000.000 N1000.000
Radius	R = 25	
Design deflection angle Δ	$\Delta = 50$	
Through chainage interval	s = 5	
Arc length, $S = R \cdot \Delta^{\text{radians}}$	= 21.817	
Design TD = $R \tan(\Delta/2)$	= 14.222	
Long chord = $2R \sin(\Delta/2)$	= 21.131	
Secant distance = $R/\cos(\Delta/2)$	= 27.584	
Crown secant = $R/\cos(\Delta/2) - R$	= 27.584 - 25	= 2.584
Crown distance = $R - R \cos(\Delta/2)$	= 25 - 22.658	= 2.342
CH PT = CH PC + S	= 63.5 + 21.817	= 85.317
CH Crown = CH PC + S/2	= 63.5 + 21.817/2	= 74.408
CH IP = CH PC + TD	= 63.5 + 14.222	= 77.722
E coordinates of IP, E IP +dE	= 1000.000 + 0.000	= E1000.000.
N coordinates of IP, N IP +dN	= 1000.000 + 14.222	= N1014.222.

With the parameters calculated it is time to create a table of values. Note that the chainage of the PC is 63.5; the through chainage is 5m and the calculated table must reflect this specification:

Remember that the centre deflection angle (2δ) = arc length(s)/radius(R) is evaluated in **radians** and has to be converted to an angle in **degrees**. The **chord deflection angle** (δ) is **half** the centre deflection angle. Table 8-2 shows the centre deflection angle in radians, chord deflection in degrees.

The bearing of the IP is 360°, so the chord deflection angle becomes the bearing to each chainage point. In the field, it may be necessary to add the chord deflection angles to a nominated bearing before calculating the coordinates of the chainage points. Bearing (θ) = Initial Brg + δ .

$$\text{The chord length } \ell = 2R \cdot \sin(\delta). \quad dE = \ell \sin(\theta), \quad dN = \ell \cos(\theta).$$

Note: Chainage coordinates **radiate** from the PC coordinates.

$$(\text{Ch E} = \text{PC E} + dE, \text{Ch N} = \text{PC N} + dN).$$

Table 8-2 Set-out for curve M1, centre line.

Point	Ch	s	$2\delta^R$	δ°	$\delta^\circ(\text{DMS})$	ℓ chord	dE	dN	E	N
CH _{PC}	63.50	0.00	0.000	0.000		0.00	0.0	0.0	1000.00	1000.00
CH	65.00	1.50	0.0600	1.719	1° 43' 07"	1.50	0.04	1.50	1000.04	1001.50
CH	70.00	6.50	0.2600	7.448	7° 26' 54"	6.48	0.84	6.43	1000.84	1006.43
CH	75.00	11.50	0.4600	13.178	13° 10' 40"	11.40	2.60	11.10	1002.60	1011.10
CH	80.00	16.50	0.6600	18.908	18° 54' 27"	16.20	5.25	15.33	1005.25	1015.33
CH	85.00	21.50	0.8600	24.637	24° 38' 13"	20.84	8.69	18.95	1008.69	1018.95
CH _{PT}	85.32	21.82	0.8728	25.000	25° 00' 00"	21.13	8.93	19.15	1008.93	1019.15

8.4.4 In, Through and Out arcs for Curve M1

Referring to Section 8.2.6, and Table 8-2, the following are the three arcs for radius, $R=25\text{m}$:

In arc	=	1.5	$2\delta^\circ = 0.0600$	$\delta^\circ = 1^\circ 43' 07''$	ℓ chord = 1.500
Ch interval	=	5	$2\delta^\circ = 0.2000$	$\delta^\circ = 5^\circ 43' 47''$	ℓ chord = 4.992
Out arc	=	0.317	$2\delta^\circ = 0.0128$	$\delta^\circ = 0^\circ 22' 00''$	ℓ chord = 0.317

8.5 Roads in Mining Operations

Properly designed and well maintained roads are a vital part of safe and efficient mining operations. The machinery is BIG, with some tipper trucks now spreading up to 10 metres width. Two-way traffic around a bend calls for pavement widths of 40 metres, formation widths of 60 metres, and inside radius of about 100 metres. Gradients must be constant; this may put an extra layer of complexity on curve design.

8.5.1 Haul Road Example

The example of a mining haul road curve (Section 8.5.2) shows larger radius curves, longer through chainages and increased formation and pavement widths, Figure 8.19.

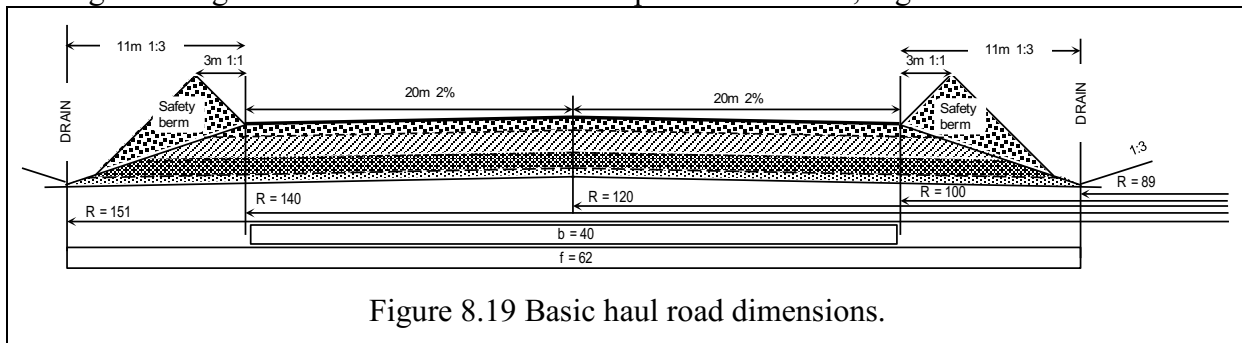

Figure 8.19 Basic haul road dimensions.

From your allocated curve, these are some of the parameters you will have to deduce and calculate as follows:

8.5.2 Curve T5, centre line calculations.

Based on **CENTRE LINE** calculations, centre line offset = 0

Initial direction of tangent	360°	
Chainage & coords of PC (TP1) =	Ch 211.00	E994.000 N3111.000
Radius	R = 105	
Design deflection angle Δ	$\Delta = 81$	
Through chainage interval	s = 25	
Arc length, $S = R \cdot \Delta^{\text{radians}}$	= 148.440	
Design TD = $R \tan(\Delta/2)$	= 89.678	
Long chord = $2R \sin(\Delta/2)$	= 136.384	
Secant distance = $R/\cos(\Delta/2)$	= 138.084	
Crown secant = $R/\cos(\Delta/2) - R$	= 138.084 - 105	= 30.084
Crown distance = $R - R \cos(\Delta/2)$	= 105 - 79.843	= 25.157
CH PT = CH PC + S	= 211 + 148.440	= 359.440
CH Crown = CH PC + S/2	= 211 + 148.44/2	= 285.220
CH IP = CH PC + TD	= 211 + 89.678	= 300.678
E coordinates of IP, E IP +dE	= 994.000 + 0.000	= E994.000
N coordinates of IP, N IP +dN	= 3111.000 + 89.678	= N3200.678

With the parameters calculated it is time to create a table of values. Note that the chainage of the PC is 211, that the through chainage is 25m and the table must reflect this specification: Remember that the centre deflection angle (2δ) = arc length(s)/radius(R) is evaluated in **radians** and has to be converted to an angle in **degrees**. The **chord deflection angle** (δ) is **half** the centre deflection angle. Table 8-3 shows the centre deflection angle in radians, chord deflection in degrees.

The bearing of the IP is 360° , so the chord deflection angle becomes the bearing to each chainage point. In the field, it may be necessary to add the chord deflection angles to a nominated bearing before calculating the coordinates of the chainage points.

$$\text{Brg}(\theta) = \text{Initial Brg} + \delta.$$

8.5.2.1 Set-Out Table for Curve T5

The chord length $\ell = 2R \cdot \sin(\delta)$. $dE = \ell \sin(\theta)$, $dN = \ell \cos(\theta)$.

Note: Chainage coordinates **radiate** from the PC coordinates.

$$(\text{Ch E} = \text{PC E} + dE, \text{Ch N} = \text{PC N} + dN).$$

Table 8-3 Set-out for curve T5, centre line.										
Point	Ch	s	$2\delta^R$	δ°	$\delta^\circ(\text{DMS})$	ℓ chord	dE	dN	E	N
CH _{PC}	211.00	0.00	0.000	0.000		0.00	0.0	0.0	994.00	3111.00
CH	225.00	14.00	0.1333	3.820	3° 49' 10"	13.99	0.93	13.96	994.93	3124.56
CH	250.00	39.00	0.3714	10.641	10° 38' 26"	38.78	7.16	38.11	1001.16	3149.11
CH	275.00	64.00	0.6095	14.462	17° 27' 41"	63.01	18.91	60.11	1012.91	3171.11
CH	300.00	89.00	0.8476	24.282	24° 16' 56"	86.36	35.51	78.92	1029.51	3189.72
CH	325.00	114.00	1.0857	31.103	31° 06' 12"	108.48	56.04	92.89	1050.04	3203.89
CH	350.00	139.00	1.3238	37.924	37° 55' 27"	129.07	79.33	101.81	1073.33	3212.81
CH _{PT}	359.44	148.44	1.4137	41.500	41° 30' 00"	136.38	88.57	103.71	1082.57	3214.71

8.5.2.2 In, Through and Out Arcs for Curve T5

Referring to Section 8.2.6, and Table 8-3, the following are the three arcs for radius, R=105m:

In arc	= 14	$2\delta^R = 0.1333$	$\delta^\circ = 3^\circ 49' 10''$	ℓ chord = 13.990
Ch interval	= 25	$2\delta^R = 0.2381$	$\delta^\circ = 6^\circ 49' 15''$	ℓ chord = 24.941
Out arc	= 9.44	$2\delta^R = 0.0899$	$\delta^\circ = 2^\circ 34' 32''$	ℓ chord = 9.437

8.5.2.3 Resulting Tangent and Arc Distances for the T5 Formation

Note that the radii involved in the four other calculations, with, for example, formation width **f** = 62 and pavement width **b** = 40 are:

Left formation:	105 + 31	= 136	TD = 116.15	Arc, S = 192.26
Left pavement:	105 + 20	= 125	TD = 106.76	Arc, S = 176.11
Centreline:	105 + 0	= 105	TD = 89.68	Arc, S = 148.44
Right formation:	105 - 20	= 85	TD = 72.60	Arc, S = 120.16
Right pavement:	105 - 31	= 74	TD = 63.20	Arc, S = 104.62

8.6 Concluding remarks

It is essential for the students to know at what point the horizontal alignment (circular curve) starts, its length and where it ends. Basic circular geometrical properties (tangency, chord, radius and subtended angles) are the employed in the design stage. Chainages (road length

intervals from some starting point) to the IP (intersection point of the straights), the end of the circular curve and the chainage intervals along the circular curve will always be specified for the given horizontal alignment. With these parameters, the chainage of the start of the curve, plus the length of the curve, can be computed. This is followed by the ingoing, through and outgoing arc lengths, plus their deflection angles and chords required for the actual setting out. A table of chords and deflection angles is then tabulated. It should be pointed out that other methods (i.e., coordinates approach) could be used in setting out of the horizontal alignments. However, these coordinates themselves are generated from initial beating, deflection angles and chord distances. This chapter has synthesised these materials in a manner that we hope will be easier for the students to follow and understand.

8.7 References to Chapter 8

1. Uren and Price (2006, 2010) *Surveying for engineers*. Fourth edition, Palgrave Macmillan, Chaps 12.
2. Schofield and Breach (2007) *Engineering Surveying*. Sixth edition, Elsevier, Chap. 10.
3. Irvine and Maclellan (2006) *Surveying for Construction*. Fifth edition, McGraw, Chap. 11

Chapter 9 Vertical Curves

9.1 Introductory Remarks

At the end of this Chapter and exercise 6 (Appendix A2-5), you should:

- ✓ Understand and appreciate the geometric properties of a vertical curve.
- ✓ Understand what gradients are and the limitations that are imposed on their values.
- ✓ Appreciate the role of vertical curves in improving safety and comfort of passengers travelling from one intersecting gradient to another.
- ✓ Be able to design a vertical curve.

Exercise 6 involves calculating the volume occupied by a series of vertical curves through modelled terrain.

9.1.1 Definition

The vertical curve, Figure 9.1, is a curve joining two different grades (or gradients) in a vertical profile. The purpose of the curve is to smooth the passage from one gradient to another.

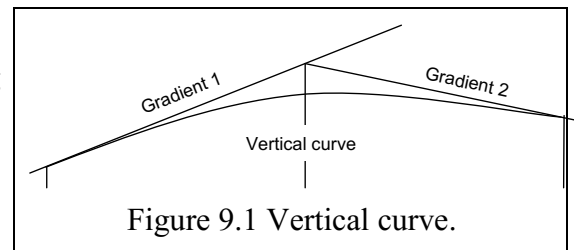

9.1.2 Uses

- Introduced between two intersecting gradients to smooth the passage from one gradient to another in the vertical plane.
- A vehicle travelling along a vertical curve experiences a radial force that tries to force the vehicle from the centre of curvature of the vertical curve. This forces the vehicle to leave the road in case of a crest design, while the vehicles could come into contact with a road surface for a sag design. Both result in discomfort and danger to passengers and are minimized through restricting the gradients and choosing a suitable type and length of curve.
- Adequate visibility: Vertical curves enables vehicles travelling at a given design speed to stop or overtake safely.
- Considerations include safety, riding comfort and sight distance.

9.1.3 Components of a Vertical Curve

The **gradient** or grade of a slope is expressed as a **percentage**. A slope is expressed as a ratio of **vertical** to **horizontal**, generally 1: n.

The gradient of a slope of 1 vertical in 20 horizontal (1:20)
 $= 1/20 = 0.05 = 5\%$, i.e.,

Gradient = 5m vertical for every 100m horizontal (see Figure 9.2).

The slope **angle** = arctangent (slope). $1:20 = 0.05 = \text{atan}(0.05) = 2.862^\circ = 2^\circ 52'$.

A rising gradient in the direction of the running chainage is positive gradient $+g_1\%$ while a falling gradient in the direction of the running chainage is negative gradient $-g_2\%$. See Figure 9.3.

In road design a vertical curve is generally a **parabolic** curve in the longitudinal profile of the carriage-way to provide a change of grade at a specified vertical acceleration. In developing examples of the vertical curve the design criteria used is that which is published in Austroads, 2003.

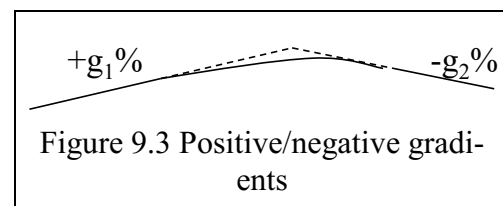
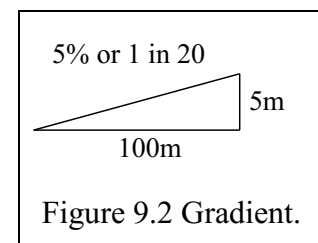

9.2 Elements of the Vertical Curve

Two gradients intersect at a point V, the Point of Intersection (PI). The gradients are **tangential** to a parabolic section running from the initial Point of Curvature (PC) to the final Point of Tangency (PT).

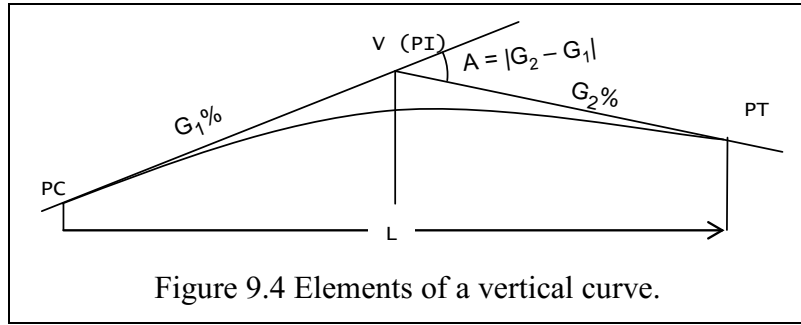

Figure 9.4 Elements of a vertical curve.

Notations: (Figure 9.4)

- G_1 Initial gradient, expressed as a percentage
- G_2 succeeding gradient, expressed as a percentage
- V or PI Vertex or Point of Intersection
- PC Point of Curvature, the start of the curve
- PT Point of Tangency, the end of the curve
- L Length of the curve. It is measured **horizontally** in units of 100m.
 A vertical curve with a horizontal distance of 350m has $L=3.5$.
 The arc length of the parabola can be found by summing the chord lengths between pegging stations.
- A Gradient difference.

Two properties of a parabola:

Figure 9.5 shows the **first** of two properties of a parabola. The horizontal projections of the tangents at PC and PT are equal. They are equal to half the horizontal projection of the curve, i.e., $\frac{1}{2}L$.

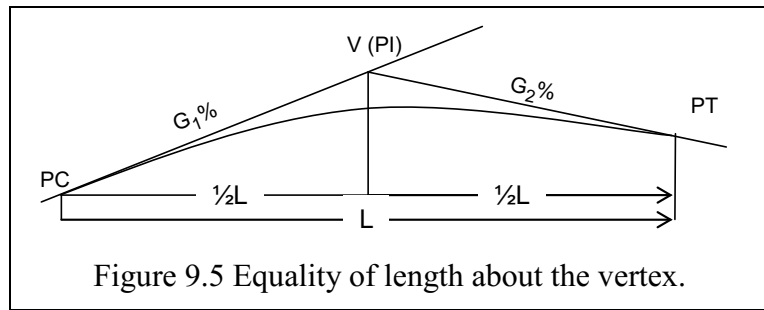

Figure 9.5 Equality of length about the vertex.

The **second** property is that the rate of change of grade of the curve is constant. Thus, the gradient at any point along the parabola can be expressed using the horizontal length of the curve.

$$r\% = \frac{G_2 - G_1}{L}, \text{ where } r\% \text{ can be read as } r \text{ "percent per 100"} \tag{9.1}$$

Figure 9.6 shows a curve between two grades, $G_1 = +5\%$, $G_2 = -4\%$, joining a parabolic curve of length = 300m. $L = 3$. Find r.

From Equation 9.1:

$$r\% = \frac{(-4) - (+5)}{3} = -3\%.$$

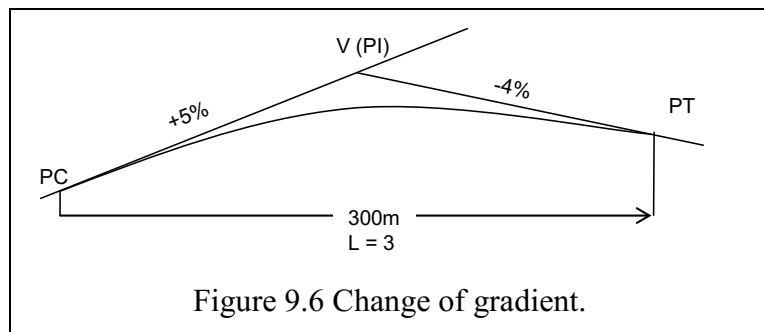

Figure 9.6 Change of gradient.

To find the gradient of the curve at PC + 100 where: (Figure 9.7)
 final gradient = Initial gradient + gradient change.

At PC + 100: $L = 1, r = -3$
 $G_{100} = 5 + (-3 \cdot 1)$
 $= 2\%$

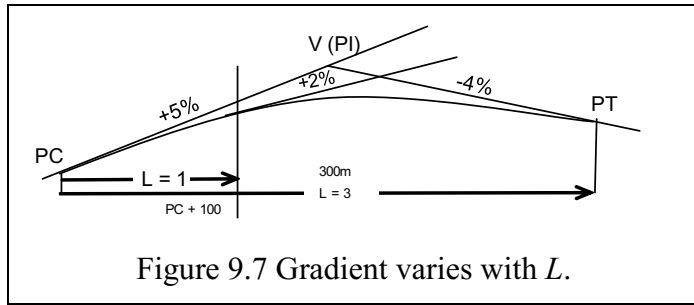

Figure 9.7 Gradient varies with L.

9.2.1 Sign of r.

If $r > 0$ (positive) = sag curve

If $r < 0$ (negative) = crest curve

If the signs of G_1 and G_2 are **opposite** then there will be a high or low point. (Figure 9.8)

If G_1 and G_2 are numerically equal, but opposite sign, then the high or low point will be at the midpoint. Otherwise it must be calculated.

Crest curves, Figure 9.9, occur when the succeeding gradient is less than the initial gradient.

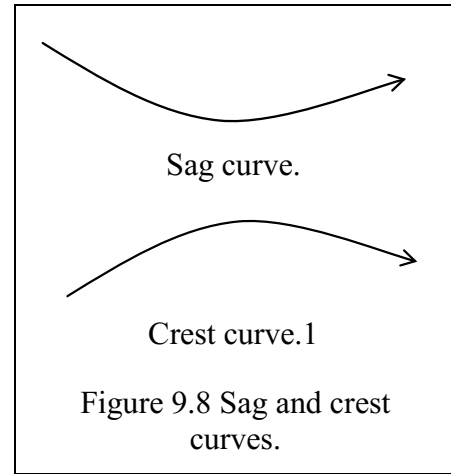

Figure 9.8 Sag and crest curves.

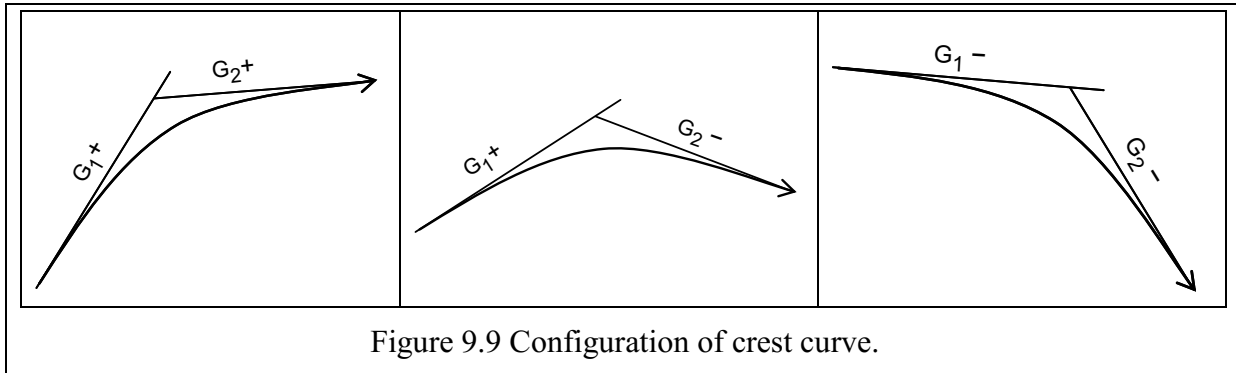

Figure 9.9 Configuration of crest curve.

Sag curves, Figure 9.10, occur when the succeeding gradient is greater than the initial gradient.

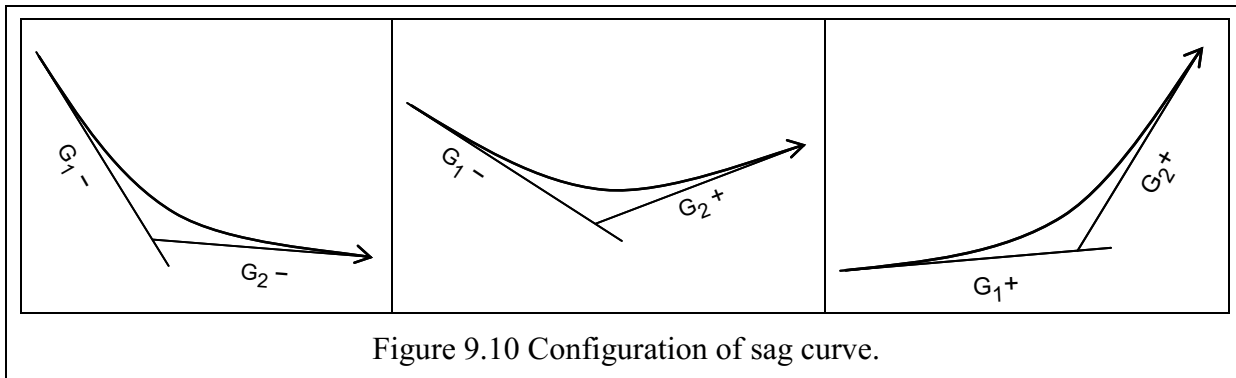

Figure 9.10 Configuration of sag curve.

9.3 Calculus of the Parabola

The parabola is a conic curve of a second-degree equation. If there is no xy term in the expression, then the principal axis is either horizontal, $y = \pm kx^2$ or vertical, $x = \pm ky^2$. The shape, or rate of change of gradient, is given by the constant, k .

The general form of the parabola, with its principal axis parallel to the vertical axis is

$$\boxed{y = ax^2 + bx + c} \quad (9.2)$$

This equation will be developed to enable calculation of the vertical coordinates, the RLs, of points on the curve.

Reference Figure 9.11, y will be the RL of any point on the curve at a horizontal distance, x , from the PC.

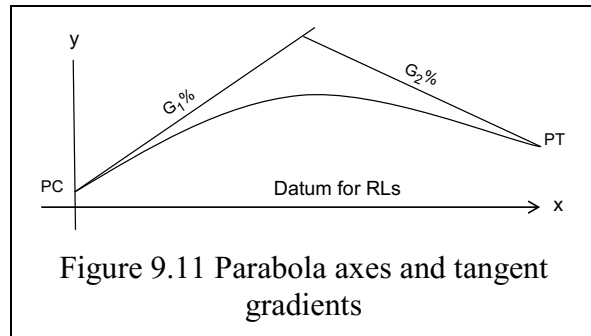

9.3.1 Developing the General Equation

Convert the general equation: $y = ax^2 + bx + c$ into an expression covered by the elements of the vertical curve.

1. Find the value of y at $x = 0$

$$\boxed{y = c = RL \text{ of } PC} \quad (9.3)$$

2. The first derivative of Equation 9.2 provides the gradient:

$$\frac{dy}{dx} = 2ax + b, \text{ and again}$$

$$\text{When } x = 0, \frac{dy}{dx} = b \text{ i.e.:$$

$$b = \text{gradient of curve when } x = 0$$

$$\boxed{b = G_1}$$

3. The second derivative of Equation 9.2 of a curve provides the rate of change of grade:

$$\frac{d^2y}{d^2x} = 2a.$$

We have defined r as the rate of change of gradient. Thus:

$$\boxed{r = 2a \text{ or } a = \frac{1}{2}r} \quad (9.4)$$

4. Substitute derived constants into Equation 9.2 gives the expression:

$$\boxed{y = \frac{1}{2}rx^2 + G_1x + RL_{PC}} \quad (9.5)$$

9.3.2 Deriving Data from the General Equation

The general parabolic equation, 9.2, for the vertical curve is expressed in terms related to the design of the curve (i.e., Equation 9.5)

$$y = \frac{1}{2}rx^2 + G_1x + RL_{PC} \text{ where}$$

r = rate of change of gradient (as percent per 100)

G_1 = initial gradient of slope (as a percentage)

RL_{PC} = RL of Point of Curvature, at the start of vertical curve.

9.3.3 High or Low Point of the Vertical Curve

The high/low point of the curve is the point at which the gradient of the curve is zero.

Find the value of x where slope = 0

Take first derivative, using Equation 9.5, $\frac{dy}{dx} = rx + G_1$

Gradient is zero when $\frac{dy}{dx} = 0$, i.e.,

$$rx + G_1 = 0$$

$$x = \frac{-G_1}{r}$$

(9.6)

where x = distance from PC in units of 100.

$$\text{Chainage high/low point} = \text{Chainage PC} + 100 \cdot \frac{-G_1}{r} \tag{9.6a}$$

Note: If the high/low point is on the parabola between the PC and PT then

$\frac{-G_1}{r}$ will be positive because G_1 and r will be opposite signs.

Taking the vertical curve in Figure 9.6 as an example, remember G_1 is negative:

$$r = -3$$

$$G_1 = 5$$

$$x = \frac{-5}{-3} = 1.67, \text{ the chainage of the high point is thus:}$$

$$\text{CH}_{PC} + 100x = \text{CH}_{PC} + 167.$$

9.3.4 Level of High or Low Point of the Vertical Curve

The height (Δh) of the high/low point of the curve is the product of the distance at which the gradient of the curve is zero, x and gradient of the line AP.

Line AP is parallel to the tangent through the mean point of the parabola AP. The gradient of the curve at the mean point will be the mean of the gradients at the end points, A and, in this case, P, where the gradient is zero.

Examine the gradients:

$$\text{Gradient at A} = G_1$$

$$\text{Gradient at P} = 0$$

$$\text{Gradient AP} = \frac{1}{2}(G_1 + 0) = \frac{1}{2}G_1$$

$$\Delta h = \frac{1}{2}G_1x \tag{9.7}$$

$$\text{RL}_P = \text{RL}_{PC} + \frac{1}{2}G_1x \tag{9.7a}$$

The RL of the low point will use the same formula because G_1 is negative.

It can also be seen that, substituting x from Equation 9.6:

$$\Delta h = \frac{-\frac{1}{2}G_1^2}{r} \tag{9.8}$$

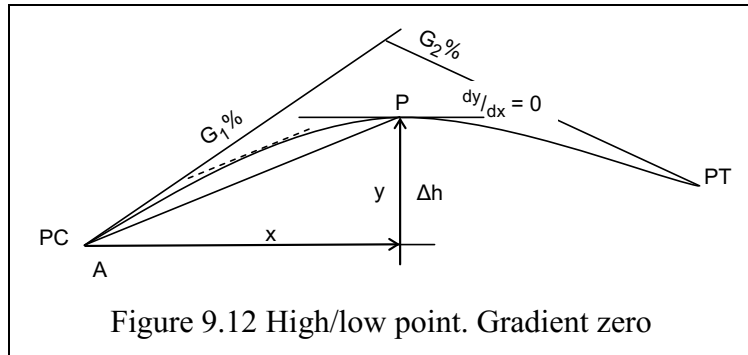

Figure 9.12 High/low point. Gradient zero

Worked Example 9.1

Two intersecting profile gradients consist of a +5% gradient meeting a -3% gradient.

They are to be joined by a parabolic vertical curve 200m long.
 $L = 2$.

Chainage of the PC = 1400m,
 RL PC = 299m.

Calculate the chainage and RL of the highest point.

1. Calculate $r\%$ using Equation 9.1:

$$r = \frac{G_2 - G_1}{L} = \frac{-3 - (+5)}{2} = -4$$

2. Chainage to high point, P: (Equation 9.6): $x = \frac{-G_1}{r} = \frac{-5}{-4} = 1.25, = 125\text{m}.$

Chainage P = $CH_{PC} + x = 1400 + 125 = \mathbf{1525\text{m}}.$

3. Δh of high point, P: (Equation 9.7): $\Delta h = \frac{1}{2}G_1x = \frac{1}{2} \cdot 5 \cdot 1.25 = 3.125\text{m}.$

RL of high point, P = $RL_P + \Delta h = 299 + 3.125 = \mathbf{302.125\text{m}}.$

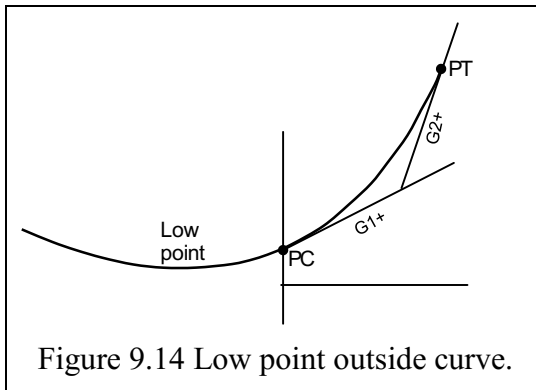
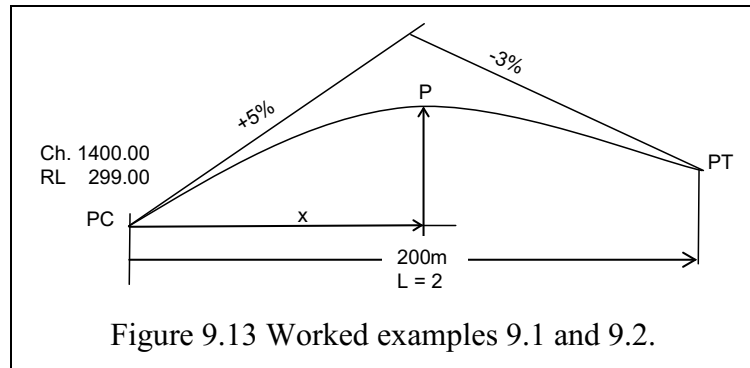

Note that the high/low point of the parabola ($\frac{dy}{dx} = 0$) may not occur on the section of parabola under investigation (see Figure 9.14).

9.3.5 The Midpoint of the Vertical Curve

The “external” distance, e , is the vertical distance from the vertex, or point of intersection, of the two gradients to the midpoint of the curve. In Figure 9.15, the gradient G_1 has been produced to point C vertically above the PT.

Horizontal distance PC to PT = L (units of 100).

Angle A is the algebraic change of grade.

$$A = |G_2 - G_1|$$

N is the midpoint of the chord PC to PT, and is vertically below V.

Note that, if $|G_1| = |G_2|$ then M is the high point, P, as in Figure 9.15

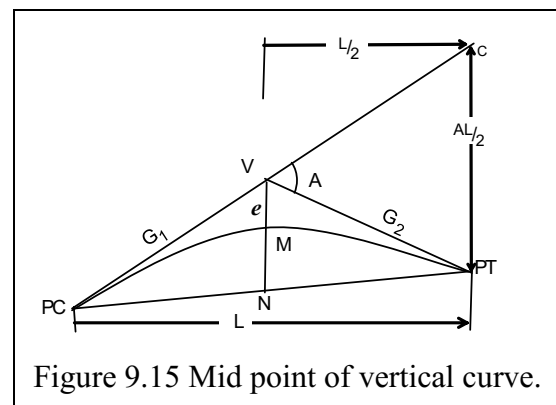

- The Δh of the PT with reference to PC = $\Delta h(\text{PC to V}) - \Delta h(\text{V to PT})$
remember that G_2 is negative
 $\Delta h_{\text{PC-PT}} = \frac{1}{2}(G_1L) + \frac{1}{2}(G_2L) = \frac{1}{2}(G_1 + G_2)L$.
- It follows that Δh between C and PT
= $\Delta h(\text{PC to C}) - \Delta h(\text{PC to PT})$
= $G_1L - \frac{1}{2}(G_1 + G_2)L = \frac{1}{2}(G_1 - G_2)L$, but $G_1 - G_2 = |G_2 - G_1| = A$
= $\frac{1}{2}AL$ or $\frac{AL}{2}$.
- Similarly: $\text{VN} = \Delta h(\text{PC to V}) - \Delta h(\text{PC to N})$
= $\frac{1}{2}G_1L - \frac{1}{2}(\frac{1}{2}(G_1 + G_2)L)$
= $\frac{1}{4}(G_1 - G_2)L$
= $\frac{1}{4}AL$ or $\frac{AL}{4}$.

One of the properties of the parabola is:

Offsets from the tangent vary with the square of the distance from the PC.

In general terms: $e = \left(\frac{n}{m}\right)^2 \cdot \frac{AL}{2}$ and $\frac{AL}{2}$ is a constant for the curve.

The offset to V from the tangent at M (this is e), which is $\frac{1}{2}L$ from the PC

$$h_{\text{VM}} = e = \left(\frac{1}{2}\right)^2 L \cdot \frac{A}{2} = \frac{1}{4}L \cdot \frac{A}{2} = \frac{AL}{8}$$

This shows that $e = \frac{1}{2}$ the difference between the RL of V and the RL of N.

Using the squared offset method, a number of other “ e ” values can be found such that, if L is the length of the curve:

$$\text{for } \frac{1}{4}L: \quad e = \frac{1}{16} \cdot \frac{AL}{2}$$

$$\text{for } \frac{3}{4}L: \quad e = \frac{9}{16} \cdot \frac{AL}{2}$$

Worked Example 9.2

Two intersecting profile gradients consist of a +5% gradient meeting a –3% gradient. They are to be joined by a parabolic vertical curve 200m long. (Figure 9.16).

Find the offset, e , from the initial gradient G_1 at the midpoint and also the $\frac{1}{4}$ and $\frac{3}{4}$ point of length of the curve.

From worked example 9.1:

$$L = 200$$

$$G_1 = +5$$

$$G_2 = -3$$

$$A = |G_2 - G_1| = 8$$

$$\frac{AL}{2} = 80$$

$$e_{\text{midpoint}} = \frac{1}{4} \cdot \frac{AL}{2} = \frac{AL}{8} = \frac{2 \cdot 80}{8} = 20$$

$$e_{\frac{1}{4}} = \frac{1}{16} \cdot \frac{AL}{2} = \frac{1}{16} \cdot 80 = 5$$

$$e_{\frac{3}{4}} = \frac{9}{16} \cdot \frac{AL}{2} = \frac{9}{16} \cdot 80 = 45$$

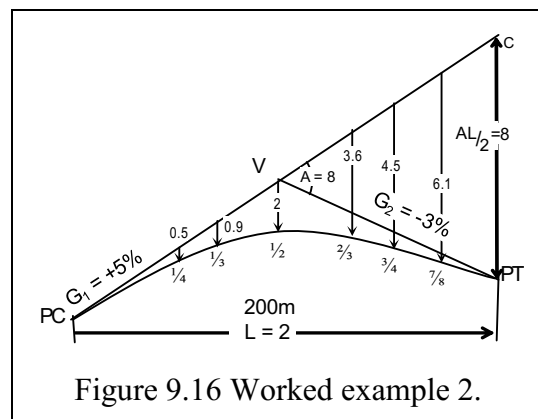

Figure 9.16 Worked example 2.

Similarly, the offset from the initial gradient can be found at any portion of the length of the parabola once $\frac{AL}{2}$ has been evaluated.

e.g. $e \frac{1}{3} = \frac{1}{9} \cdot 8 = 0.89$

$$e \frac{2}{3} = \frac{4}{9} \cdot 8 = 3.56.$$

The technique has limited application compared with modern calculation methods, but the midpoint value of $e = \frac{AL}{8}$ is a handy check of the calculation.

9.3.6 Pass a Curve Through a Fixed Point

It is often necessary to have a curve pass through a fixed point when two gradients are being joined. A practical example is the requirement to provide a certain amount of “clearance” below an overpass, or a bridge.

The task may be to find the **length** of the parabola joining two designated grades.

Or it may be necessary to find the **gradient** of the succeeding gradient if the length of the parabola is fixed.

The governing variable in these cases is the value r , the rate of change of gradient ($r\%$), used in the parabolic formula:

$$y = \frac{1}{2}rx^2 + G_1x + RL_{PC}, \text{ (Equation 9.5), where } r = \frac{G_2 - G_1}{L} \text{ and } x \text{ is units of 100.}$$

Worked Example 9.3

A road is to be redesigned using a parabolic vertical curve to provide clearance beneath a bridge (see Figure 9.17).

The PC has chainage 1140.00m, with an RL of 125.604m.

The initial gradient, $G_1 = -4\%$.

A bridge at chainage 1300.00 has an RL = 128.5m at its lowest point.

You must provide **4.5m** clearance from the underside of the bridge, and the parabola will finish with a succeeding gradient, $G_2 = +3.6\%$.

What is the length of the curve?

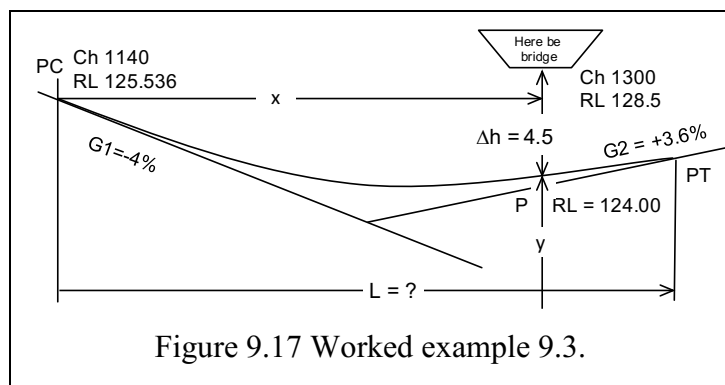

Figure 9.17 Worked example 9.3.

Formula of vertical curve: (Equation 9.5), $y = \frac{1}{2}rx^2 + G_1x + RL_{PC}$,

Data: $x = (1300 - 1140)/100 = 1.6$ (units of 100 to allow for grade %)

$y = 128.5 - 4.5 = 124.0$ (RL of clearance)

$RL_{PC} = 125.536$

$G_1 = -4\%$

$G_2 = +3.6\%$

Using the formula of vertical curve above, find $r\%$: to allow calculation of L

$$124.0 = \frac{1}{2}r \cdot (1.6)^2 + (-4 \cdot 1.6) + 125.536$$

$$r = \frac{2(124 + 6.4 - 125.536)}{1.6^2} = 3.8$$

$$\text{But: } r = \frac{G_2 - G_1}{L}$$

$$\text{thus } L = \frac{G_2 - G_1}{r} = \frac{3.6 - (-4)}{3.8} = 2.0 \text{ units of } 100.$$

$$\text{Length of curve} = L \times 100 = \mathbf{200\text{m}}$$

9.4 Calculate the RLs of Points Along the Vertical Curve

Once a vertical curve has been designed it is necessary to generate a tabulated list of RL at intermediate stations. As with the horizontal curve, they will most likely be at regular whole number chainages. Remember that for the vertical curve, we measure the chainages horizontally from the PC.

A constant pegging interval allows a check of the calculations to be performed using the second difference between RLs.

The first difference (Δ) is the difference between successive RLs. The second difference (Δ'') is the difference between successive first differences, the Δ 's. As the parabola is a second-degree equation the Δ'' must be constant for a constant interval.

The first and second differences can be tabulated in the pegging data.

Chord length can be tabulated to find approximate arc length.

9.4.1 Worked Example. Single Vertical Curve

Figure 9.17 (previous page) shows the design of a vertical curve to be pegged at 20m intervals from the PC to the PT over a length of 200m.

Using the vertical curve in Worked example 9.3, and Figure 9.18 for visualisation:

Tabulate the RLs, show the second difference similarities.

Find the chainage and RL for the low point. Use chords to find arc length.

$$\text{Ch PC} = 1140.00\text{m},$$

$$\text{RL PC} = 125.536\text{m}.$$

$$\text{Ch PT} = 1340.00\text{m}.$$

$$G_1 = -4\%$$

$$G_2 = +3.6\%.$$

$$L = 2.0,$$

$$r = (G_2 - G_1)/L$$

$$= (3.6 - (-4))/2$$

$$r = +3.8 \text{ (sag curve).}$$

Create the formula for the curve in terms of x from:

$$x = 0, 0.2, 0.4, \dots, 1.8, 2:$$

$$\text{RL}_{\text{Ch}} = \frac{1}{2}rx^2 + G_1x + \text{RL}_{\text{PC}} = 1.9x^2 - 4x + 125.536.$$

Table 9-1 shows the results of the calculations for RL at each chainage as well as the first and second RL differences between the chainages. The arc length is the summation of the chords between each chainage pair.

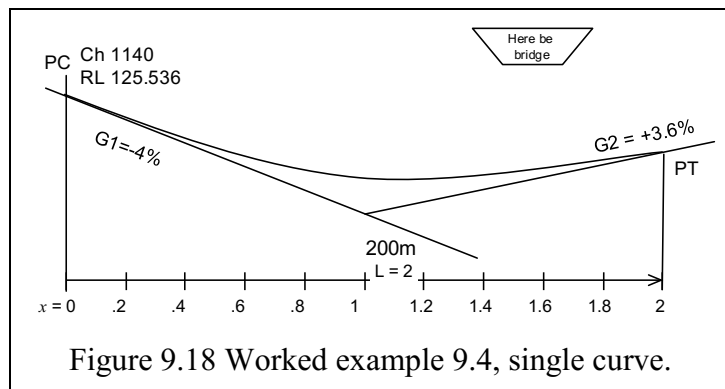

Table 9-1 Worked example 9.4. Table of chainages, RL, first & second differences, chords. Checks.					
Chainage	x	RL	Δ'	Δ''	Chord
1140	0.0	125.536			
			-0.724		20.013
1160	0.2	124.812		0.152	
			-0.572		20.008
1180	0.4	124.240		0.152	
			-0.420		20.004
1200	0.6	123.820		0.152	
			-0.268		20.002
1220	0.8	123.552		0.152	
			-0.116		20.000
1240	1.0	123.436		0.152	
			0.036		20.000
1260	1.2	123.472		0.152	
			+0.188		20.001
1280	1.4	123.660		0.152	
			+0.340		20.003
1300	1.6	124.000		0.152	
			+0.492		20.006
1320	1.8	124.492		0.152	
			+0.644		20.010
1340	2.0	125.136			
Arc Length =					200.047

First difference,
 $\Delta' = RL_{n+1} - RL_n$
 Second difference,

$$\Delta'' = r(dx)^2$$

where:

$$\begin{aligned} dx &= \text{peg interval}/100 \\ &= 20/100 \\ &= 0.2 \end{aligned}$$

i.e.,

$$\begin{aligned} \Delta'' &= r(dx)^2 \\ &= 3.8 \cdot (0.2)^2 \\ &= \mathbf{0.152} \end{aligned}$$

$$\text{Check } \Delta'' = \Delta'_{n+1} - \Delta'_n$$

e.g.,

$$\begin{aligned} \Delta'_{1160} - \Delta'_{1140} &= -0.572 - (-0.724) \\ &= 0.152 \end{aligned}$$

The **chord** of each interval (dx) is calculated using the first difference Δ' .

$$\text{Chord}_{(n, n+1)}$$

$$= \sqrt{(100dx)^2 + (\Delta')^2_{(n, n+1)}}$$

e.g.,

$$\text{Chord}_{(1140, 1160)}$$

$$\begin{aligned} &= \sqrt{(100 \cdot 0.2)^2 + (-0.724)^2} \\ &= 20.013. \end{aligned}$$

Arc length = $\Sigma(\text{Chords})$

Find the low point:

$$\text{Distance to low point (Equation 9.6): } x = \frac{-G_1}{r} = \frac{-(-4)}{3.8} = 1.053 \text{ (distance} = 100 \cdot x = 105.3)$$

Chainage low point = 1140 + 105.3 = **1245.30**, checks by inspection against pegging sheet.

RL of low point at distance x (Equation 9.7a):

$$RL = \frac{1}{2}G_1x + RL_{PC} = -2 \cdot 1.053 + 125.536 = -2.105 + 125.536$$

RL low point = **123.431**, checks against pegging sheet between Ch1240 & 1260.

9.4.2 Worked Example. Multiple Vertical Curves

Figure 9.19 shows the design of two vertical curves, joined by straight sections, to be pegged at 15m intervals over a length of 105m.

The RL at CH 00 is 10.000

Vertical Curve design:

1. The path rises at a slope of +2% between CH 00 and CH 15.
2. The path increases, through a **sag** curve, to a slope of +5% over a length of 15m.
3. The path continues on a straight slope (5%) to CH 75.
4. The path flattens, via a **crest** curve, to a slope, 0%, between CH 75 and CH105.

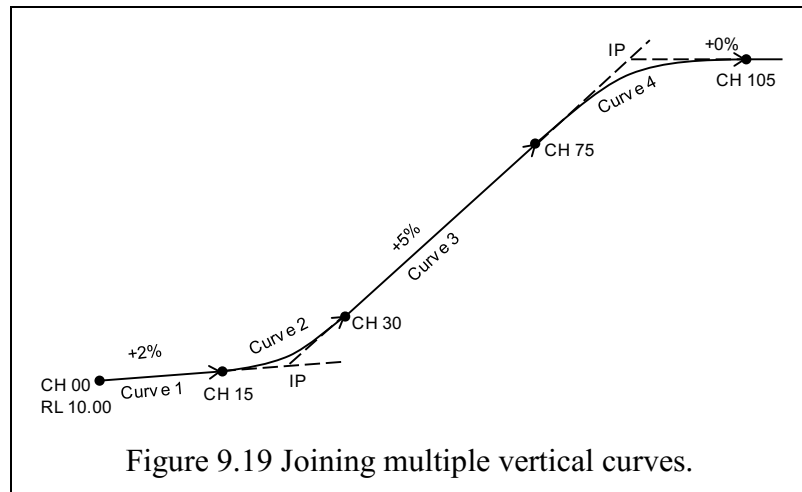

Figure 9.19 Joining multiple vertical curves.

The calculation is broken into four separate parts, the main task being to calculate the RLs at each change of grade. The formula for calculating the RLs over multiple curves replaces the term for the level at the “point of curvature”, RL_{PC} , with the expression, “beginning of vertical curve”, RL_{BVC} .

The RL at the **end** of one vertical curve is the RL at the **beginning** of the next vertical curve.

Only one formula is used: $RL_{CH} = \frac{1}{2}rx^2 + G_1x + RL_{BVC}$.

By definition, the rate of change on a straight slope is, $r = 0$, because $G_1 = G_2$.

1. Straight gradient: CH00 to CH15, $L = 15\text{m} = 0.15$

CH 00, $RL_{BVC} = 10.000$, $G_1 = +2\%$, $G_2 = +2\%$

CH 15, $x = 0.15$ (15m)

$$r = (G_2 - G_1)/L = (2 - 2)/0.15 = 0$$

$RL_{CH15} = \frac{1}{2}rx^2 + G_1x + RL_{CH00} = 0 + 2 \cdot 0.15 + 10 = 10.300$. This is RL_{BVC} for curve 2.

2. Sag curve, CH15 to CH30, $L = 15\text{m} = 0.15$

CH 15, $RL_{BVC} = 10.300$, $G_1 = +2\%$, $G_2 = +5\%$

CH 30, $x = 0.15$ (CH30 – CH15 = 15m)

$$RL_{CH30} = \frac{1}{2}rx^2 + G_1x + RL_{CH15}$$

$$= \frac{1}{2} \cdot 20 \cdot 0.15^2 + 2 \cdot 0.15 + 10.300 = 0.225 + 0.3 + 10.3 = 10.825. \text{ This is } RL_{BVC} \text{ for curve 3.}$$

3. Straight gradient, CH30 to CH75, $L = 45\text{m} = 0.45$

CH 30, $RL_{BVC} = 10.825$, $G_1 = +5\%$, $G_2 = +5\%$,

$$r = (G_2 - G_1)/L = (5 - 5)/0.45 = 0$$

CH 45, $x = 0.15$ (CH45 – CH30 = 15m)

$$RL_{CH45} = \frac{1}{2}rx^2 + G_1x + RL_{CH30} = 0 + 5 \cdot 0.15 + 10.825 = 0.75 + 10.825 = 11.575$$

CH 60, $x = 0.3$ (CH60 – CH30 = 30m)

$$RL_{CH60} = \frac{1}{2}rx^2 + G_1x + RL_{CH30} = 0 + 5 \cdot 0.30 + 10.825 = 1.50 + 10.825 = 12.325$$

CH 75, $x = 0.45$ (CH75 – CH30 = 45m)

$$RL_{CH75} = \frac{1}{2}rx^2 + G_1x + RL_{CH30} = 0 + 5 \cdot 0.45 + 10.825 = 2.25 + 10.825 = 13.075$$

RL_{CH75} is the RL_{BVC} for curve 4.

4. Crest curve, CH75 to CH105, $L = 30\text{m} = 0.30$
 CH 75, $RL_{BVC} = 13.075$, $G_1 = +5\%$, $G_2 = +0\%$,
 $r = (G_2 - G_1)/L = (0 - +5)/0.3 = -16.67$
 CH 90, $x = 0.15$ (CH90 - CH75 = 15m)
 $RL_{CH90} = \frac{1}{2}rx^2 + G_1x + RL_{CH75}$
 $= \frac{1}{2} \cdot -16.67 \cdot 0.15^2 + 5 \cdot 0.15 + 13.075 = -0.188 + 0.75 + 13.075 = 13.638$
 CH 105, $x = 0.30$ (CH105 - CH75 = 30m)
 $RL_{CH105} = \frac{1}{2}rx^2 + G_1x + RL_{CH75}$
 $= \frac{1}{2} \cdot -16.67 \cdot 0.30^2 + 5 \cdot 0.30 + 13.075 = -0.750 + 1.50 + 13.075 = 13.825.$

Table 9-2 shows the results of solving the above problem (Section 9.4.29.4.2), including first and second differences, and chord lengths.

Table 9-2 Vertical curve profile with multiple slopes.					
Chainage	x	RL	Δ'	Δ''	Chord
00	0.0	10.000			
			+0.300		15.003
15	0.15	10.300		0.225	
			+0.525		15.009
30	0.15	10.825		0.225	
			+0.750		15.019
45	0.15	11.575		0.000	
			+0.750		15.019
60	0.3	12.325		0.000	
			+0.750		15.019
75	0.45	13.075		-0.187	
			+0.563		15.010
90	0.15	13.638		-0.376	
			+0.187		15.001
105	0.3	13.825			
Arc Length =					105.080

Note the two sets of formula.
 One for the curve:
 $y = \frac{1}{2}rx^2 + G_1x + RL_{PC}$
 and one for the straight:
 $y = G_1x + RL_{PC}$
 The curve formula can be used for the straight because, as $G_2 = G_1$,
 and $r = (G_2 - G_1)/L$,
 then $r = 0$ and
 thus $\frac{1}{2}rx^2 = 0$.

This may be of help in generalising a spreadsheet application.

9.4.3 Vertical Curves in Rural Road Design

To the surveyor, the common use of the vertical curve is in rural road design and construction.

Austrroads, 2003, Chapter 10, has a comprehensive treatment of vertical alignment to which you are referred.

The vertical profile of a road is a series of grades joined by parabolic curves.

Grades should be as flat as possible taking in to consideration:

- terrain
- longitudinal drainage
- economy.

Steeper grades produce greater variations in vehicle speed between vehicles with varying power to weight ratios.

These variations lead to higher relative speeds between vehicles, increasing risk of rear end accident rates. They also lead to traffic queuing and overtaking requirements, which increase traffic safety problems, especially at higher traffic densities.

There is an additional freight cost due to increased power requirements and lower speeds.

Effects of Grade on Vehicle Type

Table 9-3 Effects of grades on traffic speeds. (Austroads, 2003, Table 10.1, p54).

Grade %	Reduction in Vehicle Speed compared to Flat Grade				Road Type Suitability
	Up hill		Down hill		
	Light vehicle	Heavy vehicle	Light vehicle	Heavy vehicle	
0 - 3	Minimal	Minimal	Minimal	Minimal	For use on all roads
3 - 6	Minimal	Some reduction on high speed roads	Minimal	Minimal	Use on low-moderate speed roads. (Including high traffic volume roads).
6 - 9	Largely unaffected	Significantly slower	Minimal	Minimal for straight alignment. Substantial for winding alignment	For use on roads in mountainous terrain. Usually need to provide auxiliary lanes in high traffic volume.
9 - 12	Slower	Much slower	Slower	Significantly slower for straight alignment. Much slower for winding alignment	Need to provide auxiliary lanes for moderate-high traffic volumes. Consider run-away vehicle facilities for high commercial traffic.
12 - 15	10-15Km/h slower	15% max negotiable	10-15Km/h slower	Extremely slow	Satisfactory on low volume roads. Little/no commercial traffic.
15 - 33	Very slow	Not negotiable	Very slow	Not negotiable	Only in extreme cases & over short lengths. No commercial traffic.

9.4.4 Grades in Rural Road Design

There are two limiting grades in road design.

The first is the minimum grade. It can be zero except in cut where it should be a minimum of 0.5% to provide longitudinal road drainage. An absolute minimum of 0.33% (1 in 300) may be used as long as the table drains maintain a minimum of 0.5% to ensure drainage from the cutting.

Maximum grades affect vehicle performance, and therefore safety. The length of the maximum grade also affects the performance, especially heavy vehicles. A short length of steep grade may be tolerated before performance degradation becomes a problem.

Terrain also affects maximum grades, with the ability to use higher grades over short distances. This may have an effect on construction costs.

Table 9-4 General maximum grades (Austroads, 2003, Table 10.2, p55).

Operating Speed (Kmh ⁻¹)	Terrain		
	Flat	Rolling	Mountainous
60	6 - 8	7 - 9	9 - 10
80	4 - 6	5 - 7	7 - 9
100	3 - 5	4 - 6	6 - 8
120	3 - 5	4 - 6	--
130	3 - 5	4 - 6	--

9.4.5 Length of Vertical Curves in Rural Road Design

The length of a vertical curve should be as great as possible, within economic constraints.

The minimum length of vertical curves is governed by:

1. Sight distance:
a requirement in all situations for driver safety.
2. Appearance:
generally required in situations of low embankment and flat terrain.
3. Riding comfort:
A general requirement to limit increased vertical acceleration through a sag curve to 0.05g. Through approaches to flood-ways, low standard roads and intersections the increase in vertical acceleration may rise to 0.1g.

9.4.6 “K” Value in Vertical Curve Design

The minimum vertical curvature allowed in a vertical road profile and can be expressed as a single value, the **K** value, to allow computerised road design.

$K = L/A$ where:

K = length of vertical curve for 1% change of grade (metres)

L = length of vertical curve (metres)

A = algebraic change of grade (%).

Worked Example 9.5

Worked example 9.4 used a sag curve of length $L = 200\text{m}$. From the example:

$$A = 9.6\%$$

$$K = L/A = 200/9.6 = 21$$

From Austroads, 2003, Table 10.5, p59, this K value represents an operating speed of 110Km/h for a 0.05g sag curve, but (Table 10.6, p59) only 70Km/h for “Headlight sight distance”.

9.4.7 Sight Distance in Vertical Curve Design

Austroads, 2003, Chapter 8, has a comprehensive treatment of sight distances to which you are referred.

Sight distance is the distance necessary for a driver to see, react to and avoid an object on a road. A number of parameters are incorporated in various scenarios to calculate sight distance.

The 3 main parameters are:

Object height: intersection line, 0.0m; object, 0.2m; tail lights, 0.6m

Driver eye height: car, 1.05m; truck, 2.4m

Reaction time: normal 2.5 seconds; alert, 2.0 seconds.

Various types of sight distances can be determined:

1. Stopping sight distance (**SSD**). The distance necessary for an alert driver, travelling on a wet pavement at design speed, to perceive, react and brake to a stop before reaching a hazard on the road ahead.
2. Overtaking sight distance (**OSD**). The distance necessary for a driver to overtake safely a slower vehicle without interfering with the speed of an oncoming vehicle.
3. Manoeuvring sight distance. The distance needed for an alert driver to perceive, react, brake and manoeuvre to avoid an object. It is generally about 6% less than the SSD.
4. Headlight sight distance. The distance that can safely be assumed for the visibility of an object on a bituminous road. This distance is between 120m and 150m. This distance corresponds to a SSD speed range between 80Km/h and 90Km/hr, or a manoeuvring sight distance speed of 100Km/h.

Active visibility objects such as retro-reflective targets (reflectors), car headlights, tail

lights and large or light coloured objects may allow SSD at design speed at night.

Increase in light output has little effect on visibility. A fivefold output increase will only allow a 15Km/h increase in speed. A tenfold increase in light output will allow a reduction of only 50% in object size.

Beam intensity is limited by the requirements of driving visibility and glare to oncoming vehicles.

5. Horizontal curve perception distance. This is the distance needed for a driver to perceive and react to the presence of a horizontal curve that may require speed adjustment. A driver needs to see a sufficient amount of the curve to judge its curvature. The minimums are:

5 degrees of curve, (radius x 5° in radians = $R \times 0.09$, 9% radius.)

about 80m of curve length

the whole curve.

Horizontal curves “hidden” over a crest curve can cause particular perception problems.

These various sight distances produce a recommended range of “K” values that are needed to be incorporated into the design of the vertical profile curve. The designer’s task is to ensure that the design exceeds the minimum values for the design operating speed in various profile configurations.

The surveyor’s task is to apply the design to the parabolic curve formula to calculate the RLs of the vertical stations.

9.4.8 The Arc Length of the Vertical Curve

The task may be to find the **length** of the parabola joining two designated grades.

This is mostly done by summing the chord lengths between each pegging station, if indeed that level of accuracy is required. In general, the **length** of the vertical curve, L , will suffice.

The derivation of the arc length of any parabola is not examined as the effort needed to perform the calculation provides no advantage over the summation of chord lengths.

Worked example 9.3 produced an answer of 200.0480m at 20m intervals (10 steps). Iterating at a $dx = 1\text{m}$ (200 steps) produced an answer of 200.0485m

9.5 Concluding Remarks

For Engineers who will be working on road design and construction, besides the horizontal road alignment that was presented in Chapter 8, the vertical road alignment will also be part of your task. This is necessitated by the need for driver/passenger comfort as the vehicle passes a crest or sag, safe stoppage distance in case of hazards or objects, safe overtaking distance or headlight sight distance. Vertical road alignments occur where gradient changes and is modelled using a parabolic curve (of quadratic type). Essential is for the students to first determine the constant terms of the parabolic equation then apply it to obtain the reduced levels (RLs) at given chainages along the road. This Chapter presented you with the concepts and worked examples on how this is achieved.

9.6 References for Chapter 9

1. Uren and Price (2010) Surveying for engineers. Fourth edition, Palgrave Macmillan, Chap. 14.
2. Austroads, Rural Road Design - A Guide to the Geometric Design of Rural Roads, Sydney 2003. ISBN 0 85588 655 2. *Supersede by:*
3. Austroads, Guide to Rural Road Design Part 3: Geometric Design, AGRD03-16, 2016.

Chapter 10 Global Navigation Satellite System

10.1 Introductory Remarks

In your career in mining and civil engineering, global navigation satellite system (GNSS) mode of positioning will be a routine task. This is because this satellite system is fast revolutionizing these industries in a manner that its inventors never fathomed. Numerous books that cover the GNSS topics exist (see, e.g., Awange 2012 and the references therein). Their applications to Engineering works have also been treated in books e.g., Uren and Price (2010, Chapter 7) and Irvine and MacLennan (2006, Chapter 9). In this Chapter, we provide the fundamental of GNSS and refer the interested students to these books. In particular, the book by El-Rabbany (2006) is suitable for beginners as it is void of many equations found in other GNSS books while Awange (2012, 2017) offers examples of its application to environment, an area that could interest both mining and civil engineers dealing with environmental impacts of their operations. In Section 10.1, we show how the GNSS is revolutionizing the mining and civil engineering operations. Section 10.3 then presents the students with the basic operations of GNSS with GPS as an example. The errors that that underpin the GNSS operations are discussed in Section 10.4 before concluding the chapter in Section 10.5.

Throughout history, position (location) determination has been one of the fundamental tasks undertaken by humans on a daily basis. Each day, one deals with positioning, be it going to work, the market, sports, church, mosque, temple, school or college, one must start from a known location and move towards another known destination. Often the start and end locations are known since the surrounding physical features form a reference upon which we navigate ourselves. In the absence of these reference features, for instance in the desert or sea, one then requires some tool that can provide knowledge of position. To mountaineers, pilots, sailors, etc., the knowledge of position is of great importance. The traditional way of locating one's position has been the use of maps or compasses to determine directions. In modern times, however, the entry into the game by Global Navigation Satellite Systems (GNSS; Hofmann-Wellenhof 2008) comprising the US's Global Positioning System (GPS), Russia's Global Navigation Satellite System (GLONASS), the European's Galileo, and the proposed Chinese's Compass has revolutionized the art of positioning, see, e.g., Awange (2012) and Awange and Kiema (2013). The use of GNSS satellites can be best illustrated by a case where someone is lost in the middle of the desert or ocean and is seeking to know his or her exact location (see, e.g., Figure 10.1).

In such a case, one requires a GNSS receiver to be able to locate one's own position. Assuming one has access to a hand-held GNSS receiver (e.g., Figure 10.1), a mobile phone or a watch fitted with a GPS receiver, one needs only to press a button and the position will be displayed in terms of geographical longitude, λ and latitude, ϕ . One then needs to locate these values on a given map or press a button to send his/her position as a short message service (sms) on a mobile phone as is the case in search and rescue missions. For mining and engineering tasks, use of GNSS is already revolutionising the way operations are carried out (see, e.g., Section 10.2 and also Uren and Price 2010, Chapter 7).

The increase in civilian use has led to the desire of autonomy by different nations who have in turn embarked on designing and developing their own systems. In this regard, the European nations are developing the Galileo system, the Russians are modernizing their GLONASS system while the Chinese are launching a new Compass system. All of these systems form GNSS with desirable positional capability suitable for mining operations and civil engineering tasks. These GNSS desirable capabilities are:

- ✓ **Global:** This enables their use anywhere on earth.
- ✓ **All weather:** This feature makes GNSS useful during cloudy and rainy periods.
- ✓ **Able to provide 24-hour coverage:** This enables both day and night observation and can thus enable, e.g., rescue mission in mine operations to be undertaken at any time.
- ✓ **Cheaper:** Compared to other terrestrial surveying observation techniques such as levelling and traversing discussed in Chapters 2 and 5 respectively, GNSS are economical due to the fact that as an operation, few operators are needed to operate the receivers and process data. Less time is therefore required to undertake a GNSS survey to obtain a solution since it combines both procedures (levelling and traversing) of into a single operation to obtain three-dimensional position.
- ✓ Able to use a global common reference frame (e.g., WGS 84 Coordinate System discussed in Awange 2012).

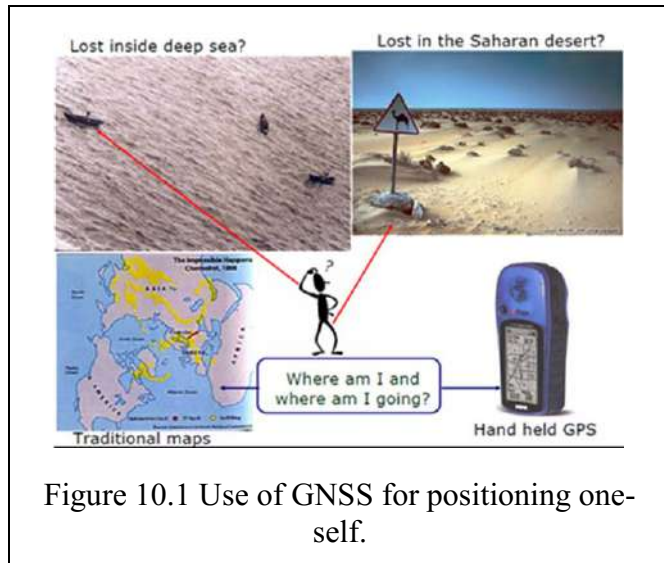

Figure 10.1 Use of GNSS for positioning oneself.

10.2 GNSS, A Revolution to Mine and Civil Engineering Industries

10.2.1 Measuring principle and GNSS Family

Position is calculated by accurately measuring the distance of a receiver from the satellite by determining the delay in the radio signal transmitted by the satellite. This delay is measured by matching and comparing the received signals by an equivalent receiver generated signal. More precise measurements use phase instead of timing measurements. The signals, however, are subject to various sources of errors, which are discussed in Section 10.4. For detailed discussion on the measuring principle, we refer to Awange (2012, Section 3.3).

The Global Positioning System or GPS is the oldest and most widely used GNSS system, and as such will be extensively discussed in this chapter. The development of GPS satellites dates back to 1960's (Hofman-Wellenhof 2001, Leick 2003). By 1973, the US military had embarked on a program that would culminate into the NAVigation System with Timing And Ranging (NAVSTAR) GPS, which became fully operational in 1995. The overall aim was to develop a tool that could be used to locate points on the Earth without using terrestrial targets, some of which could have been based in domains hostile to the US. GPS satellites were therefore primarily designed for the use of the US military operating anywhere in the world, with the aim of providing passive real-time 3D positioning, navigation and velocity data. The civilian applications and time transfer though the predominant use of GPS is, in fact, a secondary role. Not to be left behind, the Russians developed GLONASS that was first launched in 1982 has also been in operation after attaining full operational capability in 1995. Full constellation should consist of 21 satellites in 3 orbits plus 3 spares orbiting at 25,000 km above the Earth surface. Other members of the GNSS family comprise the People's Republic of China's Beidou (also known as Compass) and the European's Galileo under development.

10.2.2 Applications to Mine and Civil Engineering Operations

With the GNSS receivers undergoing significant improvement to enhance their reliability and the quality of signals tracked and the plethora of GNSS satellites discussed in section 10.2.1

above, the world will soon be proliferated with various kinds of receivers that will be able to track several or all GNSS satellites. Indeed, that they will revolutionize mine and civil engineering operations is indisputable. Civil engineering and mining works will benefit enormously from these enhanced and improved GNSS satellites. First, the possibilities of combining some of the main GNSS satellite systems could impact positively on engineering and mining accuracies by meeting demands of various users, e.g., for open pit mining where the haul tracks and machines employ GPS navigation system. Furthermore, safety and rescue missions in mining will benefit from improved positioning accuracy. Evidently, mining companies are increasingly demanding their employees to acquaint themselves with the use of hand-held GNSS receiver (e.g., Figure 10.1) for rescue purposes besides its use in prospecting and exploration. Such tasks stand to benefit from the expanded and improved GNSS system. For civil engineering works, the capability to achieve cm-mm level positioning accuracies in real time will significantly reduce operational costs since the levelling tasks (Chapter 2) and traversing task (Chapter 5) are now capable of being undertaken using GNSS receiver. This will also benefit post construction monitoring of the structures for deformation. While standalone (single) receivers such as that in Figure 10.1 have been known to have 3-15 m accuracies, the expanded and improved GNSS system is already pushing this accuracy to sub-meter level. This is expected to benefit reconnaissance works where stations will be identified to within a radius of less than 3m.

10.3 GPS Design and Operation

In general, GPS is comprised of *space*, *control* and *user segments*, which are described in the following subsections.

10.3.1 Space Segment

This segment was designed to be made up of 24 satellites plus 4 spares orbiting in a near circular orbit at a height of about 20,200 km above the Earth's surface. In June 2011, the orbits were adjusted to supply a 27-slot constellation³ ("Expandable 24") for improved baseline coverage. As of September 2016, there were 31 operational GPS satellites in space⁴. Each satellite takes about 11 hours 58 minutes 2 seconds to orbit around the Earth (i.e., two sidereal orbits the Earth per day, Agnew and Larson 2007). The expandable 24 constellation consists of 6 orbital planes inclined at 55° from the equator, each orbit plane containing 4 + 1 satellites

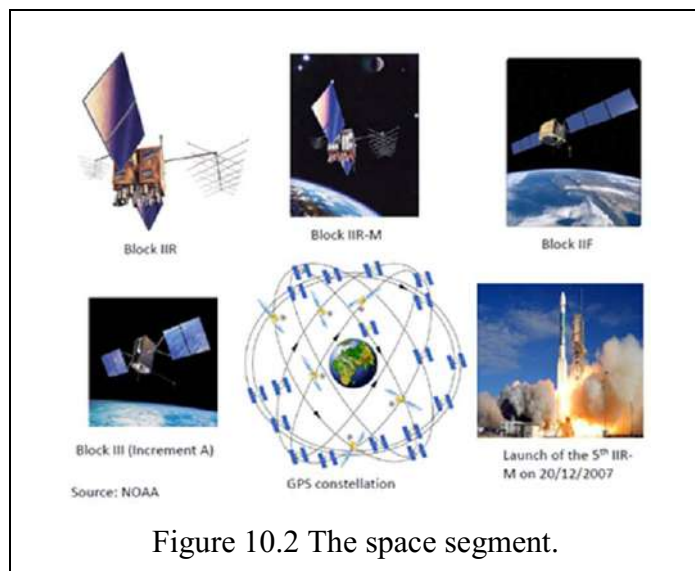

Figure 10.2 The space segment.

(Fig. 10.2). With this setup, and an elevation of above 15° , about 4 to 8 satellites can be observed anywhere on the Earth at any time (Hofman-Wellenhof et al. 2001, 2008, Leick 2003). This is important to obtain 3D positioning in real-time. The satellites themselves are made up

³ <http://www.gps.gov/systems/gps/space/>

⁴ <http://adn.agi.com/SatelliteOutageCalendar/SOFCalendar.aspx>

<http://www.gps.gov/systems/gps/space/>

of solar panels, internal components (atomic clock and radio transmitters) and external components such as antenna. The orientation of the satellite in space is such that the solar panels face the sun to receive energy to power the satellite while the antennas face the Earth to transmit and receive radio signals.

10.3.2 Control Segment

The GPS control segment consists of *master*, *monitor* and *ground* stations. The master control station is located at Colorado Springs (Schriever Air Force Base, Colorado) with a backup station at Vandenberg, California. The ground stations are made up of four antennae located at *Cape Canaveral, Florida*, *Ascension Island* in the Atlantic Ocean, *Diego Garcia* in the Indian Ocean, and *Kwajalein Island* in the Pacific Ocean. By September 2016, nine monitoring stations of the NGA (National Geospatial-Intelligence Agency), six USAF monitoring stations and seven (AFSCN) remote tracking stations are part of the network, enabling every satellite to be seen by at least two monitoring stations and thus improve the accuracy of the computed satellite orbital parameters known as *ephemeris* (see Fig. 10.3)⁵.

These stations monitor the orbital parameters and send the information to the master control station at Colorado Springs. The information obtained from these monitoring stations tracking the satellites are in-turn used to control the satellites and predict their orbits. This is done through the processing and analysis of the information by the master station, which computes the satellite ephemeris and clock parameters and transmits them to the satellites via the monitoring stations. The satellite ephemeris consists of satellite positions and velocities predicted at given times.

There are eleven command and control antennas distributed across the world that augment the control system by monitoring and tracking the satellites in space and transmitting correction information to individual satellites through ground antennas. These stations form the part of the International GNSS Service (IGS) network of over 400 monitoring sites covering all GNSS transmissions. The ground control network is therefore responsible for tracking and maintaining the satellite constellation by monitoring satellite's health and signal integrity and maintaining the satellite orbital configuration.

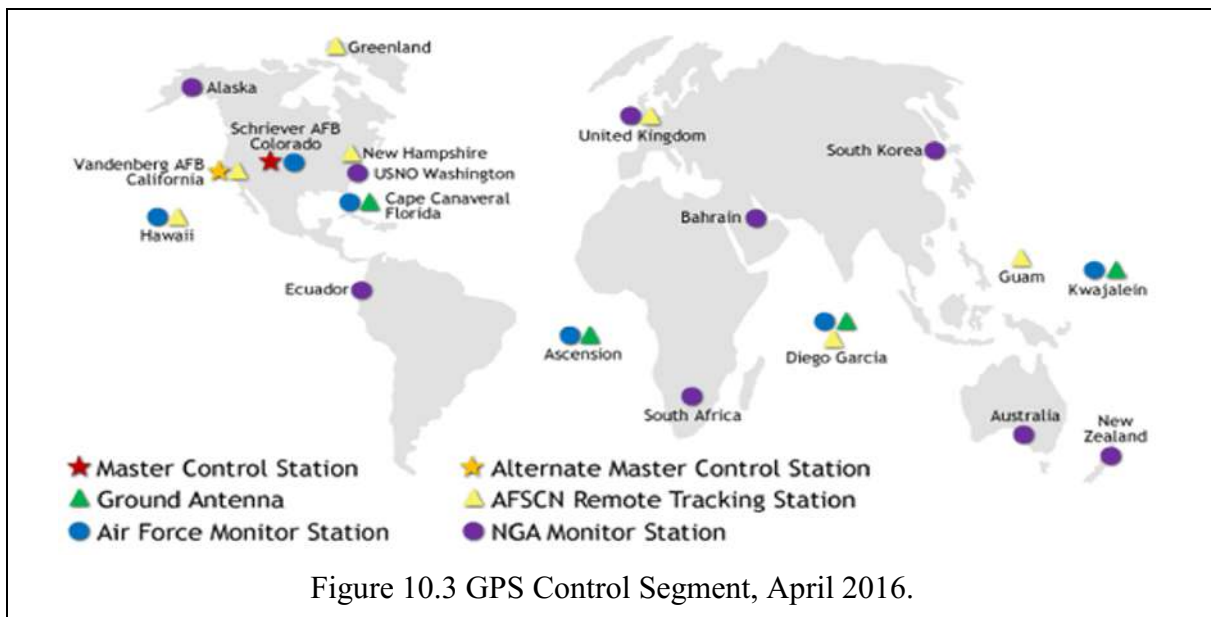

⁵ www.gps.gov/multimedia/images/GPS-control-segment-map.pdf

10.3.3 User Segment

The user segment consists of receivers (most of which consist of 12 channels), which are either hand-held (also available in wrist watches, mobile phones, etc.) or mountable receivers e.g., in vehicles, or permanently positioned. The availability of 12 channels enable receivers to track and process data from 12 satellites in parallel, thus improving on positioning accuracy. These receivers are employed by a wide range of users to meet their daily needs. So wide and varied are the uses of GPS that Awange and Grafarend (2005) termed it the Global Problem Solver (GPS). For military purposes, it is useful in guiding fighter planes, bombers and missiles, as well as naval and ground units.

Civilian use covers a wide range of applications, such as mining, where it is used to guide heavy machinery, or locating positions to agriculture in what has become known as "*precision farming*". Using GPS and GIS, farmers can integrate location, amount of fertilizer and yield expected and analyse the three for optimum output. Modern car tracking companies use GPS to locate stolen vehicles or trucks that have veered away from predestined routes, while in the aviation sector, GPS can be used in both aircrafts and airports to guide landings and take offs. GPS is also widely used in sports such as mountaineering. The list of uses is therefore only limited to our imaginations (see the applications to civil and mine engineering operations in Section 10.2.2).

10.4 Errors in GPS Measurements

Just like any other measurement, the accuracy derived from GPS measurements are subject to errors that degrade the quality of the derived parameters, including those of interest to civil and mine operations. This section considers some of the most significant errors that undermine GPS observations and discusses how these errors could be minimized and/or avoided.

10.4.1 Ephemeris Errors

As the satellites move along their orbits, they are influenced by external forces such as solar and lunar (moon) gravitational attraction, as well as periodic solar flares (Irvine 2006, p.180).

For shorter baselines (i.e., distances less than 30 km between two receivers on Earth), orbital errors tend to cancel through differencing techniques (see Awange 2012). Over long baselines however, e.g., over 1000 km, orbital errors no longer cancel owing to different receivers sensing different components of the error due to significant changes in the vector directions.

Using the data from the monitoring stations, the master control station predicts satellite positions (broadcast ephemeris), which are transmitted to the user as part of the navigation message together with the data signals during positioning. The accuracy of the broadcast ephemeris has improved tremendously, i.e., from 20-80 m in 1987 to 2 m currently, see e.g., El-Rabbany (2006, p.16). El-Rabbany (2006, p.16) attributes this improvement to superior operational software and improved orbital modelling. *Broadcast ephemeris* are useful for real-time positioning (i.e., if the GPS receiver is expected to deliver results while collecting measurements in the field). *Precise ephemeris* on the other hand are useful for post processing tasks which are required later. In such cases, the post-processed positions of the satellites by other global tracking stations are available 17 hours to 2 weeks later with accuracies of meters.

For civil and mine operation tasks, this error should be eliminated when determining the controls (vertical and horizontal discussed in Chapters 2 and 5 respectively). For other tasks, such as machine guidance in mining and general road survey in civil engineering, the error might be insignificant and use of correct positioning procedures that minimize it should suffice.

10.4.2 Clock Errors

Satellite clocks are precise atomic clocks (i.e., rubidium and caesium time standards). In contrast, the receivers cannot include atomic clocks since the cost would be too high for users to afford and for safety concerns. Clocks within the receivers are thus less precise and as such subject to errors. This is not to say that the satellite clocks are error free, but that the magnitude of the receiver errors are much higher.

The satellite and receiver clocks also must be synchronized to measure the time taken by the signal to travel from the satellites to the receiver. Since the synchronization is normally not perfect, errors are likely to occur. This error is also known as time offset, i.e., the difference between the time as recorded by the satellite and that recorded by the receiver (see, e.g., US Army Corps of Engineers 2007).

Satellite clock errors are small in magnitude and easily corrected because the ground control stations closely monitor the time drift and can determine second order polynomials which accurately model the time drift (US Army Corps of Engineers 2007). These second order polynomials are included in the broadcast message. The receiver clock error is determined as a nuisance unknown along with the required coordinate parameters in the observation equation and this explains the need of the fourth satellite.

10.4.3 Atmospheric Errors

The atmosphere is the medium above the Earth by which the GPS signal passes before it reaches the receiver. *Charged particles* in the ionosphere (50-1000 km) and *water vapour* in the troposphere (1-8 km) affect the speed of the GPS signals, leading to an optical path length between the satellite and the receiver and a delay in the corresponding time the GPS signal takes to reach the receiver, see e.g., Belvis (1992). One of the key tasks of geodetic GPS processing software therefore is to “correct” the ranges between the satellite and the receiver to remove the effects of the Earth's atmosphere, thereby reducing all optical path lengths to straight-line path lengths (Belvis et al., 1992).

The *ionosphere* is made of *negatively charged electrons*, *positively charged atoms* and *molecules* called ions. The charged particles are a result of free electrons that occur high in the atmosphere and are caused by solar activity and geomagnetic storms. The number of free electrons in the column of a unit area along which the signal travels between the sending satellite and the receiver make up what is known in GPS literatures as the Total Electron Content (TEC). Free electrons in the ionosphere delay the GPS code measurements, thus making them too long on the one-hand while advancing the GPS phase measurements, making them too short on the other hand, thus resulting in incorrect ranges (i.e., error in the measured ranges) (Hofman-Wellenhof et al., (2001, pp. 99-108; Leick 2003 p. 191).

The size of the delay or advance (which can amount to tens of meters) depends on the TEC and carrier frequency, i.e., the ionosphere is a dispersive medium (Leick 2003 p. 191). The error effect of the ionospheric refraction on the GPS range value depend on sunspot activity, time of the day, satellite geometry, geographical location and the season. Ionospheric delay can vary from 40-60 m during the day to 6-12 m at night (US Army Corps of Engineers 2007). GPS operations conducted during periods of high sunspot activity or with satellites near the horizon produce range results with the highest errors, whereas GPS observations conducted during low sunspot activity, during the night, or with satellites near the zenith produce range results with the smallest ionospheric errors. Ionospheric effects are prominent over longer baselines (> 30-50 km) although high ionospheric activities can affect shorter distances. Ionospheric errors can be significantly reduced through:

- ✓ Use of dual frequency. Since signal speed through the ionosphere is dependent on

frequency (dispersive medium), ionospheric effects which cause a delay of about 2-80 m can be modelled using frequency combination. They are removed mostly by comparing the signal delays of the L1 and L2 frequencies and exploiting the known dispersion relations for the atmosphere (Brunner and Gu 1991).

The disadvantage with using dual frequencies is the increased noise and as such, this approach is useful mainly for longer baselines. For very short baselines (< 5 km), where the atmosphere is assumed uniform, the ionosphere error is minimized once differencing techniques are used (see, e.g., Awange 2012).

- ✓ *Modelling.* GPS navigation messages contain ionospheric correction parameters that are used in correction models during data processing. Several ionospheric correction models, such as the Klobuchar model, are available in commercial software and can be used to reduce ionospheric error. However, this only gives an approximate value that usually does not remove more than 50% of the error. Moreover, modelling is generally inefficient in handling short-term variations in the ionospheric error.

The second medium, the *troposphere*, also known as the neutral atmosphere, consists of 75% of the total molecular mass of the atmosphere, as well as all the water vapour and aerosols. The troposphere is a non-dispersive medium, i.e., the refraction is independent of the frequency of the signal passing through it. Tropospheric errors vary significantly with *latitude* and *height* and are dependent on *climatic zone*. The neutral atmosphere is therefore a mixture of *dry gases* and *water vapour*. Water vapour is unique in this mixture because it is the only constituent that possesses a dipole moment contribution to its refractivity, thus leading to separate treatment between the dipole and non-dipole contribution to refractivity by the water vapour and other constituents in the atmosphere (Belvis et al., 1992).

The tropospheric errors thus comprise two parts: the *hydrostatic part*, commonly referred to in various GPS text as “dry part”, and the dipole component known as the “*wet part*”. According to Belvis et al., (1992) both hydrostatic and wet delays are smallest for paths oriented along the zenith direction and increase approximately inversely with the sine of the elevation angle, i.e., either delay will tend to increase by about a factor of 4 from zenith to an elevation of about 15°.

The *hydrostatic part* contributes 90% of the tropospheric error. It is easily modelled out to a few millimetres or better given surface pressure. The remaining 10% occurs from the wet part, resulting from the *water vapour*, which depends on the refractivity of the air through which the signal is travelling. The refractivity of air depends on (1) the density of *air molecules* (dry component) and (2) the *density of the water vapour* (wet component). Above 50 km altitude, the density of molecules is very low and hence its effect is small. Although the wet delay is always much smaller than the hydrostatic delay, it is usually by far more variable and more difficult to remove (Belvis et al., 1992).

The tropospheric delay therefore depends on *temperature*, *pressure* and *humidity* and affects signals from satellites at lower elevations more than those at higher elevation. For example, El-Rabbany and Belvis (1992) indicates that tropospheric delay results in pseudorange errors of about 2.3 m for satellites at the zenith (i.e., satellites directly overhead), 9.3 m at 15° elevation and 20-28 m for 5° elevation. Therefore, the lower the elevation angle of the incoming GPS signal, the greater the tropospheric effect because the signal travels a longer path through the troposphere.

Tropospheric delay can be problematic, especially when stations are widely distributed at different altitudes. For example, cold (dense) air can accumulate in mountain basins on clear calm nights whilst mountain tops may be considerably warmer. Tropospheric delay can also exhibit short-term variations, e.g., due to the passing of *weather fronts*. The *hydrostatic part*

can be modelled by employing surface meteorological data or by acquiring them from external sources such as the European Centre for Medium Weather Forecast (ECMWF) and the National Center for Environmental Prediction (NCEP).

Whereas the hydrostatic delay can be modelled from the surface meteorological data, the wet component cannot be accurately determined in the same manner, but is instead measured from water vapour radiometers (WVR) (Elgered et al., 1991; Resch 1994; Ware et al., 1986) or by directly estimating the time varying *zenith wet delay* (ZWD) as unknowns from the GPS observations (Herring et al., 1990; Tralli et al., 1988). These estimation techniques usually assume azimuthal symmetry of the atmosphere, and they exploit the form of the elevation dependence of the delay (i.e., the mapping function) and the fact that the delay changes little over short periods of time (Belvis et al., 1992). These analyses typically constrain the variations in the *zenith wet delay* to between 1 and 20 mm per hour, depending on location and time of year, leading to the recovery of ZWD from GPS data with an accuracy between 5 and 20 mm (Belvis et al., 1992).

In most processing software, ZWD is estimated using Integrated Precipitate Water Vapour (IPWV) models. Many models, e.g., Saastamoinen, Hopfield, and Magnet, have been proposed to model tropospheric errors, see e.g., (Hofman-Wellenhof et al. 2001). Some of these models depend on real meteorological data input. However, the best observational principle is to keep the baselines as short as possible.

10.4.4 Multipath

Consider now a satellite signal that is meant to travel straight to the receiver being reflected by a surface, as shown in Figure 10.4. The measured pseudorange reaching the receiver ends up being longer than the actual pseudorange had the signal travelled directly. In urban areas, the presence of buildings contributes greatly to the multipath effect. Multipath errors can be avoided by placing the receiver in a place without reflective or refractive surfaces. The best practice is to place the receiver at least 3 m from reflecting walls and in addition use GPS antennas with ground planes which discard indirect reflected signals (which are of a lower power). A choke ring antenna also provides a means of reducing multipath while other receivers have in-built filtering mechanisms. Good mission planning also helps to reduce the effect of multipath.

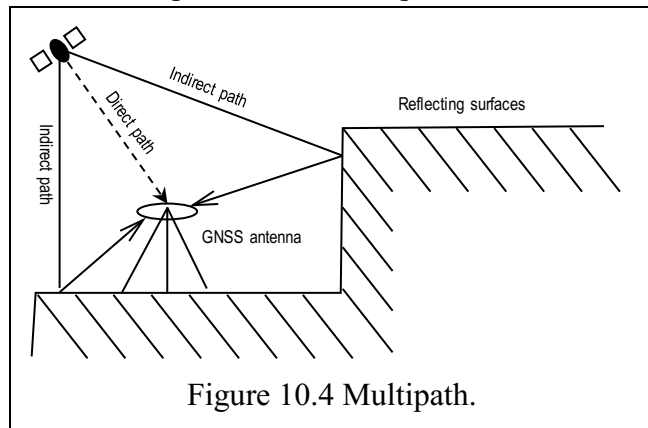

10.4.5 Satellite Constellation “Geometry”

Dilution of precision (DOP) depends on the distribution of the satellites in space (see Figure 10.5). With clear visibility and a large number of satellites, the value of DOP is low, indicating a good geometry. With obstructions and fewer satellites, however, the DOP values become high, indicating poor geometry which may negatively affect positioning accuracy.

Also, used to measure the geometric strength is the Position Dilution of Precision (PDOP) which can be used essentially as an expression of the quality of the satellites geometry. Usually, a PDOP value of less than 6 but greater than 1 is desirable. For a detailed discussion of this topic, we refer the reader to Awange (2012).

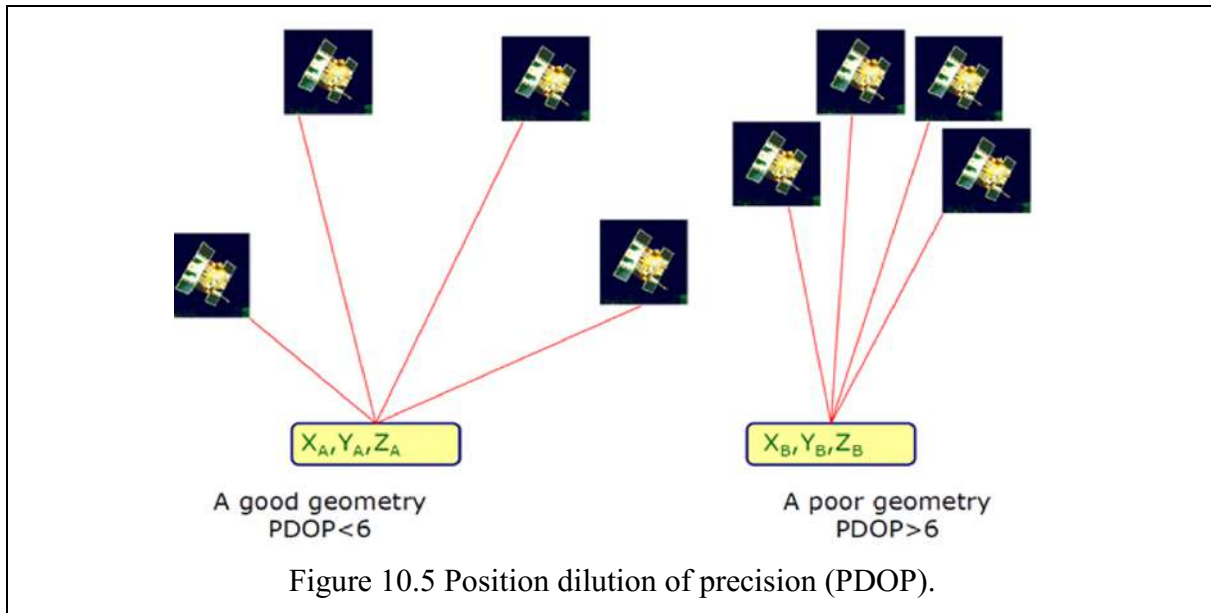

10.4.6 Other Sources of Errors

Other sources of errors which may degrade accuracy include hardware errors due to variations in the antenna phase centres with satellite altitude. This error is greater at elevations below 15° but less between 15° and 60° . In addition, there is receiver noise (e.g., signal processing, clock synchronization, receiver resolution, signal noise, etc.) and cycle slips which results when the receivers lose lock on a satellite due to, for example, signal blockage by buildings. Radio interference, severe ionospheric disturbance, and high receiver dynamics can also cause signal loss El-Rabbany (2006, p.25).

10.5 Concluding Remarks

In summary, this chapter has presented the basics of GPS satellites by looking at areas of applications in civil and mine operations, and the associated errors. In general, the measuring principle and the errors discussed in this chapter are also valid for all the other GNSS systems (GLONASS, Galileo and Compass). They only differ in design, signal structure and coordinate systems.

With the anticipated GNSS systems that will comprise various Global Positioning Satellites, civil and mine operations and management tasks requiring use of satellites will benefit from increased number of satellites. Increased number of satellites will have additional advantages compared to GPS system currently in use. Some of the advantages include additional frequencies, which will enable modelling of ionospheric and atmospheric errors to better resolutions; additional signals that will benefit wider range of tasks; and a wider range of satellites from which the users will be able to choose from. GNSS will offer much improved accuracy, integrity and efficiency performances for all kinds of user communities over the world. Detailed use of GNSS to environmental monitoring and management is presented in Awange (2012).

10.6 Reference to Chapter 10

1. Agnew DC, Larson KM (2007) Finding the repeat times of the GPS constellation. *GPS Solutions* 11: 71-76.
2. Awange JL, Grafarend EW (2005) Solving algebraic computational problems in geodesy and geoinformatics. Springer, Berlin.

3. Awange JL (2012) Environmental monitoring using GNSS. Springer, Heidelberg, New York.
4. Awange JL and Kiema JBK (2013) Environmental Geoinformatics. Springer, Heidelberg, New York.
5. Elgered G, Davis JL, Herring TA, Shapiro II (1991) Geodesy by radio interferometry: Water vapour radiometry for estimation of the wet delay, *J. Geophysics Research*, 96: 6541-6555.
6. El-Rabbany A (2006) Introduction to GPS Global Positioning System, Artech House, 2nd Edition.
7. Irvine W, Maclellan F (2006) Surveying for construction, Fifth Edition, McGraw-Hill, Berkshire.
8. Herring T, Davis JL, Shapiro II (1990) Geodesy by radio interferometry: The application of Kalman filtering to the analysis of very long baseline interferometry data, *J. Geophys. Res.*, 95(12): 561-581.
9. Hofman-Wellenhof B, Lichtenegger H, Collins J (2001) Global Positioning System: Theory and practice, 5th Edition, Springer, Wien.
10. Hofman-Wellenhof B, Lichtenegger H, Wasle E (2008) GNSS Global Navigation Satellite System: GPS, GLONASS; Galileo and more, Springer, Wien.
11. Prasad R, Ruggieri M (2005) Applied satellite navigation using GPS, GALILEO and Augmentation Systems. Artech House, Boston/London.
12. Belvis M, Businger S, Herring TA, Rocken C, Anthes RA, Ware RH (1992) GPS Meteorology: Remote sensing of water vapour using global positioning system. *Journal of Geophysical Research*. 97: 15787-15801.
13. Brunner FK, Gu M (1991) An improved model for the dual frequency ionospheric correction of GPS observations, *Manusc. Geod.*, 16, 205-214.
14. Leick A (2004) GPS satellite surveying, 3rd Edition, John Wiley & Sons, New York.
15. Resch GM (1984) Water vapour radiometry in geodetic applications, in *Geodetic Refraction*, Edt: Brunner, FK, pp. 53-84, Springer-Verlag, New York.
16. Saastamoinen J (1972) Atmospheric correction for the troposphere and stratosphere in radio ranging of satellites, in *The Use of Artificial Satellites for Geodesy*, *Geophys. Monogr. Ser.*, vol. 15, edited by S. W. Henriksen, et al., pp. 247-251, AGU, Washington, D.C.
17. Spilker JJ (1980) GPS signal structure and performance characteristics, in *Global Positioning System*, vol. 1, The Institute of Navigation, Washington, D.C.
18. Tralli DM, Dixon TH, Stephens SA (1988) Effect of wet tropospheric path delays on estimation of geodetic baselines in the Gulf of California using the global positioning system, *J. Geophys. Res.*, 93: 6545-6557.
19. Uren J and Price B (2010) Surveying for Engineers. Palgrave and Macmillan, New York.
20. US Army Corps of Engineers (2007) NAVSTAR Global Positioning System surveying. Engineering and Design Manual, EM 1110-1-1003.
21. Ware R, Rocken C, Hurst KJ (1986) A GPS baseline determination including bias fixing and water vapour radiometer corrections, *J. Geophys. Res.*, 91: 9183-9192.

Chapter 11 Setting Out Of Engineering Structures

11.1 Introductory Remarks

In the preceding chapters, methods and techniques for establishing horizontal controls (i.e., traversing; Chapter 5) and vertical control (i.e., levelling; Chapters 2 and 6) were presented. This Chapter now employs the skills learnt in the previous Chapters to set out the structure physically on the ground. This include, e.g., setting out of buildings for civil engineers or haul roads for open pit mining. Of importance is to know the task required of you, the accuracy for setting it out and checking for errors, the booking of field notes and reading of plans, and last but not least, the communication structure and team working while setting out the structures. This chapter therefore prepares you with the skills necessary to practically set out engineering structures. At the end of the Chapter you should:

- ✓ Understand the basic aims of setting out civil works.
- ✓ Appreciate the key important considerations.
- ✓ Understand the stages in setting out horizontal and vertical positions.
- ✓ Distinguish between various setting out methods.

Definition: Setting out can be defined as the establishment of *marks* and *lines* to define the positions and heights of key points to enable construction to be carried out. The procedure adopted should ensure that a specific design feature, i.e., building, a road, etc., is correctly positioned both in *absolute* and *relative* terms at the construction stage. The two main aims of a setting out survey are to:

- a) Place structures in their correct *relative* and *absolute* position, i.e., the structure must be correct size, in correct plan position and at correct level.
- b) Be carried out rapidly in an efficient manner to minimize construction cost and delay **but be fully checked**.

In Figure 11.1 for example, the tunnel is to be set out in the correct location (horizontally) relative to the trees and correct height to enable the train to pass through.

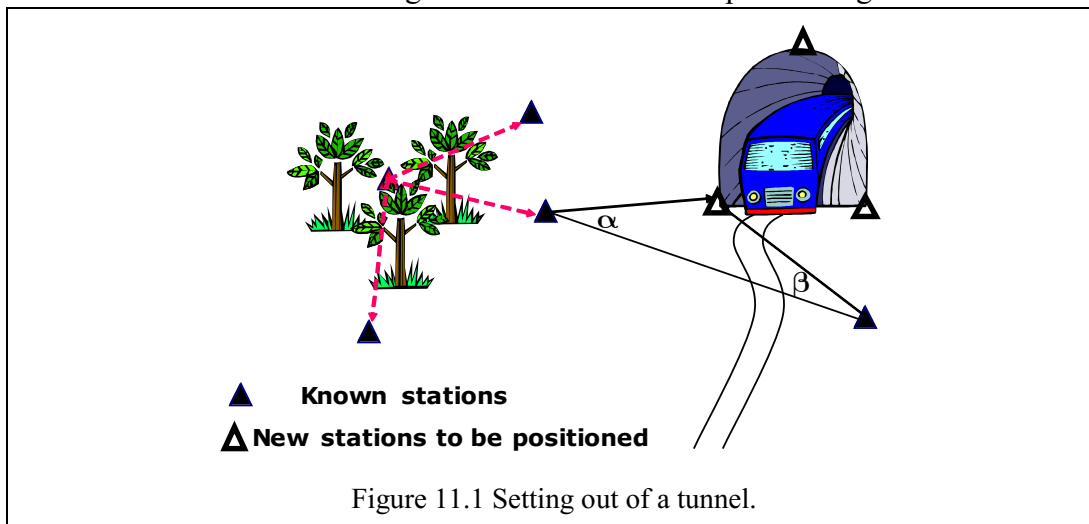

Important Considerations:

- ✓ Recording and filing information – do it once, do it right.
- ✓ Care of instrument – protect, store, clean, check and maintain the instrument. During an engineering project, it is important that the surveyor checks and maintains his/her equipment on a regular basis. The checks and adjustments can be summarized as follows:

- EDM calibration to determine:
 - a) Additive Constant.
 - b) Scale Factor.
 - c) Cyclic Error
- Theodolite calibration checks for:
 - a) Horizontal collimation.
 - b) Vertical collimation.
 - c) Optical plummet.
- Level adjustment for collimation.
- ✓ Maintaining accuracy – right gear for the job.
- ✓ Regular site inspection – what is missing? Check control points and setout pegs for signs of movement on a regular basis.
- ✓ Error detection – independent checks, use other stations. Every survey mark placed must be checked for gross errors.
- ✓ Communication on site – know what has been done and when. The engineer or foreman must be informed what marks have been placed and their relationship to the structure.
 - Diagrams.
 - Plans or sketches
 Communication also ensures good teamwork spirit besides ironing out misunderstanding that may occur during setting out e.g., using the correct plan etc.

11.2 Control Surveying

Control Surveys are performed to provide a network of accurately coordinated points so that the surveyor can carry out:

- a) Site surveys
- b) Setouts of engineering structures
- c) Monitoring of existing structures for deformation.

Due to the different surveying techniques used, control surveying is generally divided into:

- Horizontal Control network with accuracies greater than 1:10000, however should get better than 1:15000 with the right observing techniques. Horizontal controls are established using the traverse method discussed in Chapter 5.
- Vertical control network with accuracies to third order levelling ($12\sqrt{K}\text{m}$ in mm) or better. Chapter 2 provides the method and procedures needed to establish vertical controls.

The exception to this is a GPS survey which provides both horizontal and vertical coordinates – a true 3-dimensional survey. Control surveys invariably include redundant observations which requires the observations to be adjusted using the following methods (See Chapter 5):

1. Bowditch method - The value of the adjustments found by this method are directly proportional to the length of the individual traverse lines.
2. Transit method - Using this method, adjustments are proportional to the values of ΔE and ΔN for the various lines.
3. Equal adjustment - Used for an EDM traverse, where an equal distribution of the misclose is acceptable by adjusting each measured distance by the same order of magnitude.
4. Least squares adjustment - This is the preferred and generally accepted form of adjusting control networks. Its main advantages over the other methods are that:
 - ✓ Takes into account the different quality of angle and distances.
 - ✓ Least squares adjustment will produce a unique solution.

- ✓ Makes the sum of the squares of the corrections (residuals) a minimum.

The main disadvantage with the Least Squares Adjustments is that it cannot be carried out by manual calculation methods. You require:

- Access to a computer.
- Least Squares Program.

11.3 Undertaking an Engineering Construction Project

11.3.1 Personnel involved

In the course of any engineering construction project the involvement of people can be broadly divided into three categories:

1. **Client or Developer** – Provides the finance and impetus for the development.
2. **Project Engineer** – Provides the professional expertise and is responsible for:
 - a) The plans and specifications for the project.
 - b) The letting of contracts for the various stages of construction.
 - c) The general overall management of construction.

The Project Engineer will use the services of a Surveyor to:

- ✓ Carry out any site surveying required for the project design phase.
 - ✓ Provide the initial project control.
 - ✓ Carry out check surveys of structures or survey setouts during the course of construction.
3. **Contractor** – carries out the actual construction of the project. For very large projects it is possible to have a number of different contractors for different stages of the development. The contractor uses the services of a surveyor to:
 - ✓ Provide additional survey control as required.
 - ✓ Carry out the necessary setout surveys for construction.

11.3.2 Recording and Filing of Information

Field notes are an extremely important facet of an engineering survey. They:

- a) Provide documentary evidence of the work carried out and the dimensions used.
- b) If any problems arise during construction, field notes can be used (in a court of law) to prove or verify the correct location of survey marks.
- c) Allow work to be checked at a later date in the office.
- d) Allows other surveyors to carry out work on site using previously set out marks.
- e) Allows the draftsmen to draw up plans showing the location of survey marks and their relationship to the structures being built.

Field notes must be written showing all survey works carried out on a project. They should include:

- a) Date, plan references and plan amendment date used for set-out.
- b) Clear diagram of the survey carried out and all field measurements observed.
- c) Location of all survey marks placed during the course of a survey and checks carried out.
- d) Reference to any electronic data used or stored. The reference should include name of the files used and where they are stored or backed up.
- e) All field notes should be cross referenced in the job file/summary sheet for the project.

11.3.3 Plans

During the course of a project the surveyor will produce or use a number of plans and diagrams from surveys carried out in the field. These can be summarized as follows:

- **Initial survey site plan.** This type of plan will generally show:
 - ✓ All existing structures on the site and directly adjacent to the site.
 - ✓ Levels and site contours.
 - ✓ Location of all services and invert levels to sewerage and drainage lines.
 - ✓ Any other information requested by the project manager.
- **Survey control plans** showing the location off:
 - ✓ Horizontal control and coordinate list
 - ✓ Vertical control and RL's.
- **Engineering design plans.** The project plans are drawn up once the project design has been finalized and incorporates the information provided from the initial site survey. The design plans are used by both the contractor and the surveyor to set out the construction for the engineering project.

NOTE: - Project design is subject to change during the construction phase. It is always the surveyor's responsibility to ensure that he/she is using the most up to date plan available.

- 1 A construction plan will list the dates that any amendments have been made to the design.
 - 2 Before any setout work commences, the amendment dates on the surveyor's plans should always be checked with the site foreman's or site engineer's plans to ensure that he has the most up to date information available.
- **Set out Plans.** As soon as practicably possible the survey must provide a sketch or plan to the site foreman or site engineer showing:
 1. All survey marks placed during the course of a construction survey.
 2. The relationship of the setout marks to the actual structure.
 3. A record of work carried out during the engineering construction.

It must be remembered that one of the most common errors on a construction site is associated with misunderstanding the location of survey setout marks in relation to the structure.

11.3.4 Setting out Methods and Procedures

Accuracy of the setting out: The accuracy of the survey work carried out for a construction project will depend on the project specifications. These specifications will vary from project to project, and is dependent on the precision required for construction. The accuracy of a *control survey* for a construction site is:

- a) To a greater accuracy than that of the construction specifications.
- b) Dependent on the equipment and observation procedures used.

Procedure and Methods: During the life of a project the surveyor will generally set out the *initial horizontal control* network and then add additional control points as required. Initial controls are generally carried out by a control traverse that is either link or closed (see Chapter 5). In what follows, we present the methods for setting out (i) the horizontal controls, and (ii) the engineering structure.

Stages in Setting out: Horizontal control: In general, a preliminary survey will first be carried out. In this regard,

- Check the design – what can be set out and from where?
- Perform a reconnaissance – on site and adjacent to site; are they protected or not protected?
- Survey the stations – are they temporary or permanent?
- Check the Bench Marks – Are there TBM, State BMs, or site BM?
- Collect and study the plans – site surveys, both cadastral and topography:

Coordinate Systems: For large engineering projects a grid system is generally used. This

grid may be based on (i) national coordinate system, e.g., Map Grid of Australia (MGA) coordinates for Australia, which are generally used for projects covering very large areas, (ii) arbitrary grid – usually designed to be parallel to the structure and referred to as a ‘**SITE GRID**’ (Figure 11.2), and (iii) secondary grid – grid established inside a structure. These types of grids are generally set out parallel to the structure itself to facilitate construction (Figure 11.3).

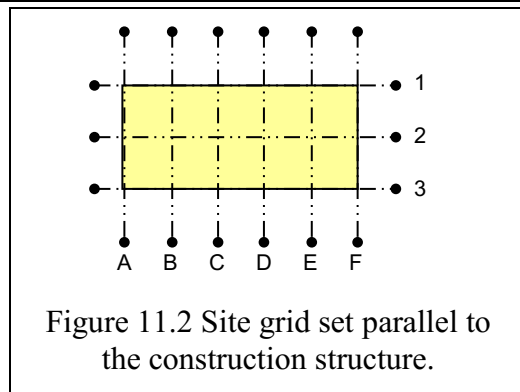

Figure 11.2 Site grid set parallel to the construction structure.

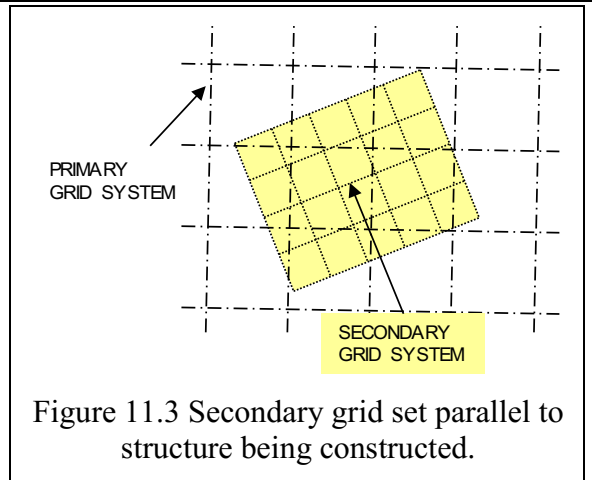

Figure 11.3 Secondary grid set parallel to structure being constructed.

In the case of small buildings or structures, the control is either set out:

- Parallel to a one cadastral boundary - In this case the boundary marks have been used for the baseline for the horizontal control (Figure 11.4).

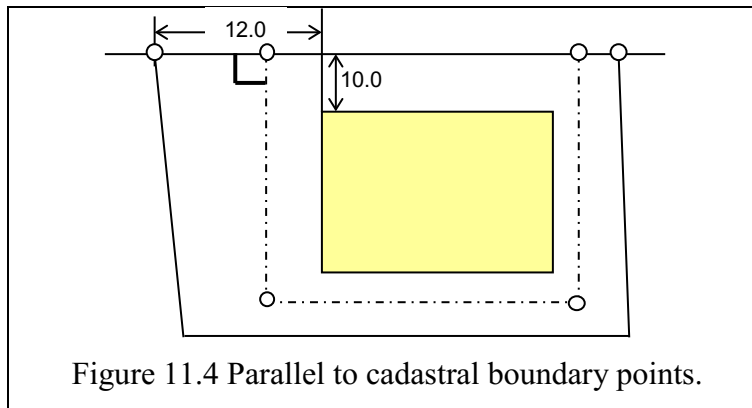

Figure 11.4 Parallel to cadastral boundary points.

- Related to the cadastral boundary (Figure 11.5).

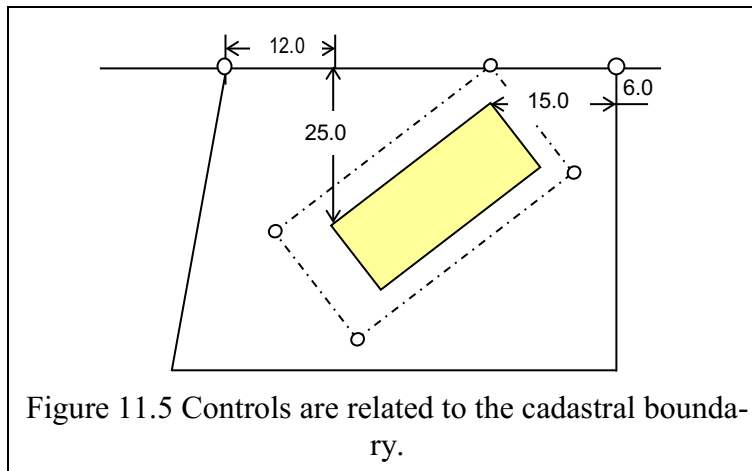
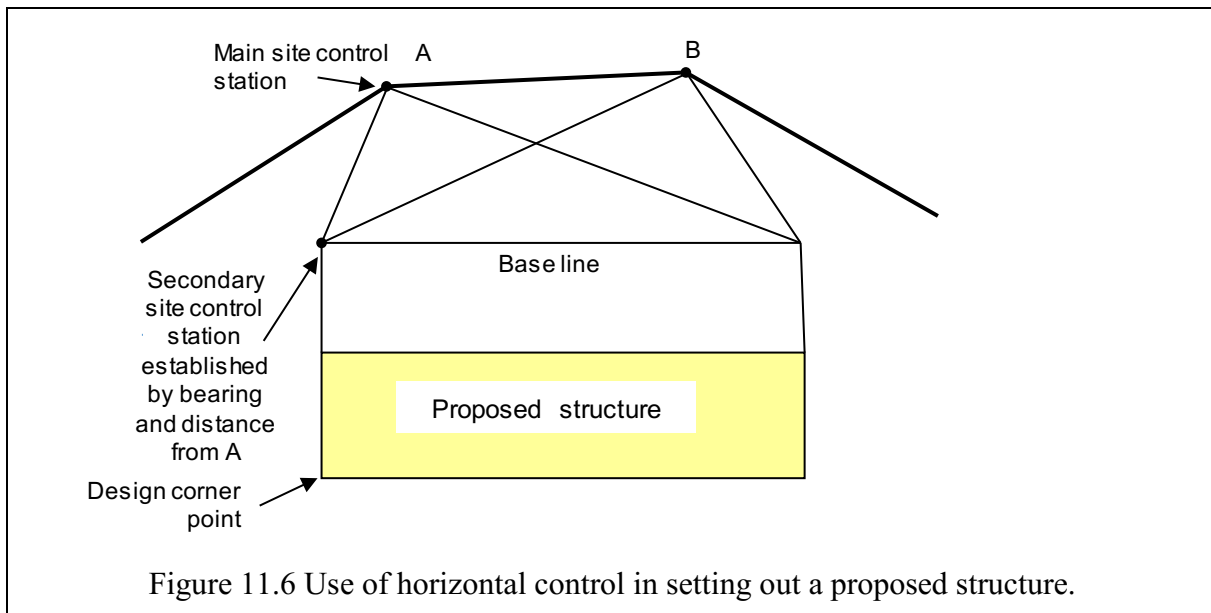

Figure 11.5 Controls are related to the cadastral boundary.

Horizontal controls MUST be brought near the feature to be set. In Fig. 11.1, you will note that the horizontal controls have been brought near the tunnel to be set. In general, the principle of working from whole to part is followed. Normally, the outer (closed traverse) is set by bearing and distances measurements. They are then used to set up site stations that are subsequently used to set up differing grids (Figure 11.6):

- Survey grid: Usually related to mapping in the area.
- Site grid: Usually related to survey grid at several points on site, but distance set to true for site (Figure 11.2).
- Structure grid: can vary between parts of large construction, i.e., in either scale or direction (mathematical transformation).
- Secondary grid: established within structure (Figure 11.3).

Reference marks with known heights are required and accurate methods must be adopted.



Methods for establishing horizontal control. Some of the methods include (Awange and Grafarend 2005; Uren and Price 2010, p 272 onwards)

- Traverse method discussed in Chapter 5. This include linked, closed and braced quadrilateral or triangular network – these types of network are used in situations where high accuracy control is necessary – 2nd order or better (Figure 11.7).

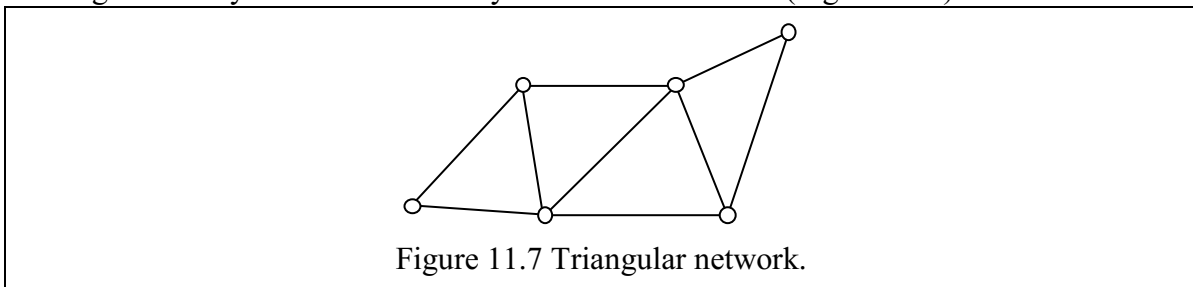

- Intersection is the measurement of distances or angles from two known points to a third point. (Figure 11.8).

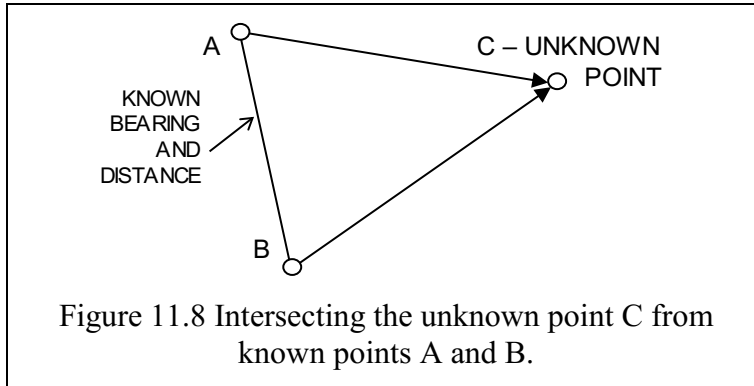

Example: Given the coordinates of control points at an open pit mine site as A (892.387E(m), 907.800N(m)) and B (1194.656E(m), 955.662(m)), with only angles measured from points A and B to the unknown point C as $\alpha=9^{\circ} 47' 47''$ and $\beta=8^{\circ} 42' 58''$, locate station C without occupying it. Two formulæ could be used based on either angles or bearings as follows (Figure 11.9):

Using Angles:

$$E_C = \frac{\{(N_B - N_A) + E_A \cot(\beta) + E_B \cot(\alpha)\}}{\cot(\alpha) + \cot(\beta)}$$

$$N_C = \frac{\{(E_A - E_B) + N_A \cot(\beta) + N_B \cot(\alpha)\}}{\cot(\alpha) + \cot(\beta)}$$

Figure 11.9 Intersection by angles or bearings.

Using either measurement leads to the following position of C:

Angle method: $E_C=1038.434\text{m}$, $N_C=905.764\text{m}$ and

Bearing method: $E_C=1038.436\text{m}$, $N_C=905.764\text{m}$.

- Resection is the measurement of angles or distances from an unknown point (D) to three or more known points (A, B, C) in Figure 11.10.

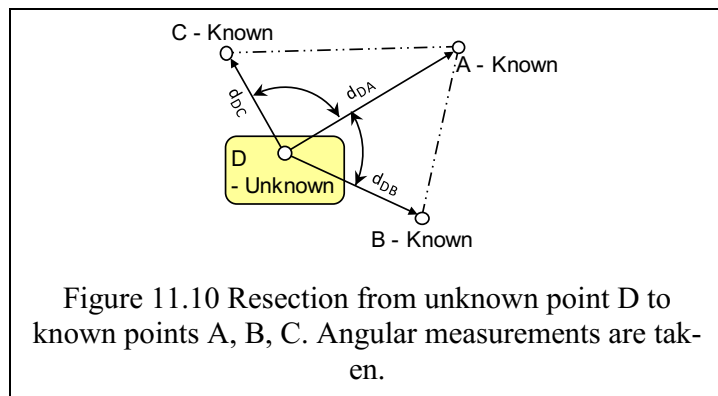

- For inaccessible areas, Photogrammetry method (Figure 11.11) is used (see Awange and Grafarend 2005, p. pp.168-171 for details).

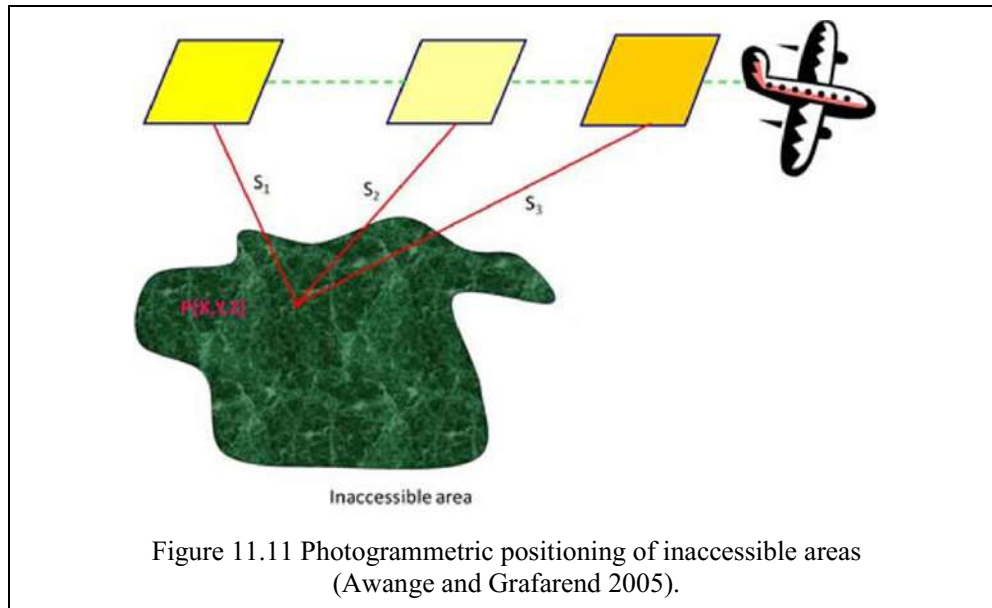

Methods for setting out engineering structure. Set out points for structures can be either carried out by

- ✓ Baseline method - This method involves the setting up of a baseline parallel to the structure. This is especially effective where a horizontal grid system has been established as part of the control (see Figure 11.4). The advantages with this system are (i) dimensions are read directly from the plan, no calculations, (ii) only simple calculations required, and (iii) only use 90° (i.e., perpendicular offsets from the baseline).
- ✓ Radiation from a point (Figure 11.12) - The main advantage of this method is that it is very quick in the field.

Its main disadvantages are (i) it may involve coordinate calculations, (ii) setout must be checked from a different location, and (iii) orientation error difficult to check unless angles/bearings are read to a third control point.

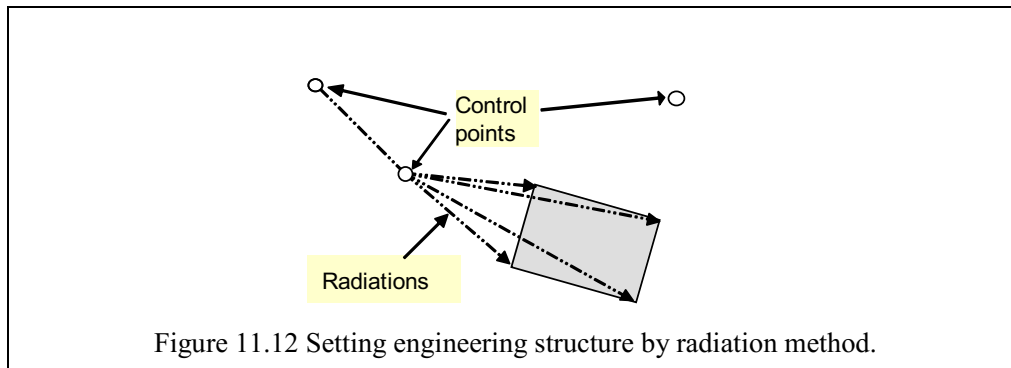

- Radiation from a resected point (see Figure 11.13) - This method is a variation of the radiation point method. Instead of setting up on a known control point. This method involves:
 - ✓ The instrument is set up in any convenient location on the site.
 - ✓ A resection is carried out to the surrounding control points.
 - ✓ The coordinates of the instrument (Free Station) are calculated using either Total Station software or computer (calculator) program.

- ✓ The coordinates for the Construction points to be set out are calculated and used to calculate a bearing and distance from the Instrument station.
- ✓ The last step should involve a check on your work. It should involve:
 - (i) Distance check between each set out point
 - (ii) New resection and radiation to set out points.
- ✓ Main disadvantages using the Resection method are:
 - ❖ May involve coordinate calculations for set out points.
 - ❖ Set out must be checked from a different location.
 - ❖ Resection must be to three or more control points, where both distances and angles are read (need redundancy to ensure gross errors are detected).
 - ❖ Need resection software on Total Station or in calculator.

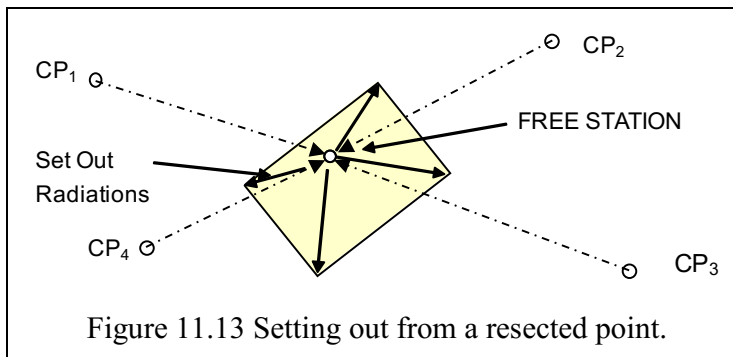

Stages in Setting out: Vertical Control. Transfer heights from state BMs to site. These helps with determining

- ✓ Drainage, roads, and service levels.
- ✓ Setting heights on slab of buildings (Figure 11.14). The staff is placed on the datum point and the height read as 3.173m. Next the height is moved to the slab and the reading 1.74 m read to set the slab's reduced level at 16.5m
- ✓ Control from floor to floor level. This includes vertical plumbing, concrete thickness, layout of pillars and elevators etc.

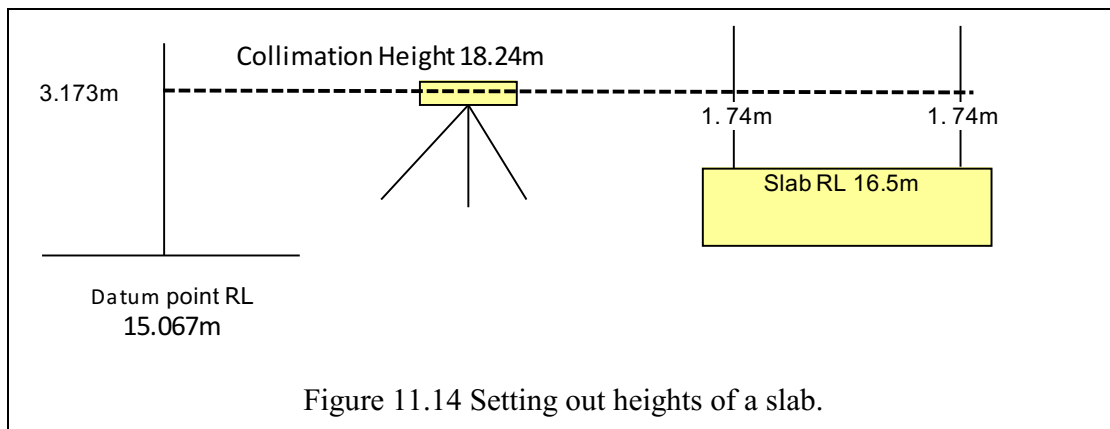

For vertical control, it is important to:

- ✓ Ensure that there are an adequate number of points available on site.
- ✓ Ensure bench marks are solid and well protected.

The accuracies associated with levelling on site can generally be given as:

- For soft surfaces ± 0.010 m.
- For hard surfaces 0.005 m.
- For levels on pegs or structures usually given by the Project specifications.

NOTE: When providing levels on site it is always important to ensure that you use at least two BM's in your levelling traverse. This ensures that:

- ✓ BM has not been disturbed.
- ✓ RL transcription errors are found

Vertical control on a construction site can be provided by:

- 1) Spirit levelling (Chapter 2). This technique is generally used where high accuracy's over relatively small areas are required. The generally accepted accuracy for vertical control on most project sites is third order levelling – $12\sqrt{\text{km}}$ given in mm.
- 2) Trigonometric heighting (see Chapter 6 for details). A theodolite can be used to measure the difference in elevation between two points (Figure 11.15). This method is called trigonometric heighting and for short distances of less than 200 to 300 m, it will give a reasonable accurate answer. It generally tends to be used in situations where:
 - ❖ High accuracy vertical control is not necessary – 4th order or less.
 - ❖ It is difficult or impossible to carry out a spirit levelling survey due to physical obstructions – large water bodies, hills valleys etc.
 - ❖ It is necessary to bring in vertical control over long distances.
 - ❖ This may very well be the case in remote areas of the state.
 - ❖ The existing vertical control in the area is by Trigonometric heighting.

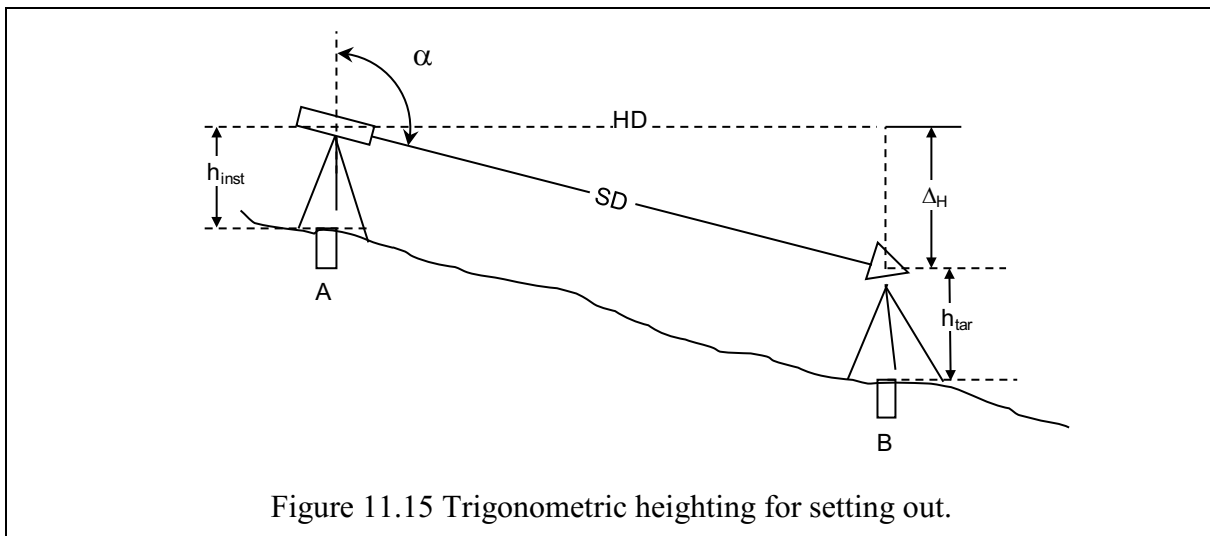

There are several corrections associated with Trigonometric Heighting that must be applied over long distances. Major ones are:

- 1) Curvature of the Earth over long distances must be corrected: Point A and B, in Fig. 11.12, are the same relative level. Approximate formulae for curvature (C) is C (metres) = $0.0784K^2$ – K is in kilometres.

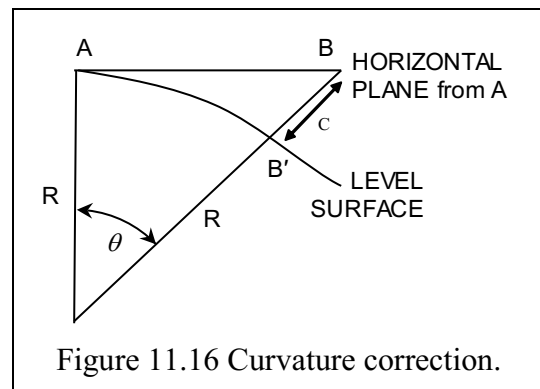

- 2) Vertical refraction (Fig. 11.15): An error occurs due to the bending of a light ray as it passes through changing air densities – refraction. The angular error correction is referred to as the coefficient of refraction (k) and varies significantly over a 24-hour

period. Over long distances, refraction and Earth's curvature, can be eliminated by taking simultaneous trigonometrical heights or near simultaneous trigonometrical heights and averaging the two differences in RL.

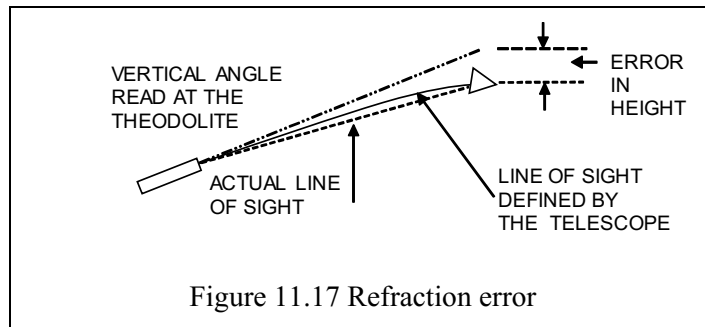

The Accuracy of Trigonometric heighting is a function off:

- ✓ The instrument accuracy – vertical angle
- ✓ The accuracy to which the height of instrument above station has been measured to.
- ✓ The accuracy to which the height of target above station has been measured to.
- ✓ The effects of refraction.

Of the four errors listed above the refraction error tends to be the largest and the least quantifiable.

11.4 Concluding Remarks

Whereas in your professional career as civil and mine engineers you might not be the ones carrying out the survey for setting out the structures, a task normally undertaken by surveyors within the company, knowledge and understanding of what they do is of great importance. This is because the overall responsibility of overseeing the construction could be squarely on you and hence the need to understand the types of controls used, data collected together with their accuracies and how they are used to realize the setting out of the structure. Be an active civil and mine engineer who can regularly visit the site for inspection and remember that a successful setting out is a function of “Good Surveying Practices”. These can be summarised as follows:

- ✓ Keep clear and accurate records (Field notes + electronic information).
- ✓ Adopt logical filing system for all information associated with the job.
- ✓ Look after all survey instruments, calibrated and serviced regularly.
- ✓ Be familiar with the construction site.
- ✓ Check all plans and drawings for dates and latest design amendments.
- ✓ Place all control points in safe locations and protect from accidental damage.
- ✓ Inspect the site regularly. Make sure pegs placed and control points have not been knocked or moved.
- ✓ Plan your setting out schedule to correspond to the construction program.
- ✓ Work to survey specifications for the project.
- ✓ Maintain the required accuracy at all times.
- ✓ Check all field work by an independent method.
- ✓ Communicate results to contractor – notes and plans.

11.5 References to Chapter 11

1. Uren and Price (2010) Surveying for engineers. Fourth edition, Palgrave Macmillan, Chap. 14.
2. Banister and Raymond (Solving problems in Surveying, 1990, Longman Group, UK), Chap. 7.
3. Awange JL, Grafarend EW (2005) Solving algebraic computational problems in geodesy and geoinformatics. Springer, Berlin. Chapters 11 and 12 (<http://www.springer.com/environment/environmental+management/book/978-3-540-88255-8>)

Chapter 12 Coordinate Transformation And Least Squares Solutions

12.1 Introduction

Coordinate transformation plays a significant role in civil engineering and mining operations, for example, where coordinates obtained in the GNSS system discussed in Chapter 10 needs to be transformed into local systems, e.g., local mine grid system. This Chapter offers fundamentals of transforming the coordinates from one system to another and provides the basics of the least squares solutions, the method that is employed for such transformation.

The matter of coordinate transformation from one system to another depends on a number of factors; coordinate system and datum, orientation, area (size), purpose and accuracy requirements. The transformation parameters and methods also depend on the “accuracy” of the initial observations.

Coordinate transformations rely on having a number of points known in both coordinate systems. And they rely on the observational accuracy with which each system has been observed and calculated.

It is important to remember that, for the purposes of this discussion, the transformation is from one set of plane coordinates into another. The transformation of plane coordinates to geographic coordinates, latitude and longitude, depends on the datum, the chosen “figure of the earth” and the projection, the mathematical methods and formulae, of the transformation (see e.g., Awange nad Grafarend 2005, Awange and Palacnz 2016 for more details).

12.2 Definitions

Datum is used to describe, for a particular region or the whole earth, a simple set of parameters that will best locate a point on the surface of the earth. In using a datum, again, the purpose for which it will be utilised must be examined. The position’s place on the earth is also determined by temporal parameters describing the earth’s rotation in space. Location can thus be described, in order of complexity, as:

1. Plane, the “flat earth”, measured in linear units, of infinite radius,
2. Spherical, the “round earth”, of a single radius, and
3. Elliptical, the ellipsoidal or “spheroidal”, earth, of two radii; the major and the minor semi-axes.

Projection is the mathematical set of parameters that are used to basically transform between a point’s position on the earth to a plane. It is the projection that allows us to represent the earth on maps of varying scales and uses. Again, in order of complexity, we have commonly used:

1. Tangent plane, mapping from a single point outwards to all other points
 - Plane, stereographic, orthographic,
2. Cylindrical, wrapping the earth in a cylinder, either around the equator or a meridian (over the poles),
 - Mercator, **Transverse Mercator** (Gauss-Kruger, UTM, MGA94 etc)
3. Conical, placing a cone above a pole so that the cone is tangential the earth on a parallel of latitude,
 - Lamberts Conic Conformal (single parallel, or World Aeronautic Chart 1:1,000,000 with two parallels).

The **spherical** earth. Until the introduction of **geodesy**, the study of the **shape** of the earth, in the 19th century the enlightened opinion of map makers (cartographers) was that the earth was “round”. It was a ball with a spin axis through the poles, the North and South poles, and an equator perpendicular to the polar axis at the maximum radius. The tricky bit being to determine the radius. Position on earth was determined by increasingly accurate observations

of the stars, planets, the Moon and the Sun. Figure 12.1 illustrate an elliptical earth. For the spherical earth

point M moves to O so that $OE = ON = OP = \text{radius}$.

The expressions used to describe a position on the earth are (see Figure 12.2):

Latitude, the angular distance, $A'MP$, from the parallel of the equator, EQ , to the position, P .

A **parallel** of latitude is the small circle perpendicular to the polar axis, NOS ;

Longitude, the angular distance, AOB , between a **reference meridian**, $NGBS$, and the meridian through the point, $NPAS$ (Figure 12.2).

A **meridian** is the great circle perpendicular to the equator through the poles (a great circle).

Height, the **elevation** above (or below) the radius of the earth. Since most of the earth is covered in water the natural height datum is “sea level”, the declared radius of the earth,

- **Sea level** is the long term average of observations of the ocean’s level against the land (recall Chapter 2).

Measurement of position:

Latitude, “the latitude of the place is the elevation of the pole”. The (N or S) pole has a declination of 90° from the equator. By measuring elevation to a celestial body of known declination the latitude can be calculated. A fairly simple exercise.

Longitude is the angular distance between a reference meridian and the point. An exercise in time (tricky that.). Reference meridians include Ferro (from the 2nd century AD the western edge of the Old World), Paris (20°E of Ferro, $2^\circ 20' 20''\text{E}$ Greenwich), Greenwich (Airey transit telescope, 1844) and now the IERS Reference Meridian (IRM) some 102m east of Greenwich.

Height. Sea level, and its corresponding equipotential (equal gravity) surface under the land, is expressed by the Australian Height Datum (AHD09), Earth Gravitational Model (EGM1996). Recall Sections 2.2 and 2.3, discussing the AHD.

Quick and dirty on the spherical earth. Many navigation problems, on land, sea and in the air, can be solved to a satisfactory level of accuracy using simple spherical trigonometry and either the mean radius of the earth at the line midpoint, or the “1 minute of arc of latitude = 1 nautical mile” definition. The nautical mile has been variously defined as: 1) 6080 feet (1853.2m), based on the Clarke (1866) spheroid and 2) 1852m (First International Extraordinary Hydrographic Conference, Monaco (1929). This implies a radius of about 3,437.7nm or 6,366,707m.

A spherical triangle is formed by the intersections of three great circles on the sphere. Solution of the spherical triangle involves the arc length of each side and the angle between them. The sum of the 3 angles is greater than 180° by the “spherical excess”, quite a small number in navigation, and ignored except to calculate area of the triangle.

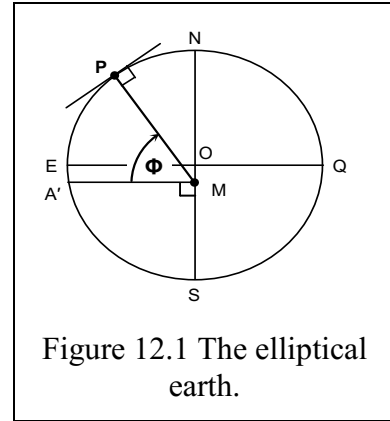

Figure 12.1 The elliptical earth.

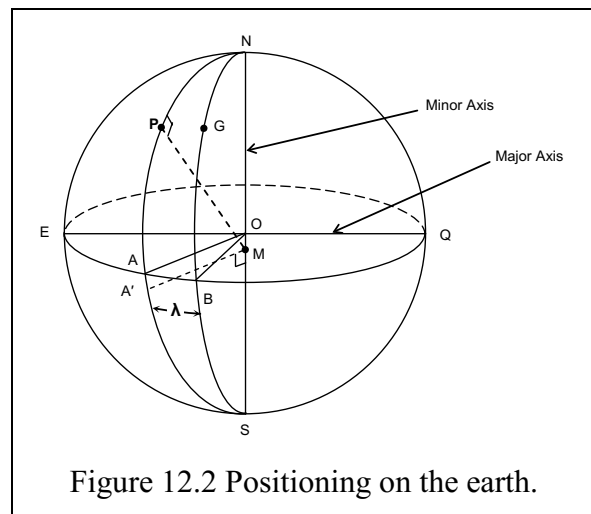

Figure 12.2 Positioning on the earth.

The easiest treatment of spherical trigonometry is found in Mackie, 1978.

The results of calculations, compared with the “true” distance over an ellipsoidal earth, are of sufficient accuracy to allow flight and sail planning, especially considering the vagaries of wind and wave.

Mean and tricky on the ellipsoidal earth. Geodetic computations on the ellipsoid are outside the scope of this document. The conversion between positions on the ellipsoid, and the direct problem of generating a position from an azimuth and ellipsoidal distance are adequately handled by Vincenty’s Inverse formula and Vincenty’s Direct formula. These methods superseded the Robbin’s and Robbin’s Reverse methods employed previously.

The reader is referred to the Geoscience Australia website: (<http://www.ga.gov.au/scientific-topics/positioning-navigation/geodesy/geodetic-techniques/calculation-methods>).

12.3 Transformation methods

The methods explored here are of two types:

1. Block or Datum shifts,
2. Conformal transformations.

12.3.1 Block shift

Transforming between some local coordinate system and a national system from low accuracy transformation parameters.

By this we may mean transforming hand held GPS coordinates into a local grid system to incorporate UTM gathered data in a local map. Or transforming local coordinates to UTM to allow recovery of points by GPS.

A handheld GPS can typically gather at the 3-5m accuracy level. Using its data, even on the most accurate set of coordinates, the resultant transformation cannot be expected to be any better than the basic GPS accuracy.

Datum shifting is a powerful tool in computations and, for teaching purposes, is employed on the realization of the UWA grid, which is based on the Perth Coastal Grid. The same technique is applied to Map Grid of Australia (MGA94) coordinates for computational purposes.

Taking, for example, GNSS coordinates of points known in an example UWA grid and also in the MGA94. It is a simple matter to find the shift in Easting and Northing between them. The UWA grid is translated from the Perth Coastal Grid (PCG94). Figure 12.3.

JO1 UWA grid	MGA94	Shift
E: 1069.120	388270.020	dE = 387200.9
N: 5290.789	6461092.588	dN = 6455801.8
JO2 UWA grid	MGA94	Shift
E: 1188.113	388388.505	dE = 387200.4
N: 5333.960	6461137.047	dN = 6455803.1

The difference in shift values between the two coordinate differences is due, mainly, to the rotation of about 38minutes of arc between the grid bearings.

The mean shift could be represented, at the 1m level, as 387,200E and 6,455,802N. This is well within the accuracy of the handheld GPS. At a scale of 1:1,000 these values can be plotted to the mm level.

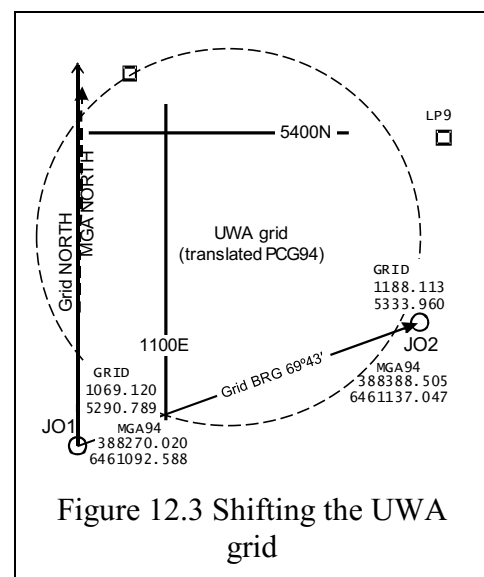

Figure 12.3 Shifting the UWA grid

By way of example, a GPS UTM reading of E388285, N6461225 could be transformed to UWA grid as:

$$388285 - 387200 = E1085,$$

$$6461225 - 6455802 = N5423, \text{ on the north-western edge of the oval.}$$

Conversely, a scaled point, say LP9, at UWA E1196, N5397 becomes, in UTM coordinates:

$$1196 + 387200 = E388396$$

$$5397 + 6455802 = N6461199$$

12.3.2 Conformal transformation

A conformal transformation between two systems maintains angles between the systems, and so the shape of a small area.

Transforming between two coordinate systems uses four (4) parameters; datum shift in E and N, scale change equal in E and N and angle rotation between the systems.

There are a number of different coordinate systems that can be used for an exploration or mining project. Generally an existing mine site will be based on a Local Mine Grid (Flat Earth system), but should be connected into the Geodetic Datum of Australian (GDA). It is quite probable that an initial exploration program will be based on MGA94 coordinates. In both situations it then becomes necessary to be able to transform a set of coordinates from one system to another.

Generally a Local Mine Grid is based on a selected datum point located in a safe area on site and is given an arbitrary set of coordinates. In addition, the coordinate system will be orientated by selecting a second datum point in a particular direction. Common Local Mine Grid coordinate grid orientations can be based on; the direction of the ore body strike, Magnetic North, True North (Figure 12.4) or any other direction that seemed appropriate at the time.

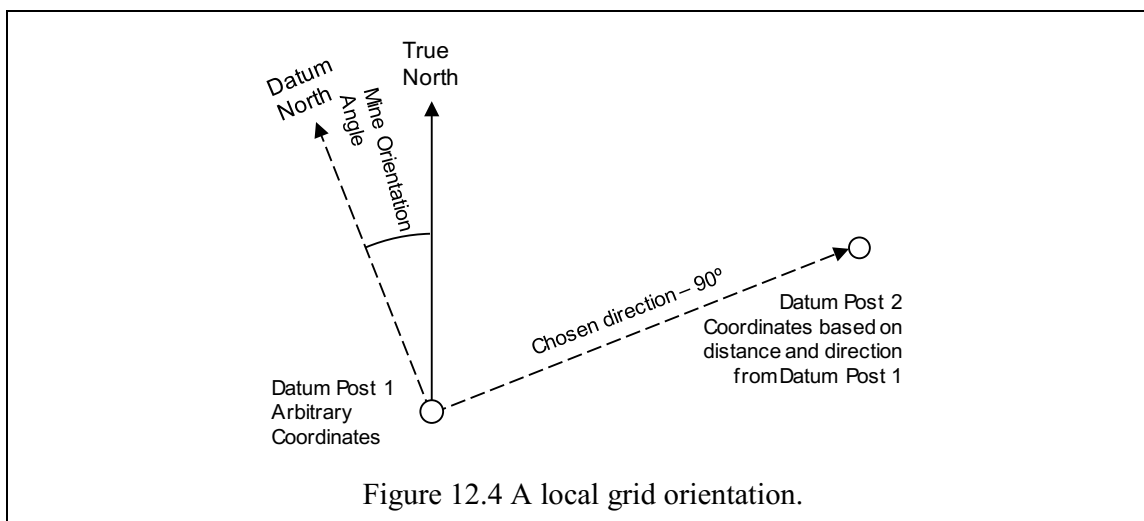

The most common Coordinate systems in use today within the mining industry today tend to be either:

- 1 The Map Grid of Australia 94 (MGA94), based on the 1994 Geodetic Datum of Australia from January 2000 onwards or,
- 2 Local Mine Grid, a plane grid system based on arbitrary coordinates and orientation.

However, if you are in Australia and are using data or information that precedes January 2000 then there are a number of other coordinate systems that could of been used apart from a Local Mine Grid. These systems are:

- 1 The Australian Map Grid 84 (AMG84) Coordinates, based on the 1984 Australian

Geodetic Datum. This coordinate system was the standard System from 1984 to until 1st January 2000 in Western Australia, South Australia and Queensland (Kirby 2010). This system was replaced with the MGA94 system after this date. Note that coordinates in this system will vary from an MGA94 coordinate of the same point by approximately 200m in a South Westerly direction.

- 2 Australian Map Grid 66 (AMG66) Coordinates. This system of coordinates replaced the individual State based systems in 1966 and was used up until the introduction of the AMG84 system in 1984, except NSW, Victoria and Tasmania. These states continued to use the AGD66 system up until 1st January 2000.
- 3 Coordinate systems predating 1966 were generally State or regionally based systems.

Given the number of coordinate systems in existence it is often a common requirement to be able to transform a set of points coordinates from one system to another. Invariable for mining or exploration areas set up after 1st January 2000 this will involve the transformation between MGA94 and the Local mine Grid system.

For small areas it is possible to use a 2 Dimensional Transformation based on 2 points having coordinates in either system. This allows the following parameters to be determined that can then be applied to convert coordinates from one system to the other.

- A) A rotation shift (θ) between the two systems.
- B) A datum shift, E_0 , N_0 , from one system to the other.
- C) A scale change (s) between the two systems.

This process gives rise to four transformation parameters (Uren et al, 2006) written as:

$$a = s \cos(\theta)$$

$$b = s \sin(\theta)$$

$$E_0 = \text{origin coordinate shift in E}$$

$$N_0 = \text{origin coordinate shift in N.}$$

These parameters can be determined by writing the relationship for two common coordinated points in terms of four equations:

$$e_1 = E_1 a - N_1 b + E_0$$

$$n_1 = N_1 a + E_1 b + N_0$$

$$e_2 = E_2 a - N_2 b + E_0$$

$$n_2 = N_2 a + E_2 b + N_0$$

These four equations can be used to solve for the four transformation parameters a , b , E_0 and N_0 . Once these four parameters are known they can then be used to convert any point in the secondary coordinate system to the primary coordinate system. These parameters can also be expressed as a , b , c , and d .

Any transformation parameters calculated will always be based on data from actual survey work so that any errors within either system will manifest themselves in the calculated parameters. This means that the transformation parameters are always going to be a “best fit” only. Any small errors in the transformation parameters resulting from the two survey systems will increase as you progress out from the datum points used.

Generally, it is good practice to calculate the transformation parameters based on points outside of the subject area. Always work from without to within. A minimum of 2 points is required to calculate the transformation parameters but it is always good practice to have 1 or 2

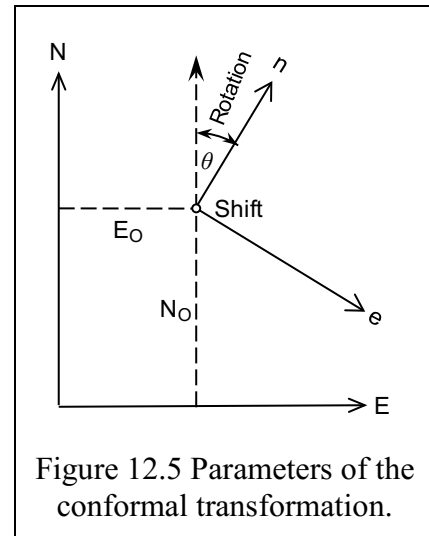

Figure 12.5 Parameters of the conformal transformation.

other dual coordinated points located outside the area to check the transformation parameter accuracies.

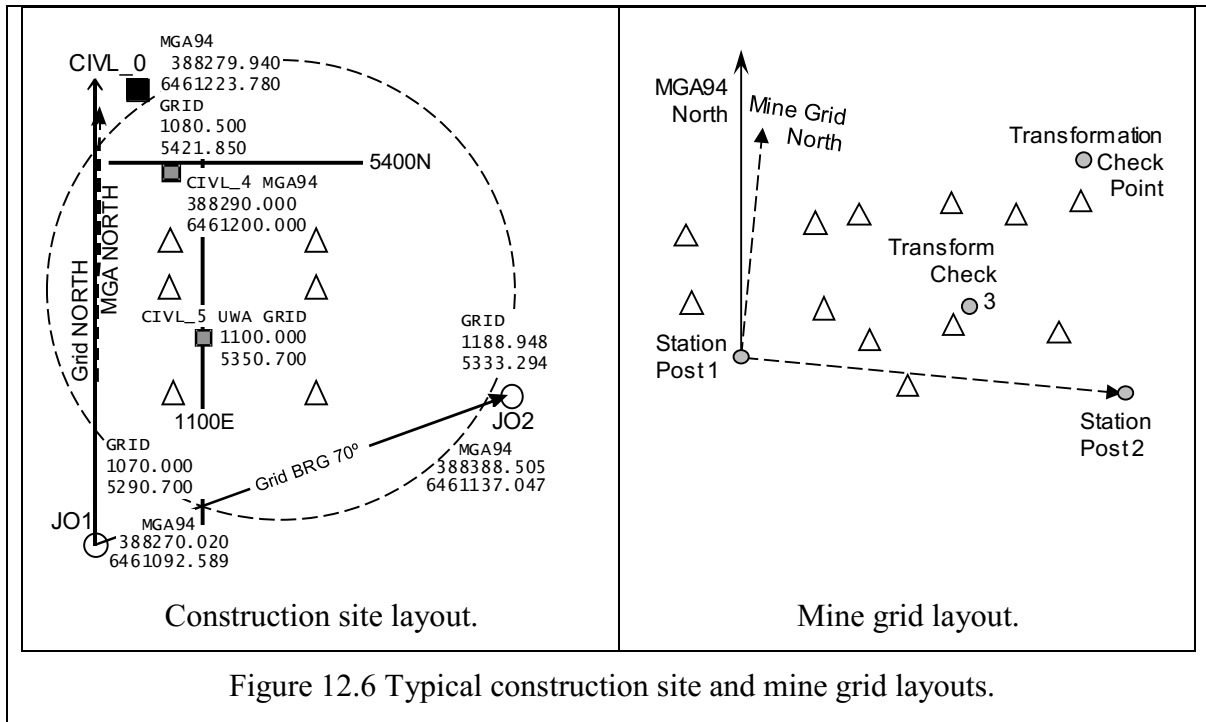

Figure 12.6 Typical construction site and mine grid layouts.

A two dimensional (2D) transformation described above can only be used over small areas of approximately 5 kilometres or less when converted from MGA94 coordinates to Local Mine Grid Coordinates or vice versa. Over large areas this type of transformation will not accurately model the scale variations of the MGA projection onto a “Flat Earth” system such as a Local Mine Grid system. In addition, these errors will increase in size as you move out from the central meridian of your MGA zone towards the zone boundary. Another source of error will be the height above the ellipsoid and variation of heights across the transformation area.

In Table 12-1 a transformation area having a uniform height over the area less than 370m above the ellipsoid and within 40km of the central meridian will have an error of 0ppm due to the transformation parameters used. In the case where the area in question ranges in height between 145m and 595m the errors associated with the transformation will be as much as 25ppm at some 50Km from the central meridian.

Table 12-1 Approximate maximum relative errors in parts per million (ppm) of a 2D Transformation based on the distance from the central meridian and height (ellipsoid) range over the area. Table Courtesy of Dr Michael Kuhn, Curtin University.

	0 ppm	5 ppm	10 ppm	15 ppm	20 ppm	25 ppm
0 km	170	125 – 215	80 – 260	35 – 305	10 – 350	55 – 395
10 km	180	135 – 225	90 – 270	45 – 315	0 – 360	45 – 405
20 km	200	155 – 245	110 – 290	65 – 335	20 – 380	25 – 425
30 km	245	200 - 290	155 – 335	110 – 380	65 - 425	20 – 470
40 km	300	255 - 345	210 - 390	165 – 435	120 - 480	75 – 525
50 km	370	325 - 415	280 - 460	235 – 505	190 - 550	145 – 595

The 2D transformation is only suitable over small areas reasonably close to the central meridian. If areas are larger or more accuracy is required then other types of coordinate transformations need to be used. The most rigorous and accurate transformation is the grid to file transformation that can deliver accuracies of between 0.02 to 0.2m. Information regarding this type of transformation, software and data grid files can be obtained from the Geoscience Australian website. (www.ga.gov.au)

Worked Example 12.1

Conformal transformation on a construction site.

A typical problem experienced is in an existing construction area where a local coordinate system has been used and you are surveying with GNSS to locate or set out points in terms of MGA94 coordinates.

Define a set of transformation parameters that will allow coordinate transformation between either system.

As discussed previously, a simple two dimensional transformation requires at least two (2) points with known coordinates in both systems. It is always good survey practice to have at least one more known point with coordinates in both systems to check the accuracy of your transformation parameters.

The given worked example is the determination of the transformation parameters required to change GNSS MGA94 coordinates in a local grid coordinates of Stations JO1 and JO2 into construction grid coordinates. Stations JO1 and JO2 are the original datum stations. The surveyor of the day set out his local baseline and assumed the bearing of the line JO1 to JO2 as 70°. Station 3 (CIVL_0) is a check point on site having both MGA94 coordinates and construction grid coordinates.

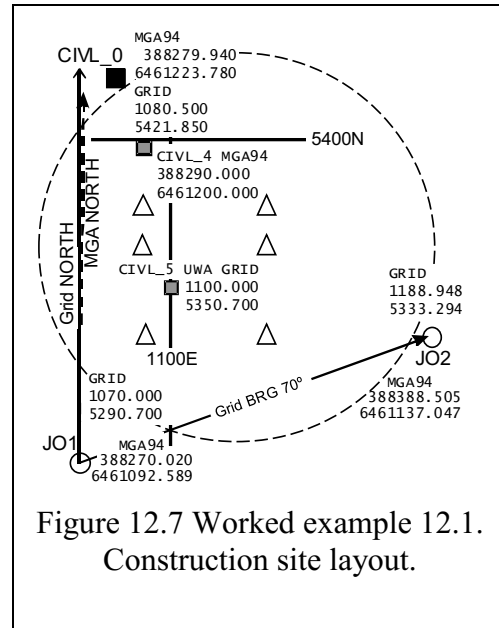

Figure 12.7 Worked example 12.1. Construction site layout.

Transform MGA94 coordinates to the construction grid.

Calculate the transformation parameters needed to transform other MGA coordinates to construction grid coordinates.

Table 12-2 Transformation data. Construction grid and corresponding MGA94 values.

Station		e_{mine}	n_{mine}	E_{MGA}	N_{MGA}
JO1	1	1070.000	5290.700	388270.020	6461092.589
JO2	2	1188.948	5333.294	388388.505	6461137.047
CIVL_0	3	1081.2	5421.1	388279.940	6461223.780

1: Using the coordinates for Station 1 and 2, (Table 12-2, Figure 12.7), set up the 4 transformation equations.

$$e_1 = E_1a - N_1b + E_0 \quad 1070.000 = 388270.020a - 6461092.589b + E_0 \quad (12.1)$$

$$n_1 = N_1a + E_1b + N_0 \quad 5290.700 = 6461092.589a + 388270.020b + N_0 \quad (12.2)$$

$$e_2 = E_2a - N_2b + E_0 \quad 1188.949 = 388388.505a - 6461137.047b + E_0 \quad (12.3)$$

$$n_2 = N_2a + E_2b + N_0 \quad 5333.294 = 6461137.047a + 388388.505b + N_0 \quad (12.4)$$

2: Subtract equation (3) from (1) and equation (4) from (2) to give:

$$-118.948 = -118.485a + 44.458b \quad (12.5)$$

$$-43.294 = -44.458a + (-118.485)b \quad (12.6)$$

3: Multiply Eqn 12.6 by a real number to make the **a** value or **b** value equal to the corresponding value in Eqn 12.5. In this case we have chosen the **b** to be the same in both Eqns 12.5 and 12.6.

$$\text{multiplication factor for } b = -\left(\frac{-44.458}{-118.485} = -0.3752205\right)$$

The value above is now multiplied to both sides of Eqn 12.6 to give Eqn 12.7.

$$\begin{aligned} -43.294 \times -0.3752205 &= -44.458 \times -0.3752205a - 118.485 \times -0.3752205b \\ 16.224796 &= 16.681553a + 44.458b \end{aligned} \quad (12.7)$$

4: Subtract Eqn 12.7 from Eqn 12.5 and solve for **a**.

$$\begin{aligned} \text{Eqn 12.5} & \quad -118.948 = -118.485a + 44.459b \\ \text{Eqn 12.7 Subtract} & \quad 16.224796 = 16.681553a + 44.458b \\ & \quad -135.193 = -135.166553a \end{aligned}$$

$$\mathbf{a} = \frac{-135.193}{-135.166553} = 1.00019416$$

5: Solve for **b** by substituting the value of **a** (1.00019416) in equation 12.5, 12.6 or 12.7.

$$\begin{aligned} \text{Now, Eqn 12.6 is} & \quad -43.294 = -44.458a + (-118.485)b \\ \text{Substitute } \mathbf{a} \text{ value:} & \quad -43.294 = -44.459 \times 1.00019416 + (-118.485)b \\ & \quad -43.294 = -44.4666318 + (-118.485)b \\ & \quad 1.17263 = -118.485b \end{aligned}$$

$$\mathbf{b} = \frac{1.17263}{-118.485} = -0.0098969$$

6: Solve for the shifts **E_O**, (c), and **N_O**, (d), using the calculated values of **a** and **b**. You can use either equations (1) and (2) for point one or equations (3) and (4) for point 2. A good check on the problem is to solve for both sets of equations and **check** to see that the **E_O** and **N_O** are the same for both points.

$$e_1 = E_1a - N_1b + E_O, \text{ re-arrange formula}$$

$$E_O = e_1 - E_1a + N_1b$$

$$\begin{aligned} E_O &= 1070.000 - 388270.020 \times 1.00019416 + 6461092.589 \times -0.0098969 \\ &= 1070.000 - 388345.405 + (-63944.655) \end{aligned}$$

$$\mathbf{E_O} = \mathbf{-451,220.060} \text{ (note this is a minus shift)}$$

$$n_1 = N_1a + E_1b + N_O, \text{ re-arrange formula}$$

$$N_O = n_1 - N_1a - E_1b$$

$$\begin{aligned} N_O &= 5290.000 - 6461092.589 \times 1.00019416 + 388270.020 \times -0.0094969 \\ &= 5290.000 - 6462347.046 - (-3842.662) \end{aligned}$$

$$\mathbf{N_O} = \mathbf{-6,453,214.385}$$

7: **Check.** The final step of the process should be a check of your transformation parameters using a third common point (CIVL_0).

$$\mathbf{a} = \mathbf{1.00019416} \quad \mathbf{b} = \mathbf{-0.0098969} \quad \mathbf{E_O} = \mathbf{-451,220.060} \quad \mathbf{N_O} = \mathbf{-6,453,214.385}$$

$$e_3 = E_3a - N_3b + E_O$$

$$\begin{aligned} &= 388279.940 \times 1.00019416 - 6461223.780 \times -0.0098969 + -451220.060 \\ &= 388355.327 - (-63945.953) + -451220.060 \end{aligned}$$

$$\mathbf{e_3} = \mathbf{1081.220} \quad \mathbf{error} \mathbf{-0.020}$$

$$n_3 = N_3a + E_3b + N_O$$

$$\begin{aligned} &= 6461223.78 \times 1.00019416 + 388279.94 \times -0.0098969 + (-6453214.385) \\ &= 6462478.263 + (-3842.760) + (-6453214.385) \end{aligned}$$

$$\mathbf{n_3} = \mathbf{5421.118} \quad \mathbf{error} \mathbf{-0.018}$$

Note: The check grid coordinates will always be a little different from the given surveyed coordinates. This is because of the small survey errors that exist in both coordinate networks.

The **rotation** of the construction grid from MGA94 can be determined from:

$$\theta = \text{Atan}\left(\frac{b}{a}\right) = \text{Atan}\left(\frac{-0.0098969}{1.00019416}\right) = \text{Atan}(-0.009894958) = -0.566921^\circ$$

$$\theta = -0^\circ 34' 01''$$

The **scale factor** between MGA94 and the construction grid can be determined from:

$$S = \left(\frac{a}{\cos\theta}\right) = \left(\frac{1.00019416}{\cos(-0^\circ 34' 01'')}\right) = \frac{1.00019416}{0.999951}, \text{ or}$$

$$S = \sqrt{a^2 + b^2} = \sqrt{1.00019416^2 + (-0.0098969)^2}$$

$$\mathbf{S = 1.0002431}$$

Thus, if any point is derived in MGA 94 it can be transformed into local coordinates.

Point CIVL_4 has been assigned MGA94 coordinates $E_4 = 388,290.000$, $N_4 = 6,461,200.000$.

What are its local coordinates (e_4 , n_4)?

$$\begin{aligned} e_4 &= E_4a - N_4b + E_0 \\ &= 388290.000 \times 1.00019416 - 6461200.000 \times -0.0098969 + -451220.060 \\ &= 388365.389 - (-63945.718) + -451220.060 \end{aligned}$$

$$\mathbf{e_4 = 1091.047}$$

$$\begin{aligned} n_4 &= N_4a + E_4b + N_0 \\ &= 6461200.000 \times 1.00019416 + 388290.000 \times -0.0098969 + (-6453214.385) \\ &= 6462454.478 + (-3842.859) + (-6453214.385) \end{aligned}$$

$$\mathbf{n_4 = 5397.234}$$

Transform Construction grid coordinates to MGA94.

Calculate the transformation parameters needed to transform other construction grid coordinates to MGA94.

1. To determine the transformation parameters for the opposite direction, construction grid to MGA94, the transformation equations need to be rewritten and solved as in the above example.

$$E_1 = e_1a - n_1b + e_0$$

$$N_1 = n_1a + e_1b + n_0$$

$$E_2 = e_2a - e_2b + e_0$$

$$N_2 = n_2a + n_2b + n_0$$

2. The parameters of the transformation, calculated as previously demonstrated, are:

$$\mathbf{a = 0.999708} \quad \mathbf{b = 0.0098921} \quad \mathbf{e_0 = 387,252.662} \quad \mathbf{n_0 = 6,455,793.549}$$

$$\mathbf{\theta = + 0^\circ 34' 01''} \quad (\text{same rotation as previous, opposite sign})$$

$$\mathbf{S = 0.9997569} \quad (\text{reciprocal of previous scale})$$

3. **Check.** Compare construction grid point **3** (CIVL_0, $e_3 = 1081.2$, $n_3 = 5421.1$) with corresponding MGA94 coordinates:

$$\begin{aligned} E_3 &= e_3a - n_3b + e_0 \\ &= 1081.5 \times 0.999708 - 5421.1 \times 0.00989207 + 387252.662 \\ &= 1080.884 - 53.626 + 387252.662 \end{aligned}$$

$$\mathbf{E_3 = 388,279.920} \quad \mathbf{error 0.020}$$

$$\begin{aligned} N_3 &= n_3a + e_3b + n_0 \\ &= 5421.1 \times 0.999708 + 1081.5 \times 0.00989207 + 6455793.549 \\ &= 5419.517 + 10.695 + 6455793.549 \end{aligned}$$

$$\mathbf{N_3 = 6,461,223.762} \quad \mathbf{error 0.018}$$

Note the small survey errors that exist in both coordinate networks.

Using the derived parameters, any local point can be transformed to MGA94 coordinates.

Transform another point.

Point CIVL_5 has been assigned local coordinates $e_5 = 1100.000$, $n_5 = 5350.000$. What are its MGA94 coordinates?

$$E_5 = e_5a - n_5b + e_0$$

$$= 1100.0 \times 0.999708 - 5350.0 \times 0.00989207 + 387252.662$$

$$= 1099.679 - 52.923 + 387252.662$$

$E_5 = 388,299.418$

$$N_5 = n_5a + e_5b + n_0$$

$$= 5350.0 \times 0.999708 + 1100.0 \times 0.00989207 + 6455793.549$$

$$= 5348.437 + 10.881 + 6455793.549$$

$N_5 = 6,461,152.868$

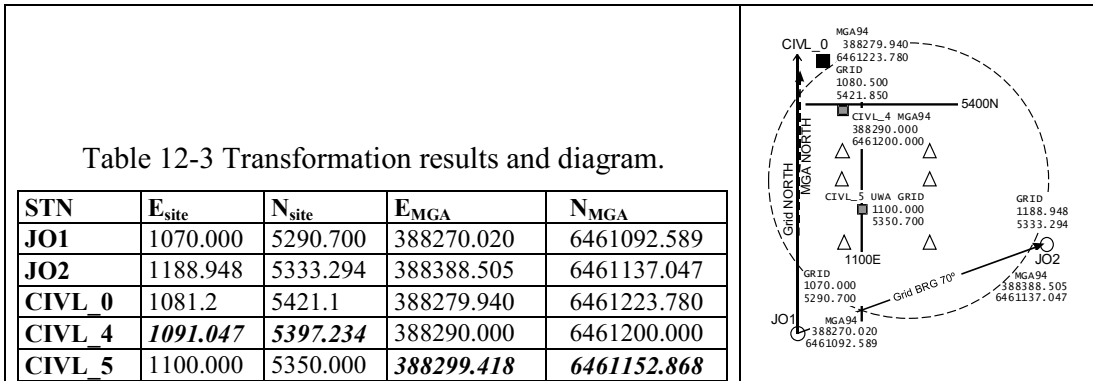

12.3.3 A Matrix Method Approach to Coordinate Transformations - the Unique Solution

Transform mine grid coordinates to MGA94. The following worked example is the determination of the transformation parameters required to change GNSS MGA94 coordinates in a local mine grid coordinates. As shown in Figure 12.8 of the mine plan, station 1 and station 2 are the original mine datum stations. The surveyor of the day set out his baseline approximately east and defined the bearing of the line as 90° . Station 3 is another point on site having both MGA94 coordinates and Mine Grid coordinates. An extra transformation check point has been provided.

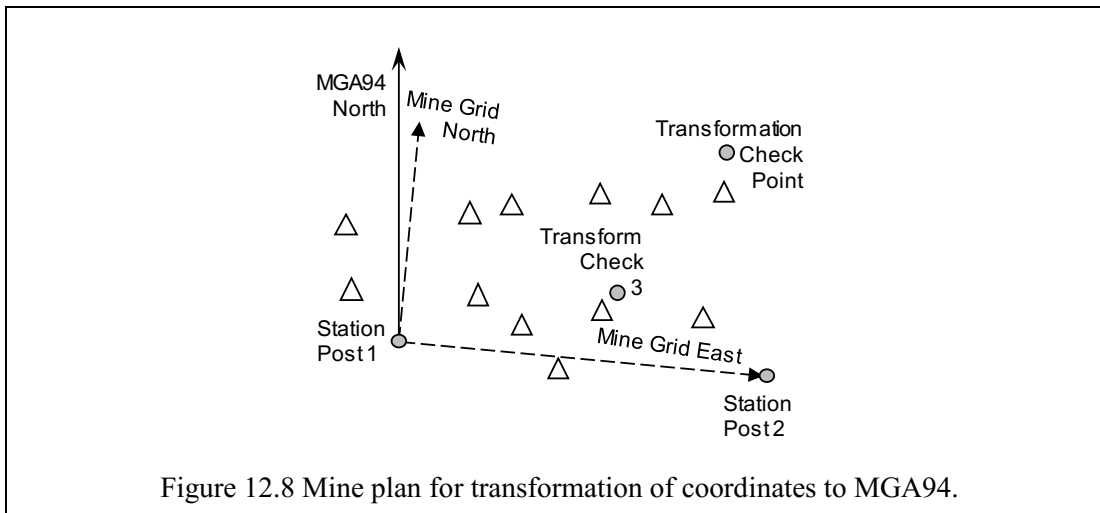

Figure 12.8 Mine plan for transformation of coordinates to MGA94.

Whilst the preceding Worked Example 12.1 was a direct solution of a unique conformal transformation, a matrix method is introduced to solve the unique solution. It will form the basis of a Least Squares solution of an over-determined transformation, from the simple conformal to the Affine and beyond.

4. Because there are no residuals (unique solution) we have the matrix:

$$\mathbf{A} \cdot \mathbf{x} = \mathbf{b} \quad \text{then:}$$

$$\mathbf{x} = \mathbf{A}^{-1} \cdot \mathbf{b} \quad (\mathbf{A} \text{ inverse } \times \mathbf{b})$$

The A matrix is a 4 x 4 and is a major exercise to invert by hand. Using the **Matlab** `=inv(A)`, or Microsoft **Excel** the inversion routine `{=MINVERSE(A11:A44)}` produces A inverse (displayed to 6DP).

$$\mathbf{A}^{-1} = \begin{vmatrix} -0.000805 & 8.766838^{-5} & 0.000805 & -8.766838^{-5} \\ -8.766838^{-5} & -0.000805 & 8.766838^{-5} & 0.000805 \\ -260.969573 & -5232.220538 & 261.969573 & 5232.220538 \\ 5232.220538 & -260.969573 & -5232.220538 & 261.969573 \end{vmatrix}$$

5. Now find the x (4 x 1) matrix: $\mathbf{x} = \mathbf{A}^{-1} \cdot \mathbf{b}$ (4 x 4) x (4 x 1) = (4 x 1)

$$\mathbf{A}^{-1} \begin{vmatrix} -0.000805 & 8.766838^{-5} & 0.000805 & -8.766838^{-5} \\ -8.766838^{-5} & -0.000805 & 8.766838^{-5} & 0.000805 \\ -260.969573 & -5232.220538 & 261.969573 & 5232.220538 \\ 5232.220538 & -260.969573 & -5232.220538 & 261.969573 \end{vmatrix} \cdot \mathbf{b} \begin{vmatrix} 50000.000 \\ 125000.000 \\ 51235.300 \\ 125000.000 \end{vmatrix}$$

$$\{x_{11}:x_{41}\} = \{\text{MMULT}(\text{MINVERSE}(A_{11}:A_{44}), b_{11}:b_{41})\}$$

$$\mathbf{x} = \begin{vmatrix} a & 0.994363 \\ b & 0.108297 \\ E_O & 373611.013 \\ N_O & -6338362.031 \end{vmatrix}$$

6. And the rotation:

$$\theta = \text{Atan}\left(\frac{b}{a}\right) = \text{Atan}\left(\frac{0.108297}{0.994363}\right) = \text{Atan}(0.1089109) = 6.215638^\circ$$

$$\theta = 6^\circ 12' 56''$$

7. Find the scale factor from:

$$S = \sqrt{a^2 + b^2} = \sqrt{0.994363^2 + 0.108297^2}$$

$$S = 1.000243$$

8. Calculating the coordinates of point 3, using coefficients of observations (MGA94 coordinates of Station 3):

$$\begin{aligned} e_3 &= E_3a - N_3b + E_O + 0N_O & \mathbf{A}_3 & \begin{vmatrix} 378695.153 & -6458984.707 & 1 & 0 \\ 6458984.707 & 378695.153 & 1 & 0 \end{vmatrix} \\ n_3 &= N_3a + E_3b + 0E_O + N_O \end{aligned}$$

$$\text{Result Matrix} = \mathbf{A}_3 \cdot \mathbf{x} \quad \{a_{11}:a_{21}\} = \{\text{MMULT}(A_{311}:A_{324}, x_{11}:x_{41})\}$$

$$e_3 = 50,684.403 \quad (\text{error } 0.018)$$

$$n_3 = 125,224.722 \quad (\text{error } 0.005)$$

Reversing the transformation. Mine grid to MGA94.

To determine the transformation parameters for the opposite direction, Local Mine Grid to MGA94, the transformation equation need to be rewritten and solved as in the preceding example.

The formulæ are (from W.E. 12.1) and the A matrix of coefficients is:

$$\mathbf{A} = \begin{matrix} & \text{(point)} & a & b & e_O & n_O \\ \begin{matrix} E_1 = e_1a - n_1b + e_O \\ N_1 = n_1a + e_1b + n_O \\ E_2 = e_2a - e_2b + e_O \\ N_2 = n_2a + n_2b + n_O \end{matrix} & \begin{matrix} 1 \\ 1 \\ 2 \\ 2 \end{matrix} & \begin{matrix} e_1 \\ n_1 \\ e_2 \\ n_2 \end{matrix} & \begin{matrix} -n_1 \\ e_1 \\ -n_2 \\ e_2 \end{matrix} & \begin{matrix} E_O \\ 0 \\ E_O \\ 0 \end{matrix} & \begin{matrix} 0 \\ N_O \\ 0 \\ N_O \end{matrix} \end{matrix}$$

1. Form the A (4 x 4) matrix of the observation coefficients for e and n in the mine system.

The solution comprises the control points 1 and 2, considered **fixed**.

$$\mathbf{A} = \begin{array}{l|ll} & \mathbf{a} & \mathbf{b} & \mathbf{e}_O & \mathbf{n}_O \\ \hline \mathbf{E}_1 & 50000 & -125000 & 1 & 0 \\ \mathbf{N}_1 & 125000 & 50000 & 0 & 1 \\ \mathbf{E}_2 & 51235.3 & -125000 & 1 & 0 \\ \mathbf{N}_2 & 125000 & 51235.3 & 0 & 1 \end{array}$$

2. Form the \mathbf{b} matrix (4 x 1); the matrix of the observed coordinates in the **MGA** system.

$$\mathbf{b} = \begin{array}{l|l} \mathbf{E}_1 & 377990.614 \\ \mathbf{N}_1 & 6458835.443 \\ \mathbf{E}_2 & 379218.354 \\ \mathbf{N}_2 & 6458701.729 \end{array}$$

3. Because there are no residuals (unique solution) we have the matrix:

$$\mathbf{A} \cdot \mathbf{x} = \mathbf{b}, \text{ then:}$$

$$\mathbf{x} = \mathbf{A}^{-1} \cdot \mathbf{b}$$

4. Now find the \mathbf{x} (4 x 1) matrix: $\mathbf{x} = \mathbf{A}^{-1} \cdot \mathbf{b}$ (4 x 4) x (4 x 1) = (4 x 1)

$$\{\mathbf{x}_{11}:\mathbf{x}_{41}\} = \{\text{MMULT}(\text{MINVERSE}(\mathbf{A}_{11}:\mathbf{A}_{44}), \mathbf{b}_{11}:\mathbf{b}_{41})\}$$

$$\mathbf{x} = \begin{array}{l|l} \mathbf{a} & 0.993880 \\ \mathbf{b} & -0.108244 \\ \mathbf{e}_O & 314766.094 \\ \mathbf{n}_O & -6340012.647 \end{array}$$

The parameters of the transformation are:

$$\mathbf{a} = \mathbf{0.993880} \quad \mathbf{b} = -\mathbf{0.108244} \quad \mathbf{e}_O = \mathbf{314,766.094} \quad \mathbf{n}_O = \mathbf{6,340,012.647}$$

$$\theta = -\mathbf{6^\circ 12' 56''} \quad (\text{same rotation as previous, opposite sign})$$

$$\mathbf{S} = \mathbf{0.999757} \quad (\text{reciprocal of previous scale})$$

5. Calculating the coordinates of point **3**, using coefficients of observations (MINE coordinates of Station 3):

$$\begin{array}{l} \mathbf{E}_3 = \mathbf{e}_3\mathbf{a} - \mathbf{n}_3\mathbf{b} + \mathbf{e}_O + 0\mathbf{n}_O \\ \mathbf{N}_3 = \mathbf{n}_3\mathbf{a} + \mathbf{e}_3\mathbf{b} + 0\mathbf{e}_O + \mathbf{n}_O \end{array} \quad \mathbf{A}_3 = \begin{array}{l|llll} & 50684.385 & -125224.717 & 1 & 0 \\ & 125224.717 & 50684.385 & 1 & 0 \end{array}$$

$$\mathbf{Result Matrix} = \mathbf{A}_3 \cdot \mathbf{x} \quad \{\mathbf{a}_{11}:\mathbf{a}_{21}\} = \{\text{MMULT}(\mathbf{A}_{3_{11}}:\mathbf{A}_{3_{24}}, \mathbf{x}_{11}:\mathbf{x}_{41})\}$$

$$\mathbf{E}_3 = \mathbf{378,695.135} \quad (\text{error } \mathbf{0.018})$$

$$\mathbf{N}_3 = \mathbf{6,458,984.704} \quad (\text{error } \mathbf{0.003})$$

Note the small survey errors that exist in both coordinate networks.

12.3.4 Least Squares Solution to Coordinate Transformation

Taking the original conformal transformation, and introducing the third point, Station 3, the transformation becomes over-determined because there are more coefficients, six (6), than the minimum four (4) transformation parameters required. We saw a small transformation error between our forward and backward solutions in Worked Example 12.2. Now we will distribute that error to provide a better estimate of the transformation parameters (\mathbf{a} , \mathbf{b} , \mathbf{E}_O , \mathbf{N}_O) to allow a “better” solution of unknown transformation points.

The formulae are (modified from W.E. 12.1) and the \mathbf{A} matrix of coefficients is:

$$\begin{array}{l} \mathbf{e}_1 = \mathbf{E}_1\mathbf{a} - \mathbf{N}_1\mathbf{b} + \mathbf{E}_O + 0\mathbf{N}_O \\ \mathbf{n}_1 = \mathbf{N}_1\mathbf{a} + \mathbf{E}_1\mathbf{b} + 0\mathbf{E}_O + \mathbf{N}_O \\ \mathbf{e}_2 = \mathbf{E}_2\mathbf{a} - \mathbf{N}_2\mathbf{b} + \mathbf{E}_O + 0\mathbf{N}_O \\ \mathbf{n}_2 = \mathbf{N}_2\mathbf{a} + \mathbf{E}_2\mathbf{b} + 0\mathbf{E}_O + \mathbf{N}_O \\ \mathbf{e}_3 = \mathbf{E}_3\mathbf{a} - \mathbf{N}_3\mathbf{b} + \mathbf{E}_O + 0\mathbf{N}_O \\ \mathbf{n}_3 = \mathbf{N}_3\mathbf{a} + \mathbf{E}_3\mathbf{b} + 0\mathbf{E}_O + \mathbf{N}_O \end{array} \quad \mathbf{A} = \begin{array}{l|llll} & \text{(point)} & \mathbf{a} & \mathbf{b} & \mathbf{E}_O & \mathbf{N}_O \\ \hline & 1 & \mathbf{E}_1 & -\mathbf{N}_1 & \mathbf{E}_O & 0 \\ & 1 & \mathbf{N}_1 & \mathbf{E}_1 & 0 & \mathbf{N}_O \\ & 2 & \mathbf{E}_2 & -\mathbf{N}_2 & \mathbf{E}_O & 0 \\ & 2 & \mathbf{N}_2 & \mathbf{E}_2 & 0 & \mathbf{N}_O \\ & 3 & \mathbf{E}_3 & -\mathbf{N}_3 & \mathbf{E}_O & 0 \\ & 3 & \mathbf{N}_3 & \mathbf{E}_3 & 0 & \mathbf{N}_O \end{array}$$

This solution is non-unique, using three points, so there will be residual errors. There will be a \mathbf{v} matrix.

Worked Example 12.3. Over-determined Least Squares Conformal Transformation.

The use of Microsoft Excel™ to solve these problems

1. Form the \mathbf{x} matrix of the parameters of the transformed points X:

$$\mathbf{x} = \begin{array}{|c|} \hline a \\ \hline b \\ \hline E_0 \\ \hline N_0 \\ \hline \end{array} \quad \text{is a } 4 \times 1 \text{ matrix}$$

2. Form the \mathbf{A} (6 x 4) matrix of the observation coefficients for E and N.

The solution comprises the control points 1, 2 and 3, considered **fixed**.

$$\mathbf{A} = \begin{array}{|c|c|c|c|c|} \hline & a & b & E_0 & N_0 \\ \hline E_1 & 377990.614 & -6458835.443 & 1 & 0 \\ \hline N_1 & 6458835.443 & 377990.614 & 0 & 1 \\ \hline E_2 & 379218.354 & -6458701.729 & 1 & 0 \\ \hline N_2 & 6458701.729 & 379218.354 & 0 & 1 \\ \hline E_3 & 378695.153 & -6458984.707 & 1 & 0 \\ \hline N_3 & 6458984.707 & 378695.153 & 0 & 1 \\ \hline \end{array}$$

3. Form the \mathbf{b} matrix (6 x 1); the matrix of the observed coordinates in the **Mine** system.

$$\mathbf{b} = \begin{array}{|c|c|} \hline e_1 & 50000.000 \\ \hline n_1 & 125000.000 \\ \hline e_2 & 51235.300 \\ \hline n_2 & 125000.000 \\ \hline e_3 & 50684.385 \\ \hline n_3 & 125224.717 \\ \hline \end{array}$$

4. Because there are now residuals (over-determined solution) we have to generate the \mathbf{v} matrix (6 x 1) of residuals, \mathbf{v} , (Greek letter, nu).

$$\mathbf{v} = \begin{array}{|c|c|} \hline e_1 & v e_1 \\ \hline n_1 & v n_1 \\ \hline e_2 & v e_2 \\ \hline n_2 & v n_2 \\ \hline e_3 & v e_3 \\ \hline n_3 & v n_3 \\ \hline \end{array}$$

5. Solve the matrix $\mathbf{A} \cdot \mathbf{x} = \mathbf{b} + \mathbf{v}$.

The matrix must first be **normalised** to the form by using the **transpose** of \mathbf{A} , \mathbf{A}^T :

$$\mathbf{A}^T \cdot \mathbf{A} \cdot \mathbf{x} = \mathbf{A}^T \cdot \mathbf{b}, \quad \text{then, minimising } \mathbf{A}^T \mathbf{A} \text{ by least squares, leads to:}$$

$$\hat{\mathbf{x}} = (\mathbf{A}^T \mathbf{A})^{-1} \cdot \mathbf{A}^T \mathbf{b} \quad (\text{Invert}(\mathbf{A}^T \mathbf{A}) \text{ times } (\mathbf{A}^T \mathbf{b}))$$

The generation of the $\mathbf{A}^T \cdot \mathbf{A}$ matrix (4 x 6) x (6 x 4) is a 4 x 4 and is a major exercise to calculate, then invert, by hand. Using Microsoft **Excel**, the matrix transpose, multiplication and inversion routines produce (note that this can also be done in algebraic software such as MATLAB or Mathematica):

$$\mathbf{A}^T \mathbf{A} = \begin{array}{|c|c|c|c|c|} \hline & 1.2558^{14} & 0 & 1135904.121 & 19376521.88 \\ \hline & 0 & 1.2558^{14} & -19376521.88 & 1135904.121 \\ \hline & 1135904.121 & -19376521.88 & 3 & 0 \\ \hline & 19376521.88 & 1135904.121 & 0 & 3 \\ \hline \end{array}$$

6. Find the \mathbf{N}^{-1} (inverse) matrix: (\mathbf{N} inverse being the inverse of $\mathbf{A}^T \cdot \mathbf{A}$).

$$\{\mathbf{N}^{-1}_{11} : \mathbf{N}^{-1}_{41}\} = \{\text{MINVERSE}(\text{MMULT}(\text{TRANSPOSE}(\mathbf{A}_{11} : \mathbf{A}_{64}), \mathbf{A}_{11} : \mathbf{A}_{64}))\}$$

$$\begin{array}{l}
 (\mathbf{A}^T \mathbf{A})^{-1} \\
 = \mathbf{N}^{-1}
 \end{array}
 \left| \begin{array}{cccc}
 1.2512^{-6} & 1.101607^{-15} & -0.4737483 & -8.081310 \\
 -2.5362^{-15} & 1.2512^{-6} & 8.081310 & -0.4737483 \\
 -0.4737483 & 8.081310 & 52375271.9 & 0.07613824 \\
 -8.081310 & -0.4737483 & -0.07613824 & 52375271.4
 \end{array} \right|$$

7. Now find the $\mathbf{A}^T \cdot \mathbf{b}$ (4 x 1) matrix:

$$\mathbf{A}^T \cdot \mathbf{b}
 \left| \begin{array}{c}
 2.48104\text{E}+12 \\
 -8.39152\text{E}+11 \\
 151919.685 \\
 375224.717
 \end{array} \right|$$

8. Finally the \mathbf{x} (4 x 1) matrix: $\mathbf{x} = \mathbf{N}^{-1} \cdot \mathbf{A}^T \cdot \mathbf{b}$ (4 x 4) x (4 x 1) = (4 x 1)

$$\begin{array}{l}
 \{x_{11}:x_{41}\} \\
 \mathbf{x} = \begin{array}{l} a \\ b \\ E_O \\ N_O \end{array}
 \end{array}
 \left| \begin{array}{c}
 = \{\text{MMULT}(\mathbf{N}^{-1}_{11}:\mathbf{N}^{-1}_{44}), \mathbf{A}^T \mathbf{b}_{11}:\mathbf{A}^T \mathbf{b}_{41}\} \\
 0.994361 \\
 0.108300 \\
 373630.072 \\
 -6338348.973
 \end{array} \right|$$

9. And the rotation:

$$\theta = \text{Atan}\left(\frac{b}{a}\right) = \text{Atan}\left(\frac{0.108300}{0.994361}\right) = \text{Atan}(0.1089142) = 6.215821^\circ$$

$$\theta = 6^\circ 12' 57''$$

10. Find the scale factor from:

$$S = \sqrt{a^2 + b^2} = \sqrt{0.994361^2 + 0.108300^2}$$

$$\mathbf{S} = 1.000241$$

11. Calculating the adjusted coordinates of the three points, using coefficients of observations. (MGA94 coordinates of the stations) provides the adjusted coordinates and their residuals:

Result Matrix: $\mathbf{b}_{\text{calc}} = \mathbf{A} \cdot \mathbf{x}$ $\mathbf{V} = \mathbf{b}_{\text{obs}} - \mathbf{b}_{\text{calc}}$ (residuals)

$$\begin{array}{l}
 e_1 \\
 n_1 \\
 e_2 \\
 n_2 \\
 e_3 \\
 n_3 \\
 \text{SUM}
 \end{array}
 \left| \begin{array}{cc}
 49999.996 & 0.004 \\
 124999.997 & 0.003 \\
 51235.293 & 0.007 \\
 125000.001 & -0.001 \\
 50684.396 & -0.011 \\
 125224.721 & -0.004 \\
 -0.002 &
 \end{array} \right|$$

This is the sum of the residuals, close to zero.

12. Calculate the adjusted mine grid coordinates of the MGA94 check point, which should have previously observed mine grid coordinates:

The \mathbf{A}_{ck} (6 x 4) matrix of the observation coefficients for E and N is:

$$\mathbf{A} = \begin{array}{l} E_{\text{ck}} \\ N_{\text{ck}} \end{array}
 \left| \begin{array}{ccc}
 & a & b & E_O & N_O \\
 377990.614 & -6458835.443 & 1 & 0 \\
 6458835.443 & 377990.614 & 0 & 1
 \end{array} \right|$$

Result matrix: $\mathbf{b}_{\text{calc}} = \mathbf{A} \cdot \mathbf{x}$

$$\begin{array}{l}
 e_{\text{ck}} \\
 n_{\text{ck}}
 \end{array}
 \left| \begin{array}{c}
 50980.705 \\
 125717.493
 \end{array} \right|$$

The use of MATLAB to solve the problems.

Your course will introduce you to the MATLAB environment as a programming and problem solving tool. There are many excellent books on the subject; there is plenty of expertise around the Spatial Science departments.

Compare the spreadsheet solution with the MATLAB solution in parallel.

Using MATLAB as a matrix calculator (Worked Example 12.3):

We will use the comma (,) as the variable separator, although a space or a tab will do the same.

Entry of a multi-dimensional matrix requires the use of the Enter key at the end of each line;

using the symbol \leftarrow to denote the  key.

Refer to the matrix formation on the spreadsheet page.

1. Form the \mathbf{A} (6 x 4) matrix of the observation coefficients for E and N.

The solution comprises the control points 1, 2 and 3, considered **fixed**.

Enter the a, b, E_0 , N_0 coefficients for each row:

```
EDU>> A = [ 377990.614, -6458835.443, 1, 0  $\leftarrow$ 
6458835.443, 377990.614, 0, 1  $\leftarrow$ 
379218.354, -6458701.729, 1, 0  $\leftarrow$ 
6458701.729, 379218.354, 0, 1  $\leftarrow$ 
378695.153, -6458984.707, 1, 0  $\leftarrow$ 
6458984.707, 378695.153, 0, 1];  $\leftarrow$ 
```

Note a) the matrix is initiated with an opening square bracket [

b) the matrix is finalized with an closing square bracket]

c) the semi-colon, ;, after the closing bracket suppresses the display of the \mathbf{A} matrix.

2. Form the \mathbf{b} matrix (6 x 1); the matrix of observed coordinates in the **Mine** system. (\mathbf{b}_{obs})

```
EDU>> b = [ 50000  $\leftarrow$ 
125000  $\leftarrow$ 
51235.3  $\leftarrow$ 
125000  $\leftarrow$ 
50684.385  $\leftarrow$ 
125224.717];  $\leftarrow$ 
```

3. Solve the matrix $\mathbf{A} \cdot \mathbf{x} = \mathbf{b} + \mathbf{v}$.

The matrix must first be **normalised** to the form:

$$\mathbf{A}^T \mathbf{A} \cdot \mathbf{x} = \mathbf{A}^T \mathbf{b} + \mathbf{v}, \text{ then}$$

$$\mathbf{x} = (\mathbf{A}^T \mathbf{A})^{-1} \cdot \mathbf{A}^T \mathbf{b} + \mathbf{v}$$

The \mathbf{x} and the \mathbf{v} matrix can be handled as normal calculations.

```
EDU>>x = (inv(A'*A))* (A'*b)  $\leftarrow$ 
```

Note a) the **inv(A'*A)** function finds the inverse of the bracketed expression,

b) \mathbf{A}' (\mathbf{A} prime) is the **transpose** of the \mathbf{A} matrix,

c) no semi-colon, the \mathbf{x} vector (matrix) is displayed to 4 dp with scaling,

d) extra (unnecessary) brackets have been included for clarity.

$\mathbf{x} =$

1.0e+006 *	The answers to 4 or 3dp derived from format long
0.0000	a 0.9944
0.0000	b 0.1083
0.3736	E₀ 373630.072
-6.3383	N₀ -6338348.973

4. Find the rotation in radians: $\theta = \text{Atan}\left(\frac{b}{a}\right)$

```
EDU>>Rotation = atan(x(2)/x(1))  $\leftarrow$  define Rotation: x(2) = b, x(1) = a
Rotation =
```

0.1085 radians, to be converted to degrees.

```
EDU>>R_degree = Rotation * 180/pi  $\leftarrow$ 
```

R_degrees =
6.2158 | $\theta = 6^\circ 12' 57''$

5. And the scale factor, $SF = \sqrt{a^2 + b^2}$, define SF using the **norm(vector)** function.

EDU>>SF = norm(x(1:2)) ← x(1:2) represents the first two elements, **a** and **b**, of **x** vector.

1.0002 | SF = 1.000241

6. Calculate the adjusted coordinates of the three points, **b_{calc}**

Result Matrix: **b_{calc} = A·x**

EDU>> bcalc = A*x ← define b_{calc}, adjusted values of transformed coordinates.

bcalc =
1.0e+005 * | These are the values to 3dp.
0.5000 | e₁ 49999.996
1.2500 | n₁ 124999.997
0.5124 | e₂ 51235.293
1.2500 | n₂ 125000.000
0.5068 | e₃ 50684.396
1.2522 | n₃ 125224.720

7. Calculate the residuals.

Residuals matrix: **v = b - b_{calc} (residuals)**

EDU>> v = b-bcalc ← define v, residuals between observed and calculated coordinates.

v =
0.0045
0.0034
0.0068
-0.0003
-0.0113
-0.0031

8. Check that the sum of the residuals vector is a minimum.

EDU>> sumv = sum(v) ←
sumv =

0.0000 | Sum residuals.

12.4 Coordinate Translations – a VERY HELPFUL Technique

You will have noted that working in MGA coordinates, and even in the Local Mine Grid, that you have some serious numbers to manipulate. Used directly in the program, these numbers are well outside the capability of even a 12 digit calculator. In fact, Microsoft Excel introduces errors, even with its 16 digit computations.

What to do? Translate the axes of one or both coordinate systems. That's what!

Why use numbers like E378,000, N6,500,000 (MGA) when the work area is only covering an area of dE < 1,300 and dN < 300? Why not move (translate) the ORIGIN up close to the work site?

1. This is the original data (Table 12-5):

Station	e _{mine}	n _{mine}	E _{MGA}	N _{MGA}
Post 1	50000.000	125000.000	377990.614	6458835.443
Post 2	51235.300	125000.000	379218.354	6458701.729
3	50684.385	125224.717	378695.153	6458984.707

By examination we can choose some minimum numbers for both systems that will leave the system in the first quadrant:

False origin mine False origin MGA
 e_{mine} 50000 E_{MGA} 377,900
 n_{mine} 125000 N_{MGA} 6,458,700

2. Subtracting BOTH sets of false origins, the TRANSLATED coordinates are (Table 12-6):

Station	e_{mine}	n_{mine}	E_{MGA}	N_{MGA}
Post 1	0.000	0.000	390.614	135.443
Post 2	1235.300	0.000	1318.354	11.729
3	684.385	224.717	795.153	284.707

Interesting things now happen:

The x_{orig} matrix was: becomes translated x_{shift} :

$x =$	a	0.994361	a	0.994361
	b	0.108300	b	0.108300
	E_O	373630.072	E_O	-75.439
	N_O	-6338348.973	N_O	-144.496

There is almost no change for scale factor, s , or the rotation, θ .
 However, the shifts, E_O and N_O , are much nicer to deal with.

But it is the residuals that provide food for thought:

The original residual the transformed translated coordinates residuals are:

	V_{orig}		b_{calc}		V_{shift}
e_1	0.004		49999.996		0.004
n_1	0.003		124999.997		0.003
e_2	0.007		51235.293		0.007
n_2	-0.001		125000.000		0.000
e_3	-0.011		50684.396		-0.011
n_3	-0.004		125224.720		-0.003
SUM	-0.002				0.000

This shows that some errors have crept into the original transformation because of computational limitations of the Excel program.

Using a 12 digit calculator on the original problem would have provided meaningless answers, even those programmed to do least squares adjustments.

3. **Finally ADD the false origins to the transformed points. This returns you to the original reference frame.**

Note that computational limits did not arise in MATLAB.

12.5 Resection to a Point by EDM – a Least Squares Solution

Modern positioning methods using Total Stations use the intersection from known points to the unknown observation point occupied by the TS.

Resection is also a function found in all TS software and this section is intended as an introduction to the method of resection - including a least squares solution - to calculate the most likely unknown station.

A Total Station measures distances and directions directly to targets set over known points.

Recalling Section 6.3.2, intersection by distances, direct solution, it can be seen that a Total Station will give horizontal distances to two known points. The unknown point can be calculated directly.

However, the TS also shows directions. The **directions** to the known points thus form the **angle** from the observation point to the two known points.

Whilst we may consider this angle to be **redundant** information (it isn't used in the solution by distances); it can still be used as a check of our calculations. By calculating the directions from the solved unknown point to the two known points we can get the included angle at the unknown point.

But, more than a check, it can now be included in the solution of the unknown coordinates so that the coordinate values we calculate are as close to the true value as we can make, and prove, them from ALL in information available.

The method we use is the method of **Least Squares** where the sum of the squares of the differences between the calculated and the true values, the **residuals**, is a minimum. From this information we can further derive information about the "accuracy" of our observations, the standard deviations.

Most least squares solutions are beyond the scope of hand calculation. Surveyors will be introduced to least squares software in later years of their course. The software will do the work for them. However this section, with a simple problem, will be solved manually using matrix manipulation to show the process.

The ability to understand and manipulate matrices is, along with partial differentiation and linearization of functions, vital to the understanding of least squares solution. **Matlab** will be the software of instruction for matrix work. Microsoft **Excel** can also manipulate matrices, as long as you know the rules, and aren't too ambitious.

This section will use either hand calculation of matrices (up to 3 x 3) or Excel for larger systems. The calculations will be performed in 2D space (X, Y or E, N), however 3D space (Z or height) can be relatively easily incorporated.

All the calculations have been made in Microsoft Excel to full precision and then displayed as shown. The numbers have not been truncated.

The basic structure of the solutions presented comes from Schofield and Breach, 2007 and WAIT, 1982

12.5.1 Resection by Observation from an Unknown Point to Two Known Points

In Figure 12.9 the adjusted coordinates of X are to be calculated from the following observations:

Control A E1000.000, N5000.000, fixed
points B E1160.000, N5190.000, fixed

At station X the following **observations**
were made:

XA = 304.864 ± 0.01m (H distance)

XB = 295.055 ± 0.01m (H distance)

$\angle AXB = 48^\circ 53' 15'' \pm 10''$

Initial coordinates for X have been calculated from the method described in Section 6.3.2, intersection by distances. Figure 12.9 has been annotated to help you confirm the coordinates of X (point 1),

Initial values for calculation:

X E1281, N4910.

The most likely values of the X coordinates are:

$E_X = e_x + \delta E_X$ the initial values + small error

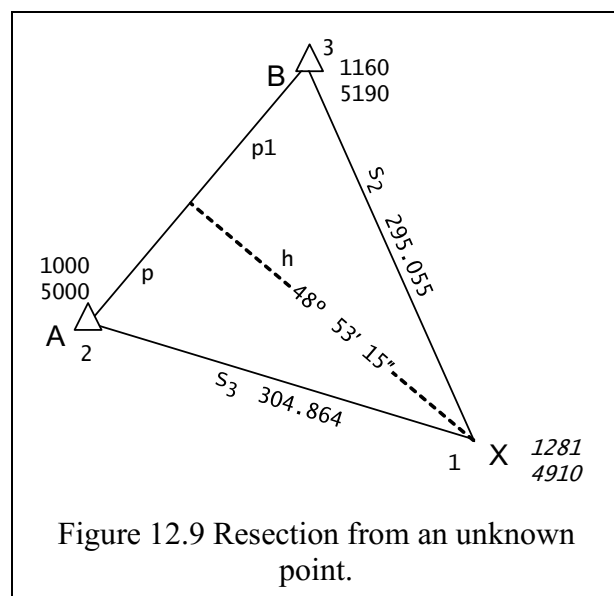

$$N_X = n_X + \delta N_X$$

All surveying equations that involve observations can be reduced to the form:

$$\mathbf{A} \cdot \mathbf{x} = \mathbf{b} + \mathbf{v}$$

\mathbf{x} a vector of the terms to be computed, including coordinates
 \mathbf{b} a vector of the observations
 \mathbf{A} a **matrix** of coefficients (or a design matrix)
 \mathbf{v} a vector of residuals, to be a minimum (or an error vector).

1. Form the \mathbf{x} matrix of the errors in Easting and Northing of the point X:

$$\mathbf{x} = \begin{pmatrix} \delta E_X \\ \delta N_X \end{pmatrix} \text{ is a } 2 \times 1 \text{ matrix.}$$

2. The bearings and distances from the initial coordinates of X to A and B are **calculated**.

$$\theta_{XA} = 287^\circ 45' 34'' \quad s_{XA} = 295.061$$

$$\theta_{XB} = 336^\circ 37' 44'' \quad s_{XA} = 305.026$$

$$\angle AXB = 48^\circ 52' 10'' \text{ (calculated angle, to be used later)}$$

3. Form the \mathbf{A} (3×2) matrix of the observation coefficients for δE and δN .

In general the solution should include the uncertainties of the control points A and B.

However, they are considered **fixed** and so we only consider the uncertainties in the measurements from \mathbf{X} , **vis**;

angle **AXB**

distance **XA**, s_{XA}

distance **XB**, s_{XB}

Fixed points A and B have not appeared in the \mathbf{x} matrix, and thus do not appear in the \mathbf{A} matrix.

From the **calculated** bearings and distances from X to A and B, the angle AXB can be found as the difference between the two calculated bearings.

$$A = \begin{pmatrix} \delta E & \delta N & \delta E & \delta N \\ \cos \theta_{XA} - \frac{\cos \theta_{XB}}{s_{XA} \sin 1''} - \frac{\cos \theta_{XB}}{s_{XB} \sin 1''} & \frac{\sin \theta_{XA}}{s_{XA} \sin 1''} - \frac{\sin \theta_{XB}}{s_{XB} \sin 1''} \\ -\sin \theta_{XA} & -\cos \theta_{XA} \\ -\sin \theta_{XB} & -\sin \theta_{XB} \end{pmatrix} = \begin{pmatrix} -407.5 & 397.5 \\ 0.9523 & -0.3050 \\ 0.3967 & -0.9180 \end{pmatrix}$$

Evaluating A_{11} as an example

note that $\sin 1'' = 0.000004848137 = 1/206265$

$$\begin{aligned} \frac{\cos \theta_{XA}}{s_{XA} \sin 1''} - \frac{\cos \theta_{XB}}{s_{XB} \sin 1''} &= \frac{\cos(287^\circ 45' 34'')}{295.061/206265} - \frac{\cos(336^\circ 37' 44'')}{305.026/206265} = \frac{0.3050}{0.00143} - \frac{0.9179}{0.00148} \\ &= 213.228 - 620.739 \\ &= 407.511. \end{aligned}$$

4. The \mathbf{W} (weight) matrix is a square 3×3 matrix with the weights of the observations on the diagonal. Since they are assumed uncorrelated, the rest of the matrix is filled with zeros.

Form the \mathbf{W} matrix from the standard deviations of the observations. The weight is $1/\sigma^2$:

$$\sigma_\theta = \pm 10'' \quad (\sigma_\theta)^2 = 100 \quad W_\theta = 0.01$$

$$\sigma_s = \pm 0.01\text{m} \quad (\sigma_s)^2 = 0.0001 \quad W_s = 10,000$$

$$\mathbf{W} = \begin{pmatrix} 0.01 & 0 & 0 \\ 0 & 10000 & 0 \\ 0 & 0 & 10000 \end{pmatrix} \begin{array}{l} \text{refers to } \angle AXB \\ \text{refers to } s_{XA} \\ \text{refers to } s_{XB} \end{array}$$

5. Form the **b** matrix (3 x 1); the matrix of the difference between observed and calculated observations. The sense is **obs** – **calc** in the same order as the **v** and **W** matrices. Units are converted to seconds and metres.

$$\begin{array}{l} \text{observed} \quad \angle AXB \quad 48^\circ 53' 15'' \\ \text{calculated} \quad \angle AXB \quad \underline{48^\circ 52' 10''} \\ \text{obs} - \text{calc} = \quad \quad \quad 65'' \end{array}$$

$$\mathbf{b} = \begin{array}{l} \left| \begin{array}{l} 65'' \\ -0.006 \\ -0.162 \end{array} \right| \quad \begin{array}{l} \text{refers to diff } \angle AXB \\ \text{refers to diff } s_{XA} \\ \text{refers to diff } s_{XB} \end{array} \end{array}$$

6. The matrix of unknown, the **x** matrix (3 x 1), results from manipulation of the **A**, **W** and **b** matrices. This discussion is NOT a lesson in matrix manipulation.

$$\hat{\mathbf{x}} = (\mathbf{A}^T \cdot \mathbf{W} \cdot \mathbf{A})^{-1} \cdot (\mathbf{A}^T \cdot \mathbf{W} \cdot \mathbf{b}) \quad (\text{see Awange and Grafarend 2005}).$$

- 6.1 Start by calculating the product $\mathbf{A}^T \cdot \mathbf{W}$ as it is used in both matrices;

$$(2 \times 3) \cdot (3 \times 3) = (2 \times 3)$$

$$\mathbf{A}^T \quad \left| \begin{array}{ccc} -407.5 & 0.9523 & 0.3967 \\ 397.5 & -0.3050 & -0.9180 \end{array} \right| \cdot \mathbf{W} \quad \left| \begin{array}{ccc} 0.01 & 0 & 0 \\ 0 & 10000 & 0 \\ 0 & 0 & 10000 \end{array} \right|$$

$$\mathbf{A}^T \cdot \mathbf{W} \quad \left| \begin{array}{ccc} -4.075 & 9523.5 & 3966.9 \\ 3.975 & -3050.2 & -9197.5 \end{array} \right|$$

- 6.2 Now calculate the product $(\mathbf{A}^T \cdot \mathbf{W}) \cdot \mathbf{A}$;

$$(2 \times 3) \times (3 \times 2) = (2 \times 2)$$

$$\mathbf{A}^T \cdot \mathbf{W} \quad \left| \begin{array}{ccc} -407.5 & 9523.5 & 3966.9 \\ 397.5 & -3050.2 & -9197.5 \end{array} \right| \cdot \mathbf{A} \quad \left| \begin{array}{cc} -407.5 & 397.5 \\ 0.9523 & -0.3050 \\ 0.3967 & -0.9180 \end{array} \right|$$

$$\mathbf{A}^T \cdot \mathbf{W} \cdot \mathbf{A} \quad \left| \begin{array}{cc} 12303.9 & -8166.1 \\ -8166.1 & 10936.8 \end{array} \right|$$

- 6.3 How to calculate the inverse $(\mathbf{A}^T \mathbf{W} \mathbf{A})^{-1}$, a (2 x 2) matrix:

$$\text{Let } (\mathbf{A}^T \mathbf{W} \mathbf{A}) \text{ be called matrix } \mathbf{M} \quad \left| \begin{array}{cc} m_{11} & m_{12} \\ m_{21} & m_{22} \end{array} \right|$$

Calculate inverse of M, in this case using: $\mathbf{M}^{-1} = (1/\det(\mathbf{M})) \times \text{Adjugate}(\mathbf{M})$

The determinant of $\mathbf{M} = (m_{11} \times m_{22} - m_{12} \times m_{21}) = 67879888.83 = 6.788 \cdot 10^7$

The adjugate of $\mathbf{M} = \text{Adj}(\mathbf{M}) = \left| \begin{array}{cc} m_{22} & -m_{12} \\ -m_{21} & m_{11} \end{array} \right| = \left| \begin{array}{cc} 10936.8 & 8166.1 \\ 8166.1 & 12303.9 \end{array} \right|$

Dividing the adjugate matrix by the determinant produces the inverse matrix:

$$\mathbf{M}^{-1} = (\mathbf{A}^T \mathbf{W} \mathbf{A})^{-1} = \text{AdjM}/\det\mathbf{M}$$

$$(\mathbf{A}^T \mathbf{W} \mathbf{A})^{-1} \quad \left| \begin{array}{cc} 1.611^{-4} & 1.203^{-4} \\ 1.203^{-4} & 1.813^{-4} \end{array} \right|$$

- 6.4 To **check** the inverse, we know that $\mathbf{M}^{-1} \times \mathbf{M} = \mathbf{I}$ (the identity matrix)

$$(\mathbf{A}^T \mathbf{W} \mathbf{A})^{-1} \quad \left| \begin{array}{cc} 1.611^{-4} & 1.203^{-4} \\ 1.203^{-4} & 1.813^{-4} \end{array} \right| \cdot (\mathbf{A}^T \mathbf{W} \mathbf{A}) \quad \left| \begin{array}{cc} 12303.9 & -8166.1 \\ -8166.1 & 10936.8 \end{array} \right| = \mathbf{I} \quad \left| \begin{array}{cc} 1 & 0 \\ 0 & 1 \end{array} \right|$$

- 6.5 Now, for the second time, use $(\mathbf{A}^T \mathbf{W})$ to calculate the product $(\mathbf{A}^T \mathbf{W}) \cdot \mathbf{b}$;

$$(2 \times 3) \cdot (3 \times 1) = (2 \times 1)$$

$$\mathbf{A}^T \cdot \mathbf{W} \quad \left| \begin{array}{ccc} -407.5 & 0.9523 & 0.3967 \\ 397.5 & -0.3050 & -0.9180 \end{array} \right| \cdot \mathbf{b} \quad \left| \begin{array}{c} 65.6 \\ -0.006 \\ -0.162 \end{array} \right|$$

$$\mathbf{A}^T \mathbf{W} \mathbf{b} \quad \left| \begin{array}{c} -967.9 \\ 1768.1 \end{array} \right|$$

7. The \mathbf{x} matrix is the product of $(\mathbf{A}^T \mathbf{W} \mathbf{A})^{-1}$ and $(\mathbf{A}^T \mathbf{W} \mathbf{b})$;
 $(2 \times 2) \cdot (2 \times 1) = (2 \times 1)$

$$(\mathbf{A}^T \mathbf{W} \mathbf{A})^{-1} \quad \left| \begin{array}{cc} 1.611^{-4} & 1.203^{-4} \\ 1.203^{-4} & 1.813^{-4} \end{array} \right| \cdot (\mathbf{A}^T \mathbf{W} \mathbf{b}) \quad \left| \begin{array}{c} -967.9 \\ 1768.1 \end{array} \right|$$

$$\mathbf{x} = \quad \left| \begin{array}{c} 0.057 \\ 0.204 \end{array} \right| = \begin{array}{l} \delta E_X \\ \delta N_X \end{array}$$

8. **Adjusted values.** We started by saying that the most likely values of the X coordinates are:

$$E_X = e_X + \delta E_X$$

$$N_X = n_X + \delta N_X$$

- 8.1 From the initial estimated coordinates, add the errors to find the adjusted coordinates:

$$E_X = 1281 + 0.057 = \mathbf{1281.057}$$

$$N_X = 4910 + 0.204 = \mathbf{4910.204}$$

9. The \mathbf{v} matrix of **residuals** is defined by: $\mathbf{v} = \mathbf{Ax} - \mathbf{b}$;

$$(3 \times 2) \cdot (2 \times 1) = (3 \times 1) - (3 \times 1)$$

$$\mathbf{A} \quad \left| \begin{array}{cc} -407.5 & 397.5 \\ 0.9523 & -0.3050 \\ 0.3967 & -0.9180 \end{array} \right| \quad \mathbf{x} \quad \left| \begin{array}{c} 0.057 \\ -0.204 \end{array} \right|$$

$$\mathbf{Ax} \quad \left| \begin{array}{c} 58.0'' \\ -0.0082 \\ -0.1648 \end{array} \right| \quad -\mathbf{b} \quad \left| \begin{array}{c} 65.6'' \\ -0.006 \\ -0.162 \end{array} \right|$$

$$\mathbf{v} = \quad \left| \begin{array}{c} -7.6'' \\ -0.0022 \\ -0.0026 \end{array} \right| \quad \begin{array}{l} \text{residual } \angle \text{AXB} \\ \text{residual XA} \\ \text{residual XB} \end{array}$$

10. Now we must look at the quality of the adjustment by examining the **standard** error of a unit weight. This allows a check against blunders, and also an assessment of whether the weights assigned to adjustment are appropriate.

The **variance** factor σ_0^2 is the sum of the weighted squares of the residuals ($\sum (w_i V_i^2)$) divided by the degrees of freedom ($m - n$)

$$\sigma_0^2 \text{ can also be defined: } \hat{\sigma}_0^2 = \mathbf{v}^T \mathbf{W} \mathbf{v} / (m - n),$$

m = number observations,
 n = number of parameters

$$\mathbf{v}^T \quad \left| \begin{array}{ccc} -7.6 & -0.0022 & -0.0026 \end{array} \right| \cdot \mathbf{W} \quad \left| \begin{array}{ccc} 0.01 & 0 & 0 \\ 0 & 10000 & 0 \\ 0 & 0 & 10000 \end{array} \right|$$

$$\mathbf{v}^T \mathbf{W} \quad \left| \begin{array}{ccc} -0.0758 & -21.76 & -25.57 \end{array} \right|$$

$$\mathbf{v}^T \mathbf{W} \quad \left| \begin{array}{ccc} -0.0758 & -21.76 & -25.57 \end{array} \right| \cdot \mathbf{v} \quad \left| \begin{array}{c} -7.6 \\ -0.0022 \\ -0.0026 \end{array} \right|$$

$$\sigma_0^2 \quad \left| \begin{array}{c} 0.6866 \end{array} \right|$$

Degrees of freedom

m = number observations = 3,

n = number of parameters = 2

$m - n = 1$ degree of freedom

Thus $\sigma_0^2 = 0.6866$ and

$\sigma_0 = 0.83$, which is an acceptable figure for the **standard error**.

11. The variance-covariance matrix is an indication as to whether the various off diagonal elements of the adjustment show any correlation between each other. By examining the upper diagonal of the inverse of the **normal** equation matrix, $(A^TWA)^{-1}$, we can find the **variances** of the parameters **on** the diagonal, and the **covariances** off the diagonal.

$$(A^TWA)^{-1} \begin{vmatrix} \sigma_1^2 & \sigma_{12} \\ \sigma_{21} & \sigma_2^2 \end{vmatrix} = \begin{vmatrix} 1.611^{-4} & 1.203^{-4} \\ 1.203^{-4} & 1.813^{-4} \end{vmatrix}$$

The correlation coefficient between any two parameters can be found from:

$$r_{ij} = \sigma_{ij} / (\sigma_{ii} \sigma_{jj})$$

$$r_{ij} = \begin{vmatrix} \sigma_1 & \sigma_{12} \\ \sigma_2 & \sigma_2 \end{vmatrix} = \begin{vmatrix} 0.013 & 0.704 \\ & 0.013 \end{vmatrix}$$

12. Once the initial coordinates have been adjusted, we have a better estimate of the coordinates. By **iterating**, feeding the adjusted coordinates back in at the start of the exercise, a new set of adjusted coordinates can be found. The iterations continue until the adjustment **converges** so that the “improvement” in coordinates stabilises.

By using $E_X = 1281.057$, $N_X = 4910.204$ as the new estimate for the adjustment produces the following “improved” coordinates:

$E_X = 1281.057$, $N_X = 4910.204$, which shows no change.

This result is to be expected given accurate measurements and a good initial estimate. The other factor is that there is only one degree of freedom, so there is hardly any over-determination.

12.6 Least Squares Solution of an Over-determined Trilateration Problem

Plane coordinates from distance observations is also known as “Intersection by distances.” Ghilani, 5th ed, Section 14.2, p242. Explains the adjustment of an intersection’s coordinates by least squares solution.

Observation of two distances from the unknown control point to **two** known points produces a unique solution to the point’s plane position (see e.g., Awange and Grafarend 2005, Awange and Palancz 2016 for exact solutions).

It only requires two observations, the distances, to produce the two unknowns, the coordinates in E and N.

If more distance observations are made, say to a third known point, then there are three (3) observations for the two unknowns. The system is **over-determined** (i.e., more observations than unknowns).

The third observation (distance), in conjunction with one of the other distances, could be used to check the first answer. In all, we could arrive at three sets of coordinates for the same point using the three combinatorial pairs of observed distances,

- this could be the “easy” way, given the simplicity of the calculations.

By way of example, observations to 3 control points (Figure 12.10) produced the following results:

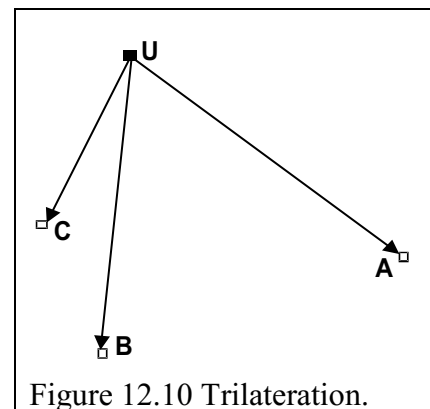

Refer to Section 6.3.2:

Point	Fixed coordinates		Measured horizontal distance, l , from U.
	E	N	
A	1188.113	5333.960	152.420m
B	1069.120	5290.789	138.580m
C	1046.174	5348.466	84.110m

The three sets of coordinates calculated for the unknown point U, using the distance pairs UA, UB; UA, UC and UB, UC are:

U_{AB}		U_{AC}		U_{BC}	
U_{E1}	U_{N1}	U_{E2}	U_{N2}	U_{E3}	U_{N3}
1069.248	5429.369	1069.235	5429.353	1069.178	5429.369

The average of these observations from U is:

U_E	U_N	S_E	S_N
1069.220	5429.364	0.037	0.009

with a standard deviation of:

Is there a better way of doing this, allowing us to find the “most likely” values of the unknown point, U?

Again, we tackle the problem with a least squares solution by using an observation equation of the measurements (observations) to produce an answer that minimises the sum of the squares of residuals.

It is the normal matrix solution that we are after:

$A \cdot x = b + v$, it looks similar and is solved using the same matrix manipulation techniques used previously, but with non-linear functions.

Since we are using **distances** (trilateration) to find the coordinates of U the errors in the distances have to be minimised.

For any line, IJ , there is the observed distance, l_{ij} , plus its associated residual v_{ij} , (see Figure 2.11).

By plane trigonometry it stands that:

$$l_{ij} + v_{ij} = \sqrt{(x_j - x_i)^2 + (y_j - y_i)^2} \tag{12.1}$$

Equation 1.1 is a non-linear function with unknown parameters:

x_i, y_i, x_j, y_j
and the function can be expressed as:

$$F(x_i, y_i, x_j, y_j) = \sqrt{(x_j - x_i)^2 + (y_j - y_i)^2} \tag{12.2}$$

Equation 12.2 can be linearized and solved by a first-order Taylor series expansion by finding the partial derivatives of the elements of the function:

in essence, the final function = initial function + corrections

$$F() = F()_0 + d(F)$$

$$F(x_i, y_i, x_j, y_j) = F(x_{i0}, y_{i0}, x_{j0}, y_{j0}) = \left(\frac{\partial F}{\partial x_i} \right)_0 dx_i + \left(\frac{\partial F}{\partial y_i} \right)_0 dy_i + \left(\frac{\partial F}{\partial x_j} \right)_0 dx_j + \left(\frac{\partial F}{\partial y_j} \right)_0 dy_j \tag{12.3}$$

Thus, for the start coordinates, $i: x_i = x_{i0} + dx_i \quad y_i = y_{i0} + dy_i$
and, for the end coordinates, $j: x_j = x_{j0} + dx_j \quad y_j = y_{j0} + dy_j$ (12.4)

Evaluating the partial derivatives is illustrated using $\partial F / \partial x_i$, using Equation 12.2,

$$F(x_i, y_i, x_j, y_j) = \left[(x_j - x_i)^2 + (y_j - y_i)^2 \right]^{\frac{1}{2}}$$

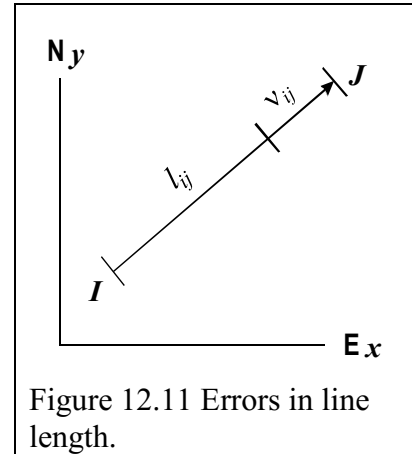

Figure 12.11 Errors in line length.

The partial derivative with respect to x_i is:

$$\left(\frac{\partial F}{\partial x_i}\right) = \frac{1}{2} \left[(x_j - x_i)^2 + (y_j - y_i)^2 \right]^{\frac{1}{2}} \left[2x_j - x_i - 1 \right] \tag{12.5}$$

$$\frac{\partial F}{\partial x_i} = \frac{-2x_j - x_i}{2 \left[(x_j - x_i)^2 + (y_j - y_i)^2 \right]^{\frac{1}{2}}} = \frac{-(x_j - x_i)}{\sqrt{(x_j - x_i)^2 + (y_j - y_i)^2}} = \frac{(x_i - x_j)}{IJ} \tag{12.6}$$

and, similarly, $\frac{\partial F}{\partial y_i} = \frac{(y_i - y_j)}{IJ}$

But $\left(\frac{\partial F}{\partial x_j}\right) = \frac{1}{2} \left[(x_j - x_i)^2 + (y_j - y_i)^2 \right]^{\frac{1}{2}} \left[2(x_j - x_i)(+1) \right]$, rearrange to:

$$= \frac{(x_j - x_i)}{\sqrt{(x_j - x_i)^2 + (y_j - y_i)^2}} \text{ Note the change of subscript order from (12.6)} \tag{12.7}$$

With respect to point x_j and y_j , $\frac{\partial F}{\partial x_j} = \frac{(x_j - x_i)}{IJ}$, and $\frac{\partial F}{\partial y_j} = \frac{(y_j - y_i)}{IJ}$

$$\left(\frac{(x_i - x_j)}{IJ}\right)_0 dx_i + \left(\frac{(y_i - y_j)}{IJ}\right)_0 dy_i + \left(\frac{(x_j - x_i)}{IJ}\right)_0 dx_j + \left(\frac{(y_j - y_i)}{IJ}\right)_0 dy_j = k_l + v_l \tag{12.8}$$

Now the initial parameters are calculated using the approximate (initial) values, $k_l = l_{ij} - IJ_0$ and $IJ_0 = F(x_{i0}, y_{i0}, x_{j0}, y_{j0}) = \sqrt{(x_{j0} - x_{i0})^2 + (y_{j0} - y_{i0})^2}$ (12.9)

First Iteration, i_0 ,

Start with the estimates of $\mathbf{Ax}=\mathbf{b}+\mathbf{v}$. Initial U is $U_{e0} = 1069.220$, $U_{n0} = 5429.364$

In the first iteration, since we have used two measured distances to define approximate coordinates of U, we can say that $k_l = l_{ij} - IJ_0 = 0$ with, in this case, k_l = the difference between the measured and calculated distance to the third (over-determined) point. Point U is determined by distances AU and BU. CU is the over-determined distance.

And because we have turned a non-linear function into a linear function by the Taylor's expansion we can use the normal linear matrix methods for the solution of the least squares adjustment.

$$\mathbf{A} = \begin{array}{c} \left| \begin{array}{cc} x_U - x_A & y_U - y_A \\ AU & AU \end{array} \right| \\ \left| \begin{array}{cc} x_U - x_B & y_U - y_B \\ BU & BU \end{array} \right| \\ \left| \begin{array}{cc} x_U - x_C & y_U - y_C \\ CU & CU \end{array} \right| \end{array} = \begin{array}{c} \left| \begin{array}{cc} 1069.22 - 1188.113 & 5429.364 - 5333.960 \\ 152.42 & 152.42 \end{array} \right| \\ \left| \begin{array}{cc} 1069.22 - 1069.120 & 5429.364 - 5290.783 \\ 138.580 & 138.580 \end{array} \right| \\ \left| \begin{array}{cc} 1069.22 - 1046.174 & 5429.364 - 5348.466 \\ 84.110 & 84.110 \end{array} \right| \end{array} = \begin{array}{c} \left| \begin{array}{cc} -0.78004 & 0.62593 \\ 0.00072 & 0.99996 \\ 0.27400 & 0.96181 \end{array} \right| \end{array}$$

The \mathbf{b} matrix of residual distances. Distances AU and BU calculated position of U, so initial error is 0.000 and $l_{CU} - CU_0$ is (measured - calculated) = - 0.007

$$\mathbf{b} = \left| \begin{array}{c} l_{AU} - AU_0 \\ l_{BU} - BU_0 \\ l_{CU} - CU_0 \end{array} \right| = \left| \begin{array}{c} 154.420 - 154.420 \\ 138.580 - 138.580 \\ 84.110 - 84.117 \end{array} \right| = \left| \begin{array}{c} 0.000 \\ 0.000 \\ -0.007 \end{array} \right|$$

Normalise matrix: $\mathbf{A}^T \mathbf{A} \mathbf{x} = \mathbf{A}^T \mathbf{b}$

Solve for \mathbf{x} $\mathbf{x}_0 = ((\mathbf{A}^T \mathbf{A})^{-1}) \mathbf{A}^T \mathbf{b}$, break the problem down:

$$\mathbf{A}^T \mathbf{A} \left| \begin{array}{cc} 0.6835 & -0.2240 \\ -0.2240 & 2.3168 \end{array} \right| \left((\mathbf{A}^T \mathbf{A})^{-1} \right) \left| \begin{array}{cc} 1.51086 & 0.14607 \\ 0.14607 & 0.44575 \end{array} \right| \mathbf{A}^T \mathbf{b} \left| \begin{array}{c} -0.0019 \\ -0.0067 \end{array} \right| \mathbf{x} = \left| \begin{array}{c} -0.0039 \\ -0.0033 \end{array} \right|$$

At the end of the first iteration the coordinates of U become, as $U_1 = (E_0 + x_{E1}, N_0 + x_{N1})$:

$$1069.220 + (-0.0039) = 1069.2161$$

$$5429.364 + (-0.0033) = 5429.3607$$

Second Iteration, i_1 : Run the second iteration, where now, using the U_1 iterated coordinates as the initial values:

$$A_1 \begin{vmatrix} \frac{1069.2161 - 1188.113}{152.42} & \frac{5429.3607 - 5333.960}{152.42} \\ \frac{5429.3607 - 1069.120}{138.580} & \frac{5429.3607 - 5290.783}{138.580} \\ \frac{5429.3607 - 1046.174}{84.110} & \frac{5429.3607 - 5348.466}{84.110} \end{vmatrix} = \begin{vmatrix} -0.78006 & 0.62591 \\ 0.00069 & 0.99998 \\ 0.27395 & 0.96177 \end{vmatrix}$$

Using the new coordinates for U, the distances AU_1 , BU_1 and CU_1 are calculated (3DP) to create the b matrix:

$$AU_1 = 152.439$$

$$BU_1 = 138.578$$

$$CU_1 = 84.112$$

$$b_1 = \begin{vmatrix} l_{AU} - AU_1 \\ l_{BU} - BU_1 \\ l_{CU} - CU_1 \end{vmatrix} = \begin{vmatrix} 154.420 - 154.439 \\ 138.580 - 138.578 \\ 84.110 - 84.112 \end{vmatrix} = \begin{vmatrix} -0.019 \\ 0.002 \\ -0.002 \end{vmatrix}$$

The normalised matrix: $A^T A x = A^T b$

Is again solved for x $x_1 = ((A^T A)^{-1}) A^T b$, break the problem down:

$$A^T A \begin{vmatrix} 0.6836 & -0.2241 \\ -0.2241 & 2.3167 \end{vmatrix} \begin{vmatrix} 1.51086 & 0.14613 \\ 0.14613 & 0.44575 \end{vmatrix} A^T b \begin{vmatrix} 0.0145 \\ -0.0122 \end{vmatrix} x = \begin{vmatrix} 0.0201 \\ -0.0033 \end{vmatrix}$$

At the end of the second iteration the coordinates of U become, as $U_2 = (E_1 + x_{E2}, N_1 + x_{N2})$:

$$1069.2161 + (0.0201) = 1069.2362$$

$$5429.3607 + (-0.0033) = 5429.3574$$

Third Iteration, i_2 : Run the third iteration, where now, using the U_2 iterated coordinates as the initial values:

$$A_1 \begin{vmatrix} \frac{1069.2362 - 1188.113}{152.42} & \frac{5429.3574 - 5333.960}{152.42} \\ \frac{1069.2362 - 1069.120}{138.580} & \frac{5429.3574 - 5290.783}{138.580} \\ \frac{1069.2362 - 1046.174}{84.110} & \frac{5429.3574 - 5348.466}{84.110} \end{vmatrix} = \begin{vmatrix} -0.77993 & 0.62589 \\ 0.00084 & 0.99996 \\ 0.27419 & 0.96173 \end{vmatrix}$$

Using the new coordinates for U, the distances AU_1 , BU_1 and CU_1 are calculated (3DP) to create the b matrix:

$$AU_1 = 152.422$$

$$BU_1 = 138.574$$

$$CU_1 = 84.115$$

$$b_1 = \begin{vmatrix} l_{AU} - AU_2 \\ l_{BU} - BU_2 \\ l_{CU} - CU_2 \end{vmatrix} = \begin{vmatrix} 154.420 - 154.439 \\ 138.580 - 138.575 \\ 84.110 - 84.112 \end{vmatrix} = \begin{vmatrix} -0.002 \\ 0.006 \\ -0.005 \end{vmatrix}$$

The normalised matrix: $A^T A x = A^T b$

Is again solved for x $x_1 = ((A^T A)^{-1}) A^T b$, break the problem down:

$$\mathbf{A}^T \mathbf{A} \begin{vmatrix} 0.6836 & -0.2236 \\ -0.2236 & 2.3167 \end{vmatrix} \quad ((\mathbf{A}^T \mathbf{A})^{-1}) \begin{vmatrix} 1.51083 & 0.14582 \\ 0.14583 & 0.44573 \end{vmatrix} \quad \mathbf{A}^T \mathbf{b} \begin{vmatrix} -3.5E^{-6} \\ -3.2E^{-6} \end{vmatrix} \quad \mathbf{x} = \begin{vmatrix} -5.7E^{-6} \\ -1.9E^{-6} \end{vmatrix}$$

At the end of the second iteration the coordinates of U become, as $U_2 = (E_1 + x_{E3}, N_1 + x_{N3})$:
 $1069.2162 + (-0.0000) = 1069.2362$ where we can stop, because the distance
 $5429.3574 + (-0.0000) = 5429.3574$ residuals are very small.

Final least squares derived coordinates. The best estimate for U is thus:

$$\mathbf{E}_U \quad \mathbf{1069.236}$$

$$\mathbf{N}_U \quad \mathbf{5429.357}.$$

Calculate the distances from U for residuals from the final coordinates:

Distance residuals, the vs

$$\mathbf{v} = \begin{vmatrix} l_{AU} - AU_F \\ l_{BU} - BU_F \\ l_{CU} - CU_F \end{vmatrix} = \begin{vmatrix} 154.420 - 154.422 \\ 138.580 - 138.568 \\ 84.110 - 84.115 \end{vmatrix} = \begin{vmatrix} -0.002 \\ 0.012 \\ -0.005 \end{vmatrix} \quad \mathbf{v}^2 = \begin{vmatrix} 2.7E^{-6} \\ 1.3E^{-4} \\ 2.2E^{-5} \end{vmatrix}$$

$$\Sigma \mathbf{v}^2 = S_0^2 = 0.00016, \text{ thus } S_0 = \pm 0.013.$$

12.7 Concluding Remarks

This Chapter presented you with skills and techniques that you can employ to transform coordinates from one system to another through the application of the least squares solution. Other efficient techniques for obtaining the transformation parameters include, e.g., the Procrustes method that solves overdetermined systems in closed form (exact solution, see e.g., Awange and Grafarend 2005; Awange and Palancz 2016). In general, with increased use of GNSS for modern civil engineering and mine operations necessitates that the students be equipped with the knowledge and skills to transform such coordinates into local systems.

12.8 References to Chapter 12

1. Awange JL and Palancz B (2016) Geospatial algebraic computations. Theory and applications. 3rd Edition. Springer-Verlag. Berlin, Heidelberg
2. Awange JL and Grafarend EW (2005) Solving algebraic computational problems in geodesy and geoinformatics. The answer to modern challenges. Springer-Verlag. Berlin, Heidelberg.
3. Ghilani, C., Adjustment Computations: Spatial Data Analysis, Wiley, 5th edition.
4. Mackie, J.B, The Elements of Astronomy for Surveyors, 8th edition, 1978, Griffin.
5. <http://www.ga.gov.au/scientific-topics/positioning-navigation/geodesy/geodetic-techniques/calculation-methods>
6. Scofield, W and M. Breach, Engineering Surveying, Elsevier Ltd, Sixth edition, 2007.
7. Uren and Price (2010), Surveying for Engineers, Fourth edition, Palgrave Macmillan.
8. WAIT, Calculus of Observations, 1982.

APPENDICES

Workshop Materials

Scheduled workshops are designed to introduce the aims, methods, techniques and calculations applicable to each field exercise. Part of the workshop will involve a demonstration of the exercise equipment; its care and handling, set-up, reading and recording, and data recording format. Through attendance at the lecture and workshop, and reading the field practical instructions, you should be able to conduct the field exercises with minimum assistance. Practical time is limited, a thorough understanding of the exercise will allow maximum benefit for the group.

A1-1 Workshop 1- Levelling

Aim: To introduce differential spirit levelling as a survey technique. During this workshop, students will get the opportunity to engage with the levelling equipment, understand the tasks below and be able to perform the field exercise also described below. The workshop runs for 2 hours. During the first 1½ hours, the students are introduced to the instruments, levelling procedure and reduction of the measurements using rise and fall method. In the remaining 30 minutes, students go to the field where a demonstration of setting out a level and using it is carried out. The students get hands on experience on how to handle the instrument. Once they have attended the lecture and this workshop, the students should be ready to carry out the field practical 1 in Section A2-2.

Class: Differential levelling, booking readings, inverted staff is negative, rise & fall calculation method. Calculation of RLs. Mention height of collimation method, Establishment of temporary bench marks (TBM) for exercise. Change points, loop closure, checks, acceptable misclose, Collimation error theory, test for collimation error, acceptable error (manufacturer). Best practices; 6 rules of levelling, including balanced sights (especially BS/FS).

Field: Automatic level, unpack, set-up, repacking instrument, tripod stability, Instrument levelling using T method across footscrews, Staff, safety, extension, check joints, verticality, read staff (stadia wires), solid CPs. Booking in the field, equipment record, units of measure (metres), neatness. Concept of Back sight (BS), intermediate sight (IS) and fore sight (FS). Collimation test (two peg test), acceptable errors. Transfer of level via change point (CP). Traverse closure to known bench marks, acceptable errors, open/closed traverse. Field checks of readings. $\Sigma BS - \Sigma FS$, $\Sigma Rise - \Sigma Fall$, $EndRL - StartRL$. Inspect survey area, position of established bench marks (BM), vertical control points.

Method: Set up 6 levels & 4 staffs (one inverted). Each group member read staff 1 (BS) and 2 (FS), establish as CP. Change to another level and read staff 2 (BS), inverted staff (IS) and 3 (FS). Calculate difference in height between all points, check results.

e.g., Figure 13.1. Rise/fall=BS-FS.

$$BS = 1.30, FS = -1.285.$$

$$Rise = 1.3 - (-1.285) = 2.585$$

$$BS = -1.285, FS = 1.30.$$

$$Fall = -1.285 - 1.30 = -2.585$$

Any horizontal line across staves will produce the same result. The structure does not move.

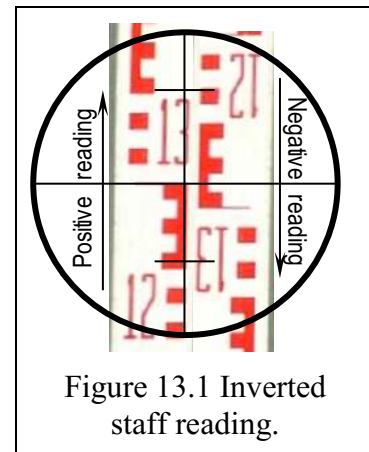

Figure 13.1 Inverted staff reading.

The workshop proceeds in steps as follows:

Step 1: Introduce the students to the levelling equipment below

Step 2: Introduce students to various parts of the Level and the cross-hairs

Step 3: Show the students how to read a staff, Figure 13.2

Step 4: Demonstrate on the board how a two-peg test is undertaken, Figure 13.3.

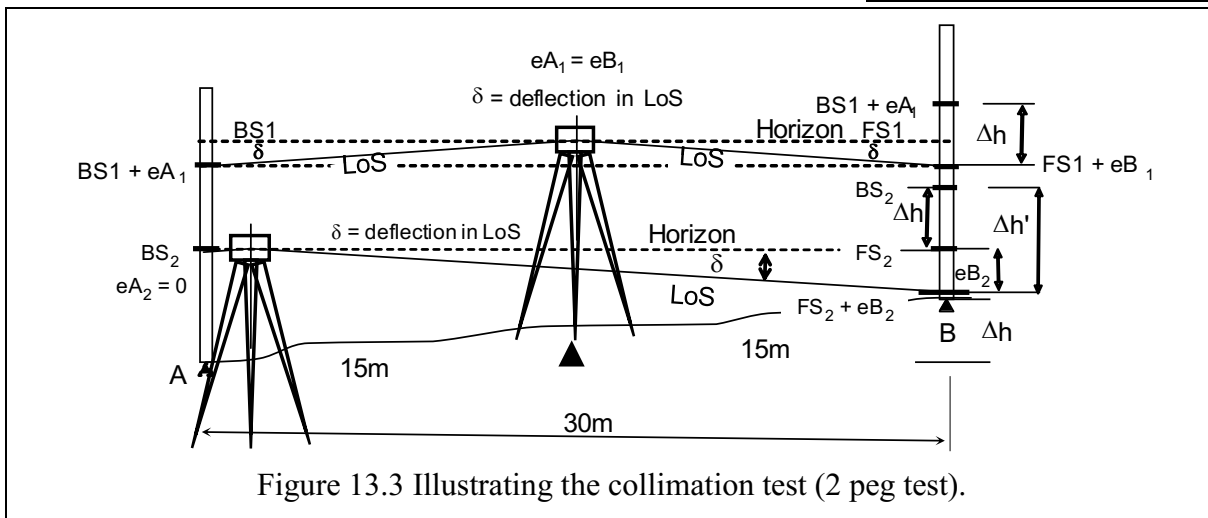
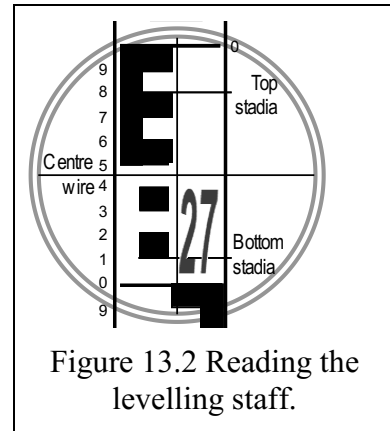

Step 5 Demonstrate the levelling procedure (see Section. 2.5.3) using a level and staff .

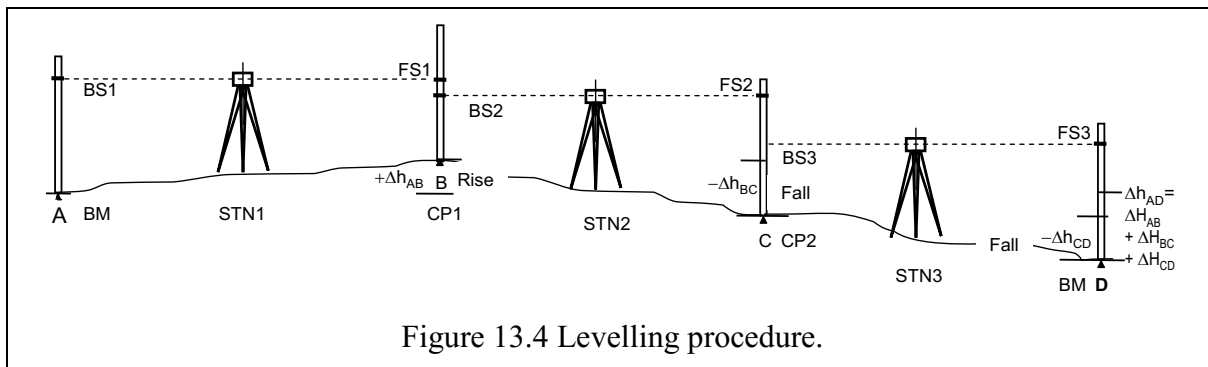

Step 6: Perform a general field reduction example based on rise and fall on the board for the students. After that, let each student perform the following reductions based on rise and fall method. Include the inverted staff (see Figure 13.1). The

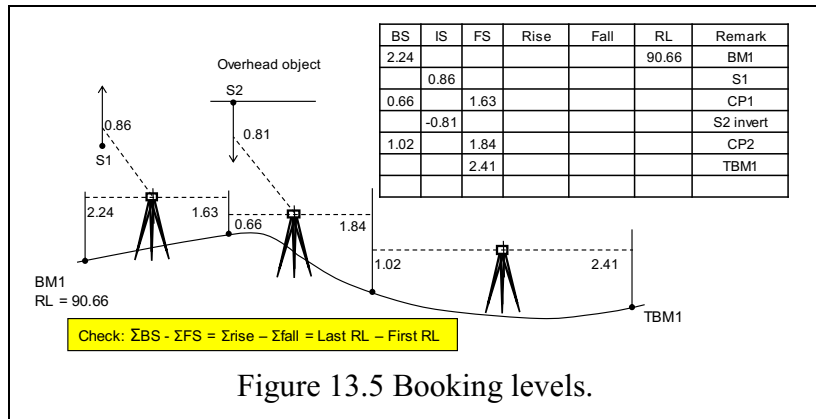

Figure 13.5 Booking levels.

The lecturer can then go around and check the performance of each student and assist where necessary. After all the students have completed, the lecture auto-populates the values on the board based on the students answers. In case of students who are still not to task with rise and fall, the lecturer/tutor should identify them for follow on so as to give them private tutoring. Following this step, the students should proceed to the 30 minutes field demonstration where a tutor has assembled the equipment ready for the demonstration. Students are encouraged to do further readings from books such as Uren and Price (2010).

A1-2 Workshop2 – Earthworks: Relief Representation and Vertical Sections

This workshop aims at enhancing the students understanding of the materials discussed in Chapter 3. The students should therefore consult Chapter 3. The materials can be presented in the manner discussed below.

Aim: Use area levelling to generate a digital terrain model (DTM). Understand specifications of design surface parameters. Extraction and calculation of combined DTM and design surface data. Horizontal and vertical scale. Vertical scale exaggeration. Feature measurement, extraction and plotting. Reporting.

Class: Point positioning methods: random, grid, cross section. Equipment, granularity. Recording observations on field sheets. Feature position measurement techniques; chainage/offset, radiation. Plotting DTM, extraction of vertical height differences. Calculation of survey longitudinal profile and of design surface profile, (longitudinal elevation). Calculation of surface cross sections profile, slope extraction. Extraction of height differences between survey and design profile, discuss design cross section parameters; formation width, batter slope. Calculation batter intercepts, cross section area, from height differences. Calculate longitudinal volume from cross section area, volume by end area versus Simpson's rule. Plot longitudinal terrain and design surface profile to scale. Plot cross sections to scale, Plot plan of area and features to scale. (Trees, pathways, walls, appurtenances.)

Field: Inspect area, define limits. Original BM not accessible. Confirm previously established TBMs. Inspect established longitudinal centre line (CL) control points (CH00, CH93.3) Demonstrate establishment of cross section profile control. Booking in the field, equipment record, units of measure (metres), neatness. Sketch of area. Recording of cross section and profile levels as intermediate sights (IS) Use of CL control points as change points (CP) Field reduction of RLs. Closure of level loop to established TBM, misclose checks. Feature positioning by chainage and offset, recording in FB. Vertical measurement of trees by clinometer and tape. Vertical measurement of trees by clinometer and tape (see Section 2.6.5).

Method: Provide 30 m tapes, clinometers, flagging pins for demonstration.

Discuss team management, division of tasks. Concurrent tasks

A1-3 Workshop 3– Total Station and Angular Measurements

This workshop aims at enhancing the students understanding of the materials discussed in Chapter 4. The students should therefore consult Chapter 4. The materials can be presented in the manner discussed below.

- Aim:** Introduce the students to a Total Station, the instrument used to measure angles and distances. This workshop will also aim at facilitating the understanding of bearings and how they are computed. Units of distances and angles will also be given.
- Class:** Use of Total Stations to measure angles and distances. Recording observations on field sheets. Computing bearings. Field demonstration.
- Field:** Setting out and levelling a Total Station. Measure angles and distances. Establish control and orientation to be used in practical A2-3-1.

The workshop is to be presented in 4 steps as follows:

- Step 1:** Demonstrate to the students in class the Total Station measuring procedure of face left (FL) and face right (FR).
- Step 2:** Discuss with the students the properties of angles, horizontal directions and bearings.
- Step 3:** Introduce the two bearing computation methods (i) deflection angle method and (ii) the back bearing method. Use can be made of a hypothetical triangle before the students are given the examples in the slides below to compute individually. After all the students have completed, the lecture auto-populates the values on the board based on the students answers. In case of students who are still not to task with rise and fall, the lecturer/tutor should identify them for follow on so as to give them private tutoring.
- Step 4:** Once the students have grasped the bearing computation skills, in the remaining half an hour, they should proceed for a field demonstration by the tutor on how to use set up, level and use the Total Station to measure angles and distances.

Workshop slides:

Units of measurement.

Metre, imperial foot, US survey foot, chains & links.

Conversions: 1 foot = 0.3048m, 1m = 3.28084ft = 39.37007874 inches

1chain = 66 feet, 1chain = 100links. 1link = 0.201168m.

1 US survey foot = 1200/3937m (defined, used in some States Plane Coordinate Systems).

Angular measurement.

Circular; (radians), plane; (degrees/grads/mils).

Units of angular measurement.

Degrees, sexagesimal system: 1 circle = 360°, 1°= 60', 1' = 60".

Other units of angular measurement.

Grad/gon, decimal system: 1 circle = 400g, (= 360°),

mils, military system: 1 circle = 6400 mils, 1mil = 3' 22.5", approx. 1/1000 radian.

Units of area measurement.

Metric (metres², hectares), imperial (Acres, ac.; roods, r; perch, p.)

Conversions: 1 are = 100m², 1 Ha = 100are = 10,000m²

10000m² x 0.3048² sq feet = 107,639.104ft²

1 acre = 10sq chains = 66 x 660 ft = 43,560sq ft. = 43560 x 0.3048² = 4046.856m²

1Ha = 107639.104/43560 = 2.471acres (2ac. 1r. 35p.)

Angle calculations:

Forward and back bearings; interior/exterior angles, deflection angles,

addition, subtraction, clockwise positive/ anticlockwise negative.

Bearings and angles, close angles to check bearing.

Coordinate calculations:

Polar to rectangular: Brg (θ), distance (S) to dE, dN,

$$dE = S \sin(\theta), Dn = S \cos(\theta).$$

Rectangular to polar: dE, dN to Brg (θ), distance (S)

$$S = \sqrt{(dE^2 + dN^2)}, \text{ angle} = \text{Atan}(dE/dN), \text{ Brg } (\theta) = \text{angle} + \text{quadrant}.$$

HP10S+, POL(), REC(), functions. (Appendix A5-3)

A1-4 Workshop 4 – Traversing

This workshop aims at enhancing the students understanding of the materials discussed in Chapter 5. The students should therefore consult Chapter 5. The materials can be presented in the manner discussed below.

Aim: Use a Total Station to establish horizontal controls. In this regard, the aim is to develop good observational and computational skills to measure distances and angles in order to establish the easting and northing coordinates of points that are to be used for other engineering tasks.

Class: Point positioning methods: Use of Total Stations to measure angle and distances. Recording observations on field sheets. Balance the angles. Compute the bearings. Perform the Bowditch adjustment to correct for the traverse misclose. Compute the coordinates of given points (stations). Compute the area using coordinates method.

Field: Occupy your station established in practical A2-4. Orient to a given reference. Undertake feature pick up using the Total Station.

The workshop is to be presented in 2 steps as follows:

Step 1: Demonstrate to the students in class the traverse procedure.

Step 2: Let the students independently compute the Bowditch adjustment, Figure 13.7, of the traverse network in Figure 13.6, and the subsequent area using the coordinates method. Note, this workshop builds onto workshop 3; hence the students should be able to compute the bearings. After all the students have completed, the lecture auto-populates the values on the board based on the students answers. In case of students who are still not to task with the Bowditch adjustment, the lecturer/tutor should identify them for follow on so as to give them private tutoring.

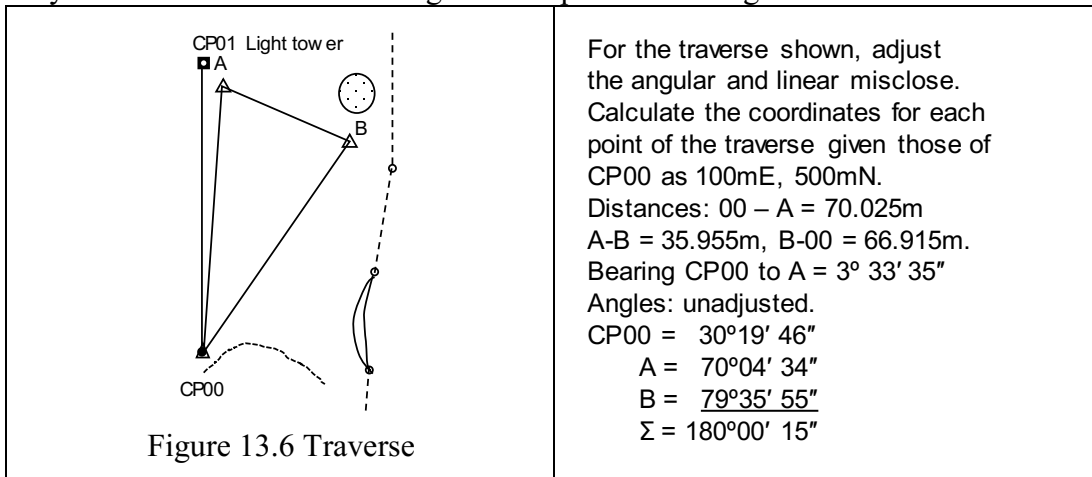

Figure 13.6 Traverse

Line	Forward Bearing	Horizontal Distance	Calculated		Adjustments		Coordinates		
	Adjusted		ΔE	ΔN	δE	δN	E	N	
CP00							100.000	500.000	CP00
00-A	3 33 36	70.025							A
A-B	113 29 06	35.595							B
B-00	213 53 16	66.915							CP00
	Sums								

Figure 13.7 Bowditch adjustment exercise.

Discuss team management, division of tasks. Concurrent tasks

Field Practical Materials

A2-1 Instructions for Field Practical Sessions

All field practical sessions are conducted with a supplied set of “task specifications” which will include a version control. These specifications can change annually and supersede examples contained in this document. Using the correct control version of a document is basic to quality control of a task. The documentation will generally be supplied electronically on your LMS.

A2-1-1 Introductory Remarks

Field practical sessions are designed with staged specific tasks to be undertaken within the overall objectives of the unit.

Objectives The field practical exercises are designed to enable an engineer to undertake surveying tasks applicable to the exploration, measurement, design and layout of points over a project field area. The resultant information will enable the engineer to integrate field data into terrain models developed in Computer Aided Design (CAD) packages.

Learning Outcomes By the end of the semester the successful engineer will be apply basic surveying techniques to:

- position points on a plane surface;
- use modern surveying equipment such as:
 - automatic level, Total Station and GPS;
- carry out team based survey tasks;
- record field data in a specific format;
- perform field reductions and checks of recorded data
- produce field maps and reduce data for CAD systems;
- communicate results to client through written reports.

Workshop sessions are conducted to demonstrate the methodologies, calculations and field equipment to be used in each specific task. It is thus essential to attend the workshops so that the field practical can be undertaken with a full understanding of the task.

A2-1-2 Conduct of Field Practical Sessions.

Within a field practical class students will form groups of 3 (maximum 4) members, and will remain in that group for the duration of the unit.

Each group member is expected to contribute fully to each exercise by participating in the observation, data recording (booking), equipment manipulation (survey assistant), checking and reduction of data. Each group member will be expected to submit an entire report (individual submission) or contribute equally to preparation of a group report.

For each field exercise the group should nominate a leader. The leader has the responsibility of collating and distributing recorded field data in a timely manner so that each member can carry out the required checking, reduction and calculation of field data. For a group submission the leader will be responsible for the submission of the report to the unit supervisor by the due date.

For individual submissions each team member is to ensure they have all the recorded field necessary for preparation of their report, submitted individually by the due date.

Location of Field Exercises and Survey Control.

Within unit outcomes CVEN2000 integrates field surveying and CAD competence. To this end Field Practicals 1 and 2, Area Levelling, and Field Practicals 3 and 4, 3D Surveying and Control, of the survey component will be undertaken in the treed area of the campus between buildings 204 (Engineering) and 105 (Library).

The practical field examination will be conducted on the Edinburg Oval (South).

Survey control is provided by existing bench marks and control points adjacent to the exercise area. Data will be provided for each exercise.

Establishment of control points is a vital task in every job. Additional temporary field control values will be established by each group to either installed points, known to the supervisors, or nominated points as required for the task.

Control and Topographic Survey.

Task 1. Determinations of Vertical Control/Vertical Sections (Field Practical 1 and 2):

Field Practical 1 and 2 will use an automatic level and staff to provide vertical control and ground profile levels. Other topographic data will be measured by use of tapes and clinometer.

Task 2. Determination of Horizontal Control/Digital Terrain Model (Field Practical 3 and 4):

Field Practical 3 and 4 will use a Total Station, prism sets and tapes for the measurement of position and level of control points and topographic features.

Field Examination.

Establishment of Horizontal Curves (Field Practical 5: - Field examination):

The field examination will incorporate survey control and curve chainage points set-out using GPS, curve chainage points set-out using a Total Station. Set-out will be checked using measuring tapes

Optional Assessment (Individual Practical 6: - Assignment):

An optional assessment may be available to students who wish to replace a poorly assessed field practical with a better mark.

The optional assessment will comprise calculation of a determined survey task similar to other field practicals without the need for field work.

A2-1-3 Field Checks

The following checks are to be performed and recorded in the field directly in the field book.

Automatic level and staff

- Two peg (collimation) test,
- Staff systematic error from wear.

Total Station

- Check plate level (bubble),
- Check optical plummet.

Observations for survey control

- Differential levelling check sums and traverse misclose,
- Mean horizontal directions and vertical angles on Total Station (FL/FR),
- Mean slope distances,
- Prism constant.

Observations for topographic pick-up

- Backsight direction applied to Total Station on FL,
- Close of level traverse to established control.

A2-1-4 Computations and Plan Drawings

All computations can be carried out on your HP10s+ calculator. Competency in its use in surveying is essential. The HP10s+ is the only calculator allowed in the final examination.

Appendix A5 has been written for the HP10s+. It is an expansion of the User Guide to incorporate routines appropriate to the computational requirements of the course.

Drawings to nominated scale must be submitted. Neat, inked drawings with title block and scale are expected. Drawing scale is such that they fit on an A4 sheet.

CAD drawings, on A4, may be submitted. They must be to scale and correctly annotated. Calculation by the CAD program must be confirmed by hand calculations.

Computations and drawings will be checked by the supervisors, who will have “model” answers. Submissions will be checked against your field book data.

A2-1-5 Equipment

Exercise field equipment will be issued from the Survey Store (206.150) at the start of the practical period. You should check that you have received all the equipment you signed for. Equipment will be checked on return to the store at the end of the exercise.

Any damage to the equipment, or deficiencies, must be reported to the field supervisor and/or the survey technical officer.

A2-1-6 Hygiene, Safety and Dress

Observer personal hygiene, do not litter in the field.

Personal safety.

At all times you are expected to work in a safe manner, and to respect the safety of others.

Hazards.

Potential equipment hazards, and safe handling procedures, will be part of a briefing.

Be safety aware.

Footwear.

Enclosed footwear is mandatory. Safety footwear is encouraged as it will be needed when you work on an industrial site.

Clothing.

Hats, long sleeved shirts and long trousers are encouraged for sun protections. Sunscreen lotion is available at the Survey Store.

Traffic areas.

The exercise areas are common areas with other members of the University. Exercise care when measuring across pathways and pedestrian access areas.

Be aware of, and give way to, vehicle movements on roadways adjacent the exercise area.

The field task on Edinburgh Oval (South) is kept within the confines of the oval. Apart from crossing Dumas Road, do not survey on the road reserve outside the wooden posts.

A2-1-7 Workshops

Scheduled workshops are designed to introduce the aims, methods, techniques and calculations applicable to each field exercise. Part of the workshop will involve a demonstration of the exercise equipment; its care and handling, set-up, reading and recording, and data recording format.

Through attendance at the lecture and workshop, and reading the field practical instructions, you should be able to conduct the field exercises with minimum assistance. Practical time is limited, a thorough understanding of the exercise will allow maximum benefit for the group.

A2-1-8 Field Practical Instructions

The instructions should be treated as a work order from your senior engineer. The results from your exercises must be treated as the basis for the preparation of a tender document, the awarding of which may impact on your continued employment.

A2-1-9 Field Books and Data Recording

The **original** field book and field sheet observations are the provable records of group work. Each group member must sign the record book for each exercise, (no sign = no mark), task, references and equipment used must be recorded, all observations must be recorded **without** erasure, field drawings neat and legible, errors are ruled out and corrections recorded.

Use a fair copy of the field book with your work. The **original**, as submitted with your reports, is the one evaluated for group marks.

Additional field sheets will be loaded to Blackboard with the exercise field task description and are to be incorporated with the group field book

A2-2 Establishment of Vertical Control and Vertical Sections for a Construction Site

A2-2-1 Field Practical 1: Establishment of Vertical Control

Motivation: In your profession as a civil engineer, dealing with heights of points on topographic surfaces will be a daily routine. Whether you are constructing roads, buildings or in mining, you will need some height information. The term given to these heights with respect to some known Benchmark is Reduced Levels (RL).

Aims (1) **Establishment of vertical control for construction site.**
 (2) **Design a road/drainage to serve a constructed Computer Building.**

Task: **Establish vertical control for construction site.**

Duration: **one practical session of two (2) hours.**

In this exercise, you are required to establish the RLs of CH00, TMB1, TBM2, deck spike D/S134, 705A, CH93.3 (705) and C400 marked on the attached diagram. This type of survey is necessary when, for design work, levels of points are required such that floor levels can be made compatible with new works.

Outcome: Following the lecture, workshop and this practical, you are expected to be able to:

1. Set-up the levelling instrument in a suitable location; stable and convenient height, reticule focussed (eyepiece focus).
2. Observe and record staff readings. Use correct object focussing and removal of parallax against reticule. Make careful interpolation of millimetres between staff graduations.
3. Carry out a levelling exercise.
4. Perform the reductions necessary to obtain RLs from levelling measurements.
5. Perform all the necessary checks pertaining to levelling.
6. Know the possible sources of errors in levelling and how they could be minimized or avoided.

Group: 3-4 students per group.

Equipment:

- 1 automatic level and tripod;
- 1 staff, staff bubble and change plate.
- 2 pegs, hammer.

Field Work:

1. Each group member will be expected to use the level to observe portions of the exercise, and have those observations recorded in the group field book.
2. Start by undertaking a **two-peg** (collimation check) test. This will help you in checking the vertical collimation of the level. Use the provided levelling staves that have been set up for the session.
3. Each group member will make, record and reduce independent observations.
4. Use the rise and fall method of booking.
5. Read the staff carefully. Pay particular attention to focussing and ensure you read the middle wire.
6. Initial open traverse to D/S134. Start the levelling by observing **BM8** (RL 12.418m) as the backsight.
 Proceed with levelling through the points in the following order: BM8, CH00, 2 and 3, then a change point, CP1, to deck spike D/S134.

7. During the initial open traverse check path clearance under access walkway to Building 204. Before leaving your first set-up, take two intermediate shots; one underneath the suspended walkway to building 204, i.e., inverted reading; the other immediately below. This will allow calculation of clearance. Your tutor will show you these points, which you should name 2 and 3.
8. Closed traverse. Restart the levelling by observing **BM8** (RL 12.418m) Proceed with levelling through the points in the following order: BM8, CH00, TBM1, 1, D/S134, TBM2, 705A, CH93.3 (705), C400 and **BM7** (i.e., close the traverse at the second bench mark, BM7 of RL 13.419m). RLs of CH00 and CH93.3 (705) are required for Field Practical 2, Task 1. RLs of deck spike D/S134, 705A and C400 are required for Field Practical 3, Task 2.
9. Enter the observations obtained on the attached booking sheet, **calculate the reduced levels RL using the rises and falls method. Apply all checks.**

Misclosure should be less than ± 0.015 m.

Remember the **six rules of levelling**:

1. Instrument properly levelled, pendulum free; check circular bubble, pendulum “tap”.
2. Backsight distance approximately equal to foresight distance;
3. Instrument, staff and change plate stable. Staff kept on changeplate.
4. Staff vertical; check staff bubble is centred.
5. Remove parallax, **read centre wire**; sharp coincident focus of reticule and object.
6. Close the traverse.

Requirements: On completion of Field Practical 2, area levelling, each person is to submit an individual report including these Field Practical 1 observations:

1. A copy of your group’s field notes
2. Individually **calculated** Height of Collimation test (from the two-peg test),
3. Individually **calculated** RLs of **ALL** points, including checks.
4. Statement of **conformity to required misclosure.**

Note: Field notes will be assessed on the neatness of booking and correctness of recording.

Whereas you may share field notes, the REDUCTIONS and REPORT MUST BE DONE INDIVIDUALLY BY EACH GROUP MEMBER. ANY SORT OF JOINT WORK WILL BE CONSIDERED AS **PLAGIARISM**.

Submission Date: Combined with Practical exercise 2, area levelling, individual submission is required by the commencement of practical 3.

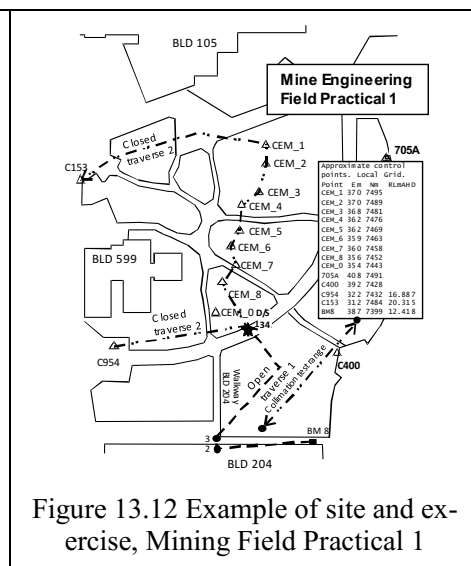
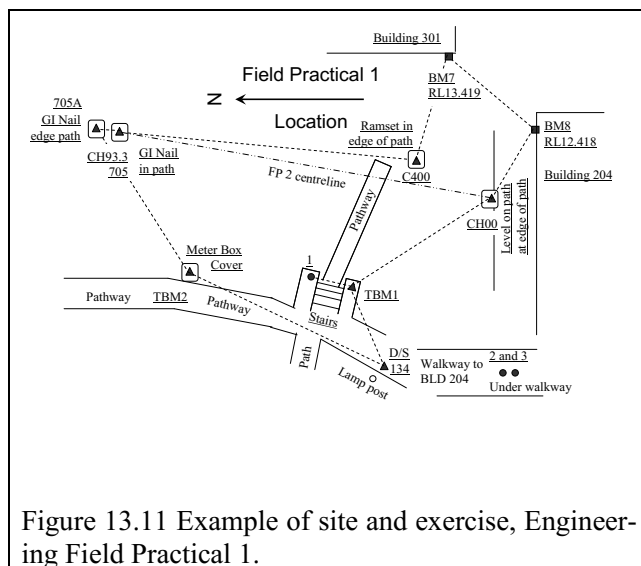

A2-2-2 Field Practical 2: Vertical Sections

Task: Measure area grids to serve a constructed Computer Building or mine site.

Duration: one practical session of two (2) hours.

Undertake levelling of cross sections to support a road/drainage or other design requirements using gridded points to allow preparation of nominated longitudinal and cross sections profiles. Pick up detail of trees and pathways to allow nomination of arboreal and pedestrian disturbance. Calculate volumes, draw plans.

Outcome: Following the lecture, workshop and this practical, you are expected to be able to:

1. Set out a nominated survey grid for section observations.
2. Carry out differential levelling survey over a gridded area.
3. Check levels against control and complete survey to nominated accuracy.
4. Measure the location and height of trees, obstructions and adjacent structures (sumps and paths) within the survey area.
5. Calculate all levels and provide checks.
6. Calculate excavation batters, cross section area and excavation volume to design surface.
7. Draw plans and sections to illustrate report.
8. Present a report on Task 1.

Group: 3 - 4 students per group.

Equipment:

- 1 automatic level and tripod
- 1 metric staff and staff level and 1 change plate
- 1 30m tape
- 1 sets chaining arrows
- 1 optical square, 1 Clinometer

Comments:

1. The vertical control for the exercise will be that which you established during Laboratory 1, at CH00, TBM1, 1, TBM2, and CH93.3 (705), or the various CEM_8 to CEM_1 points.
2. For the **Civil Engineers** this exercise you will be using a 90m section of centre line which will be pegged or otherwise marked at 15m intervals (see Figure 13.13). Temporary bench marks have been established during Task 1 at the 00 chainage (CH00) on the centreline and at the nominal centre line chainage of 93.3m (CH93.3); this point is located outside the work area on the edge of the brick pathway.

3. **Mining Engineers** will produce blast grid RLs for investigation in a GIS package (see Figure 13.14).

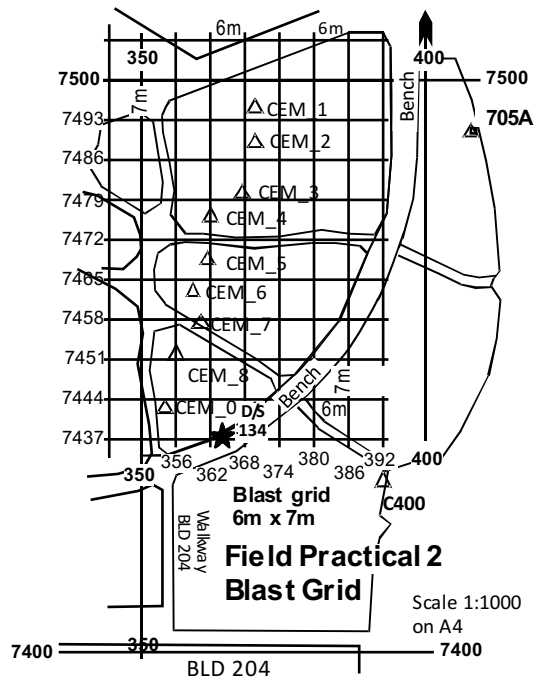

4. Cross section points will be marked at 5m intervals either side of the centre line at each long section 30metre interval. i.e. CH00, CH30, CH60 and CH90.
5. Blast grid intersections will be based on nominated origin coordinates, set out as specified, nominally a 6m x 7m grid.
6. Most required observations will be intermediate sights.
7. See lecture notes on the presentation of the profile and cross-sectional data.

Refer pages 38 – 44 of Irvine & Maclellan, or similar in Uren & Price

Irvine, W and Maclellan, F Surveying for Construction, 5th Edition, McGraw-Hill.

Uren, J and Price, W F (2006) Surveying for Engineers, 4th Edition, Macmillan.

Field Work:

Print your own copies of levelling and pick-up sheets. These must be submitted with the original field book.

1. Centre line pegs will be provided at 15m intervals, or the mine origin will be marked.
2. **Civil:** Share with other groups in marking 5, 10 and 15 metre offsets either side of the centre line to the limit of works on the 00m, 30m, 60m and 90m chainages.

Mining: Share with other groups in marking the 7m offset north grid South from the 7500N origin at 6m intervals from 350E to the limit of works (bench level).

Submission of report.

The report is to be in a format suitable for submission to the supervising engineer.

Group submission of field observations, Field Practicals 1 and 2. (5 marks)

Individual submission addressing the following points: (20 marks)

1. Reduce levels by the Height of Collimation method, applying all checks, including confirmation of group work in Task 1.
2. **Civil:** Plot the longitudinal section using a horizontal scale of 1:400 and a vertical scale of 1:20, including the surface profile and the design pavement.

3. The drainage trench has a **pavement** width of two (2) metres and batters of 1 in 3 which will be suited to unsupported excavation. Assuming a design surface rising grade of **1:40** from a level **-0.50m** (0.50m below) at CH00 towards CH93.3, calculate the grade finish level and the batter intercepts with the natural surface.

Plot cross-sections using a horizontal scale of 1:200 and vertical scale of 1:20. Show this design on each of the four cross-section sketches.

Calculate the area of each cross section. Calculate the volume of excavation using the end area method.

Draw a plan of the area showing the centreline, offset points and levels, trees, pathways and batter intercepts with the natural surface. Plan scale 1:400.

Determine the trees to be removed for the earthworks. Calculate the volume of tree for sale. Determine total volume of saleable timber.

A good copy of the original field notes. This to include the collimation checks and level control traverse from Task 1.

Reduced levels, all plots and a discussion on the reasons for any difference in the centre line levels.

4. **Mining:** Prepare a table of 3D coordinates, E, N and RL, for input to a GIS.

Plot cross-sections using a horizontal scale of 1:500 and vertical scale of 1:20. Draw batters of nominated slope. See Section 3.9.

Calculate the area of each cross section. Calculate the volume of excavation using the end area method.

Draw a plan of the area showing the blast grid and levels, trees, pathways Plan scale 1:500.

A good copy of the original field notes. This to include the collimation checks and level control traverse from Task 1.

Reduced levels, all plots and a discussion on the reasons for any difference in the centre line levels.

DETAIL PICKUP SHEET

Date:.....

Group:.....

Job:.....

<i>Left side features</i>	<i>Chainage</i>	<i>Right side features</i>

Example of a Marking Guide

Name _____ ID _____ Submission date _____

Marking Sheet: Class _____ Group _____ Tutor _____

Task 1. Profile Levelling & Detail Pickup. Individual Mark (/25)

<p>Original Field Notes:</p> <p>Date, Group members, Equipment, S/N Task methods (R/F and checks). Neatness of booking Correctness of recording</p>	<p>5 (group)</p>	<p>FB for practical 1 and 2, level records, pick-up sheet Comment</p>
<p>Submission:</p> <p>1 - Reduction of level sheet to produce control points and profiles. 3mks 2 – Longitudinal plot to correct scale 2mks 3 – Plot cross sections, to correct scale 2mks 4 – Cross section area, volume. 3mks 6 - Plan of area; features, trees, path, batter line, to correct scale 3mks 7 - Tree numbers, selected tree calculations, harvest volume 2mks</p>	<p>15 (individual)</p>	<p>Including results from Field Practical 1. Comment</p>
<p>Presentation:</p> <p>Language, 1mk Complete discussion of the work, misclose, specifications achieved etc 3mks, Visual quality 1mk.</p>	<p>5 (individual)</p>	<p>Report in suitable format to project engineer. Comment</p>

Submission of Practical 1 report. Combined Field Practicals 1 and 2.

The report is to be in a format suitable for submission to the chief engineer including:

Group submission of field observations (Field Book), Field Practicals 1 and 2.

Individual submission addressing the following points:

The submission of a report on the field practical session should present the exercise as a report to your field supervisor. You can thus assume that the supervisor is competent in field surveying. Thus, the report does not need lengthy explanations of methods, procedures and calculation used to determine results.

However, the supervisor will be keenly interested as to whether your task has been accomplished within the required accuracy. Calculations will be checked.

You should start with:

a signed cover sheet describing the task, the dates and the team members:

a short “executive summary” of the results:

- summary of task;
- description of site;
- calculated volumes;
- calculated tree removal;
- accuracy achieved for any level traverse between control points, instrument compliance with task specifications, -were specifications met, and if not, how were they minimised, effect of inaccuracies.
- any site-specific structures likely to hinder or impact on the project.

The report itself should table the following material. You should use and submit the Summary of calculated values to check that you have made the required calculations.

1. Reduced levels calculated by the Rise and Fall method, showing all checks, including confirmation of group work in Field Practical 1.
2. Calculated centreline grade finish levels at each 15m chainage
3. Calculated batter intercepts at each 30m cross section with the natural surface.
4. Calculated area of each cross section.
5. Calculated volume of excavation using the end area method.
6. Plot and label the longitudinal section of the centreline and grade line using a horizontal scale of 1:400 and vertical scale of 1:20.
7. Plot and label the cross-sections using a horizontal scale of 1:200 and vertical scale of 1:20.

Show this design on each of the four cross-sections.

8. Draw and label a 1:400 scale plan of the area showing the centreline, cross section points and levels, trees, pathways and batter intercepts with the natural surface. Show any impediments in the works area that may impact on the task.
9. Determine and indicate the trees to be removed for the earthworks. Calculate the volume of a representative tree for sale. Determine total volume of saleable timber.
10. A good copy of the **original** field book (from group submission). This to include the level collimation (two peg test) checks and level control traverse from Field Practical 1.
11. Reduced levels, all plots, and a discussion on the reasons for any difference in the centre line levels closure.
12. A brief discussion of any problems encountered and methods used to rectify or minimise them.

A short conclusion should précis your exercise results.

Calculation sheets and methods should be included in an appendix.

Task 1. Summary of calculated values, Field Practical 1. Individual Report									
Name:			ID:			Sign:			
Observation date:				Observation Time:					
Class:		Group:		Submission date:					
From FIELD BOOK and calculation, provide the following information. You used the control points BM8 and BM7.									
BM8 RL				BM7 RL				BM7 observed RL	
Collimation test, Error				Level traverse BM8 to BM7. Misclose: Accept/Reject?					
RL CH00:			RL TBM1:			Portal clearance: Pass/Fail?			
RL: Point 1:			RL D/S134:			RL TBM2:			
RL 705 (Ch93.3)			RL 705A:			RL C400:			
Task 1. Summary of calculated values, Field Practical 2. Individual Report									
Observation date:					Observation Time:				
Class:		Group:			Submission date:				
Chain RL	00	15	30	45	60	75	90	93.3	
Surface									
Grade									
C/L h									
W_{left}									
W_{right}									
Area									
Misclose Ch93.3 (Prac1 – Prac2)					Excavation Volume: To grade level.				
Single tree volume:			No trees for removal:				Total volume:		
Submission Check List									
Group original FB Cross sections, profiles?/.			Copies all records/Plan?				Report Due date?		

A2-3 Establishment of Horizontal Control for a Construction Site

A2-3-1 Field Practical 3: Establishment of Horizontal Control

Motivation: In your profession as a civil or mining engineer, dealing with the three dimensional (3D) coordinates of points on topographic surfaces will be a daily routine. Whether you are designing or constructing roads, buildings or in mining, you will need positional information. The term given to these positions with respect to some known plane surface is Coordinates expressed in terms Easting (E (X)), Northing (N (Y)) and height (RL).

- Aims**
- (1) **Establishment of horizontal control for a construction site.**
 - (2) **Generation of a Digital Terrain Model**
 - (3) **Establishment of construction site boundary control.**

Task : **Establishment of horizontal control for construction site.**
Observation and recording of DTM objects.

Duration: **one practical session of two (2) hours.**

In this exercise you will be expected to use a **Total Station** to establish the position a control point by observation to existing control points. This type of survey is necessary when, for design work, control points for building corners points must be established for new works.

Furthermore, you will be expected to locate structures, line features and trees in 3D to enable a digital elevation model (DEM) of the existing site to be constructed in a CAD package.

Outcome: Following the lecture, workshop and this practical, you are expected to be able to:

1. Set-up the Total Station over a given control point.
2. Establish preliminary orientation of the Total Station to true North.
3. Observe and record readings to prisms set up over existing control points.
4. Observe and record readings to a prominent feature to establish site orientation.
5. Carry out a 3D topographic survey of the features of the survey site.
6. Calculate the control point 3D coordinates from the targeted control points.
7. Calculate the orientation correction to be applied to the topographic observations.
8. Calculate the 3D coordinates of the topographic DEM.
9. Perform checks pertaining to angular measurement to control points, the difference between observed and calculated angles.
10. Know the possible sources of errors in Total Station observations and how they could be minimized or avoided.

Group: 3 - 4 students per group.

Equipment:

- 1 Total Station and tripod
- 1 Prism set, prism pole and prism bubble
- 1 Offset tape
- 1 30m tape
- Control points will be occupied by extra 360° prism sets.

Comments:

1. The three-dimension (3D) control points for this exercise will be marked by prism sets established over stations 400 and 705A.
2. **Civil.** Each group will set-up a Total Station over a designated control point in the exercise area. Initial NORTH orientation will be provided by the use of an attached magnetic trough compass oriented to magnetic north. The S end of compass needle bisects lubber lines. A horizontal deviation allows orientation to true north. <http://www.ga.gov.au/oracle/geomag/agrfform.jsp>. From AGRF10, declination, $D = -1.647$ (1 April 2016),

– $1^{\circ} 38' 50''$ at $-32^{\circ} 00' 21''$, $115^{\circ} 53' 40''$. True direction = Magnetic direction + D.
 Magnetic direction = True direction – D, $360^{\circ}M = 358^{\circ} 21' 10''$ True.

Mining. Each group will set-up a Total Station over a designated control point in the exercise area. Orientation will be provided by calculating an approximate grid bearing to 705A from the group's assigned control point. The coordinates are approximate, and those of 705A and C400 will be refined after the completion of the exercise when revised coordinates will be issued.

3. Each group will observe horizontal directions, zenith distance and slope distances to the two control points. Observations to be taken on Face left (FL) and Face right (FR) and slope distance will be recorded at each pointing.
4. After observation of the control points each group will observe: a) a prominent back-sight point for Practical 4 orientation (direction only, FL/FR), b) the North-East corner, and a second point, of Building 204 will be observed to provide location and orientation of the building.
5. After observation of the control points each group will pick up topographic details, pathways, walls, light posts, ground level structures and trees within the survey area. Horizontal directions, zenith distance and slope distances on FL only. Sufficient points will be observed to provide a detailed site and contour plan.

Field Work:

1. Set-up Total Station over the designated control point. Draw station diagrams to allow re-location of the point for Field Practical 4. The group may be given a different station for FP4, using another team's work. Make sure your diagram is complete.
2. **Civil.** Install trough compass and align Total Station to Magnetic North. Set H.ANG on TS screen p2. Key 358.2110 then (ENTER) key. Confirm $358^{\circ} 21' 10''$ alignment on screen. Observe and book a prominent recoverable back sight point. Remove trough compass.
3. **Mining.** Enter your calculated grid bearing from your assigned control point to 705A.
4. Confirm the prism constant (PC) is set to +3 to match the 360° mini-prism targets.
5. From your observation point, measure and record FL and FR directions and slope distances to two selected control points. Bisect the 360° mini-prism.
6. Measure and record height of instrument (HI) and targets (HT). Sketch and measure location of control points.
7. Observe a prominent point (edge BLD105) by direction only, FL/FR, for use as back-sight orientation for FP4.
8. After completing control station observations, check that TS is on FL, place the prism on the prism pole and adjust the prism HT to match the TS HI. Change the prism constant (PC) to -30.
9. Observe the NE corner of building 204 to provide a datum for the position of the proposed building, pick another point on the north face of 204 to provide orientation.
10. Commence the topographic survey; reading and recording FL direction, VA and slope distance to each chosen topographic point. Use a feature codes for points. Referring to the sketch plan, pick up sufficient feature points to complete a topographic plan of pathways, trees, light poles and service points within the works area. Obscured points may have to be recorded to an offset point to provide location. Pick up two points used in Field Practical 1 to provide integration of the area levelling into your DEM. (Include deck spike D/S134). Pick up corners of building site for calculation of RLs to be incorporated in design. Measure distances from corner points on brick paving.

Field Data Reduction:

1. Reduce field observation to control points. Use mean FL/FR zenith angle and mean slope distances to calculate horizontal and vertical distances to the control points. Use mean FL/FR directions to determine directions to control points.
2. Calculate horizontal coordinates of your control point using the calculated horizontal distances by the method of “intersection by distances”.
3. Calculate the RL of your control point using the vertical distance from the instrument to the one prism, and allow for HI and HT. Check your control RL by calculating the to the second prism set. Check RL of the established control points against RLs determined in Field Practical 1.
4. Check the mean angle from the instrument to the two control points against the angle calculated by the Cosine rule from three (3) distances.
5. Calculate the bearings to your two control points. Determine the rotation angle to be applied to one of your mean directions to align your DEM observations.
6. Apply the rotation angle to your DEM observations. Calculate the horizontal and vertical distances from the VA and the slope distance. Distances to trees should be adjusted by an estimate of diameter. Calculate the rectangular (dE, dN) coordinates to each DEM point from your station. Calculate E and N coordinates of each DEM point for your site plan. Calculate RL for each DEM point from the vertical distance (dH) from your station.
7. Calculate the orientation of your Backsight (BLD105). This value will be used in FP4.
8. Calculate the corner and face coordinates (E, N) of building 204 to use as a datum for your Civil Computer Lab location. Offset distances will be advised.
9. **You may have to swap data with another group in FP4. Ensure it is complete.**

Location of works

Control point coordinates: PCG94,
AHD

C954

PCG94 Modified for CVEN2000

E: 57322.099m **322.099**

N: 257432.392m **7432.392**

AHD: 16.887m

~~C956~~

~~PCG94 Modified for CVEN2000~~

~~E: 57417.584m **417.584**~~

~~N: 257402.710m **7402.710**~~

~~AHD: 12.650m~~

705A

PCG94 Modified for CVEN2000

E: 57407.808m **407.810**

N: 257491.205 **7491.198**

AHD: As determined during FP1

C400

PCG94 Modified for CVEN2000

E: 57392.107m **392.107**

N: 257428.494m **7428.494**

AHD: As determined during FP1

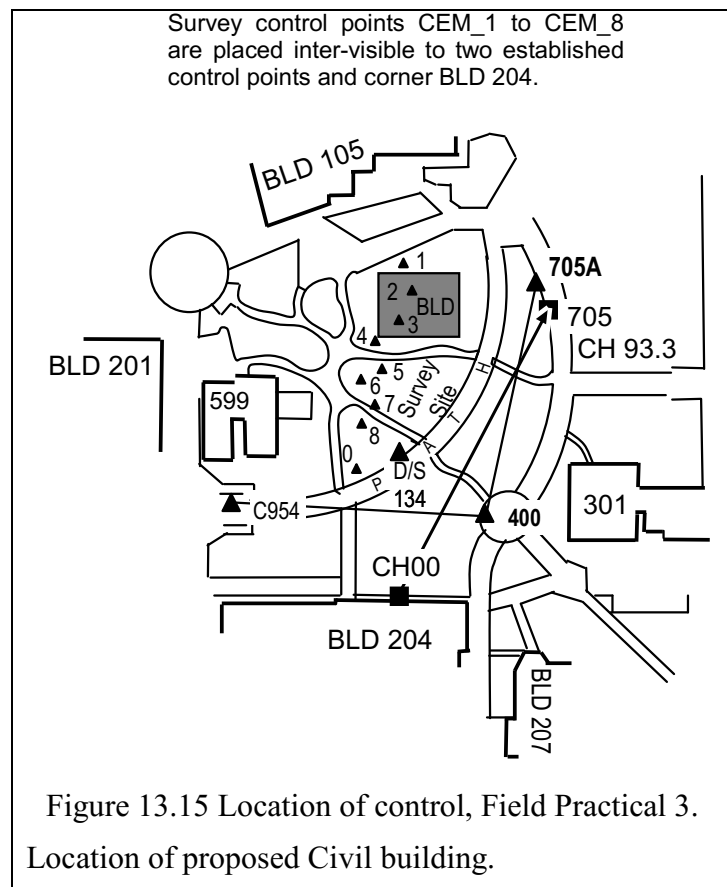

A2-3-2 Field Practical 4: Establishment and Adjustment of Construction Site Boundary Control

Task: Establishment and adjustment of construction site boundary control.

Duration: one practical session of two (2) hours.

In this exercise you will be expected to use a **Total Station** to fully observe a horizontal triangular control network and adjust the coordinates of the network using the Bowditch adjustment. This type of survey is necessary when, for design work, control points for building corners points must be established for new works.

Your group may be allocated a different control station from the one observed in FP3. You may have to swap your field results with another group.

Outcome: Following the lecture, workshop and this practical, you are expected to be able to:

1. Set-up the Total Station over an established control point.
2. Establish preliminary orientation of the Total Station using established back sights (BS).
3. Position two (2) extra control points adjacent the proposed computer building.
4. Sequentially observe and record readings to prisms set up over the 3 control points.
5. Calculate and adjust the 3 internal observed angles and calculate the adjusted bearings.
6. Calculate the point 3D coordinates from the established control point by traverse.
7. Calculate the misclosure of the traverse.
8. Adjust the traverses coordinates using the Bowditch adjustment.
9. Know the possible sources of errors in Total Station observations and how they could be minimized or avoided.

Group: 3 - 4 students per group.

Equipment:

- 1 Total Station and tripod
- 2 Prism sets and tripods, PC -30.
- 1 Offset tape
- 1 30m tape
- 3 pegs and hammer, flagging.

Comments:

1. The backsight from the previously established control point (Task 1) will be used to provide orientation for the exercise.
2. Two other inter-visible control points will be established near the proposed computer building to provide set-out control.
3. By traverse each group will observe horizontal directions, zenith distance and slope distances at the three control points. Observations to be taken on Face left (FL) and Face right (FR) and slope distance will be recorded at each pointing.
4. A full calculation of the coordinates of the traverse will be made using the Bowditch adjustment.
5. A report will be made of the results.

Field Work:

1. Set-up Total Station over the previously established control point. Record instrument height, HI. Ensure the PC -30 is set in the Total Station.
2. On FL, observe the Backsight established in Field Practical 3 and enter the calculated bearing to the Total Station. This is the orientation of the traverse network.
3. Establish the two other building control points, A and B, set-up prism sets over the points. Record the target heights, HT A and HT B.
4. After setting the back bearing on Face Left (FL), record the horizontal distance and direction to both points A and B of your triangle. Repeat these measurements on Face

- Right (FR). Use an appropriate booking table (Field notes). Directions are read in sequence FL A – FL B – FR B – FR A. Slope distance is read at each pointing.
5. Swap the prism on A to the initial CP and move your Total Station to point A on the triangle. **DO NOT** remove the instrument tribrachs from the tripod, use the tribrach lock to release the instruments. Ensure that they lock securely in the new position. Read the direction and distance of A-CP, read the direction and distance of line A-B. Now swap the Total Station and the prism between A and B, read a direction and distance B-A and then read the direction and distance of line B-CP.
 6. Use the mean FL/FR BRG initial CP to A as the fixed orientation of your control adjustment.
 - (i) Calculate your angular misclose. Adjust angles, calculate adjusted bearings of sides.
 - (ii) Calculate the linear misclose from adjusted(see appropriate lecture).
 - (iii) Find the coordinates for the two unknown corners of the triangle A and B using Bowditch adjustment.
 - (iv) Plot the control points as well as the detail pickup features. Scale 1:500
 7. Calculate the plane area of the triangle using the coordinate method.

Submission of report.

The report is to be in a format suitable for submission to the chief engineer.

Group submission of field observations, Field Practicals 3 and 4. (5 marks)

Group submission addressing the following points: (20 marks)

1. Calculation of established control point in Practical 3.
2. Back bearings to control points. Rotation angle for orientation of DEM pickup.
3. 3D coordinates of all DEM points. Coordinates of NE corner building 204.
4. Report on Bowditch adjustment of control points A and B. Angular adjustment of traverse angles. Adopted bearings of traverse. Linear misclose. Final 3D coordinates. Area of triangle.
5. A good copy of the original field notes. This is to include the station diagrams, checks and control traverse from Task 1. (FP1)
6. **Original field book of FP3 and FP4.** This is the document used to check your work.

Example of Marking Guide

Tutor _____ Class _____ Group _____ ID _____
 Submission date: _____ ID _____
 ID _____
 ID _____

Task 2. Marking Sheet:

Survey Control, DEM and Setout for a Construction Site. _____ Group Mark (/25)

<p>Field Notes: Date, Group members, Equipment, Make, model, S/N Task methods (L/R face, S dist, L face for pickup). Neatness of booking Correctness of recording</p>	<p>5 (group)</p>	<p>Good copy of Field Book, Total Station records, feature pick-up sheet Comments:</p>
<p>Submission: 1 – Calculation of control points established in Practical 3. 3 mks 2 – Back bearings to control points. Rotation angle for orientation of DEM pickup. 1 mk 3 – 3D coordinates of DEM points. Coords of NE corner BLD 204 3 mk 4 – Report on Bowditch adjustment of control points A and B. 3 mks 6 – Adjusted coordinates by Bowditch. 3 mks 7 – Misclose ratio. 1 mk 8 – Area calculation. 1 mk 9 – Plot of control points, DEM points to suitable scale. Point list for CAD export. 2 mks 10 – Brg/dist/RL building and site corners 3 mks</p>	<p>20 (group)</p>	<p>Comments:</p>

Submission of report. Combined Field Practicals 3 and 4.

The report is to be in a format suitable for submission to the chief engineer including:

Group submission of field observations, Field Practicals 3 and 4.

Group submission addressing the following points:

The submission of a report on the field practical session should present the exercise as a report to your field supervisor. You can thus assume that the supervisor is competent in field surveying. Thus, the report does not need lengthy explanations of methods, procedures and calculation used to determine results.

However, the supervisor will be keenly interested as to whether your task has been accomplished within the required accuracy of the task.

You should start with:

a signed cover sheet describing the task, the dates and the team members:

a short “executive summary” of the results:

- summary of task;
- description of site;
- calculated initial control point and orientation;
- calculated coordinates of CAD design datum;
- accuracy achieved for traverse between building set-out control points, instrument compliance with task specifications, were specifications met, and if not, how were they minimised, effect of inaccuracies.
- any site-specific structures likely to hinder or impact on the project.

The report itself should table:

1. Three dimensional (3D) coordinates of initial control point calculated by the “Intersection by Distances” method from two established control points, showing all checks, including confirmation of group work in Field Practical 3.
2. Calculated orientation to one of the two control points.
3. Calculated 2D coordinates of the north-east corner of building 204.
4. Calculated 3D coordinates of all points used to create the site digital elevation model (DEM). The format to be suitable for input to the AutoCAD Revit BIM program.
5. Adjusted coordinates of the building control points established in Field Practical 4. Include statement of traverse closure adjustment, coordinate misclosure and traverse accuracy using the Bowditch adjustment procedure. Calculated area of enclosed triangle using the coordinate cross multiplication method.
6. Draw and label a plan of the area showing the all control points used or established, DEM points and feature code. Show any impediments in the works area that may impact on the building location.
7. Show a tie to the centreline of the path design (Field Practical 2) including the design finish level at CH90.
8. The original field book and a good copy of the original field notes.
9. A brief discussion of any problems encountered and methods used to rectify or minimise them.

A short conclusion should précis your exercise results.

Calculation sheets and methods should be included in an appendix.

Task 2. Summary of calculated values, Field Practical 3				
Observation date:		Observation Time:		
Class:		Group:		
Student ID		Signature		
Student ID		Signature		
Student ID		Signature		
Student ID		Signature		
From FIELD BOOK and calculation, provide the following information You will have occupied one of control points CEM_1 to CEM_8. You used CPs C400 and 705A.				
Name CP 1: _____ HI		Name CPs used: 2: _____, 3: _____		
Coordinates 2:	E:	N:	RL:	HT:
Coordinates 3:	E:	N:	RL:	HT:
Mean Horizontal distance H3: 1 to 2:				
Mean Horizontal distance H2: 1 to 3:				
Mean direction 1 to 2				
Mean direction 1 to 3				
Mean angle at 1				
Mean direction 1 to Back Sight				
Mean direction 1 to CNR 204		H Dist		
Resulting calculated coordinates of Control Point 1, orientation correction and BS BRG				
Calculated coords 1:	E:	N:	RL:	
Calculated Orientation, 1 to 2				
Orientation rotation angle				
Adopted BRG 1 to Back Sight				
Adopted BRG 1 to CNR 204		Coords CNR 204	E	N
SE corner Design building	E	N		
RLs of site corners:	NW	NE	SE	SW
RL D/S 134 (FP1):	RL D/S134 (FP3):	Misclose: _____		

Task 2. Summary of calculated values, Field Practical 4 and Bowditch adjustment			
Observation date:		Observation Time:	
Class:		Group:	
Student ID		Signature	
Student ID		Signature	
Student ID		Signature	
Student ID		Signature	
Initial Mean Bearing CP00 - A			
Unadjusted angle CP00			
Unadjusted angle A			
Unadjusted angle B			
Angular Misclose		Correction per angle	
Adjusted angle CP00			
Adjusted angle A			
Adjusted angle B			
Adjusted BRG CP00 - A			
Adjusted BRG A - B			
Adjusted BRG B - CP00			
Misclose d_E		Misclose d_N	
Linear Misclose		Misclose ratio 1:	
Adjusted E_{CP00}		Adjusted N_{CP00}	
Adjusted E_A		Adjusted N_A	
Adjusted E_B		Adjusted N_B	
Adjusted E_{CP00}		Adjusted N_{CP00}	
Area CP00-A-B-CP00; m^2			
BRG/H Dist from CP_A to SE corner building		BRG	H Dist
BRG/H Dist from CP_B to SE corner building		BRG	H Dist

A2-4 Establishment of Horizontal Curves Field Examination

A2-4-1 Calculation and Set-out of a Simple Curve—Assessed Field Practical 5

Group work component: To be assessed in the field

Individual component:

Calculations and drawing of a nominated curve to be submitted at the field practical session.

Objective:

Individually: to calculate a nominated curve, posted to Blackboard, and draw all elements at a scale of 1:1000. (Fits on A4)

Group component, assessed in field examination:

As a group, work together to set out a nominated simple circular curve, check set-out, report misclosures, compare TS coordinates with handheld GPA. Check GPS accuracy against a known control point. Evaluate misclose.

Objective:

As a group: Set out a simple circular curve by deflection and chord measurement method. The curve has been pre-calculated prior to the practical session and is to be set out by each group in the field. The group will then check the curve for set-out precision.

The practical will be conducted on the Edinburgh Oval South opposite the John Curtin Centre.

Group: 4 students per group.

Equipment:

- 1 Sokkia SET530 Total Station and tripod, peanut prism.
- 50m tape, 8m offset tape, 1 set chaining arrows, 2 pegs, 1 hammer, flagging
- Hand-held Garmin 76/72H GPS.

Comments:

1. For the individual portion, each group will be given data describing a simple circular curve. The curve describes a circular path having a centreline, left and right pavement offsets and offsets to back of kerb. Each member of the group will calculate a designated offset.

The curves will be about 25m radius, deflection $< 90^\circ$ and have 5 or 6 chainage points.

2. All elements of the group field curve have been pre-calculated ready for field set-out.
3. In the field your tutor will provide one of the pre-calculated curve designs and you will lay that design out by deflection angle and chord measurement.
4. On completion of the set-out you will be required to evaluate the set-out using a hand-held GPS.
5. Suggested reading:

Uren, J and Price, W F (2006/2010), Chapter 12, Circular curves, setting out by traditional methods.

Irvine and Maclennan, 5th Edition, definitions and formula used in workshop:

Field Work: (See Figure 13.16).

1. A position for each group's tangent point (TP1) using the handheld GPS will be indicated on a diagram of the area (Field sheet A2-4-2, Figure 13.18). Peg TP1 at that position using the MGA coordinates from the GPS. (Field sheet A2-4-4).
2. Peg the centre point, O, using the GPS. DO NOT USE THE TAPE OR PRISM.
3. Set the Total Station over the TP1, sight on centre, O, on Face RIGHT and set 0° using the F3 button [0.SET]. Plunge telescope on to face LEFT so that the TS is pointing to 360° .
4. Turn the TS to 90° and peg the intersect point (IP) at the **calculated** tangent distance using the provided prism. DO NOT USE THE TAPE.

5. You will then peg TP2 at the appropriate bearing using the 50m tape, noting it's through chainage. DO NOT USE THE PRISM.
6. Share within your group the task of pegging the centreline with flagged chaining arrows at the required chainages, using the traditional deflection angle and chord measurement method (Field sheet A2-4-3). The curve is small enough to allow the chord to be measured with a 50m cloth tape from the setup TP.
7. Measuring from your GPS centre peg, confirm the curve radius to each chaining arrow using the tape. Other group members will confirm the individual chord distances **between** each chaining arrow, Figure 13.17. Record the measurements (Field sheet A2-4-5).
8. Concurrent with task 7 above, locate each chaining arrow by using the hand-held GPS. Read and record the MGA coordinates (A2-4-5).
9. In the field, calculate the difference in coordinates between the design MGA coordinates of the chaining arrows and the MGA coordinates observed with the GPS. Calculate the misclose distance between the design and the set-out chainage points.
10. Hold the hand-held GPS at Pillar 18 (neat the WAIT logo) and record the coordinates every 10 seconds for a minute. Compare the mean records with the given coordinates of Pillar 18 (Field sheet A2-4-5).

Marking guide: Complete data on example field practical instruction guide, A4-5.

Marks for this practical will be awarded for your field work completed during the practical session and for individual calculations done before reporting to the field (see your individual component on the Blackboard). It is most important that the group plans how to proceed with the task. **Fill in details of group members on assessment form as soon as you set up. (Field sheet A2-4-6).**

Be familiar with the set-up and centring of the Total Station, the orientation and setting of the zero [0 SET] direction function, reading the HAR and H-A distance. Fix "Out of range" error.

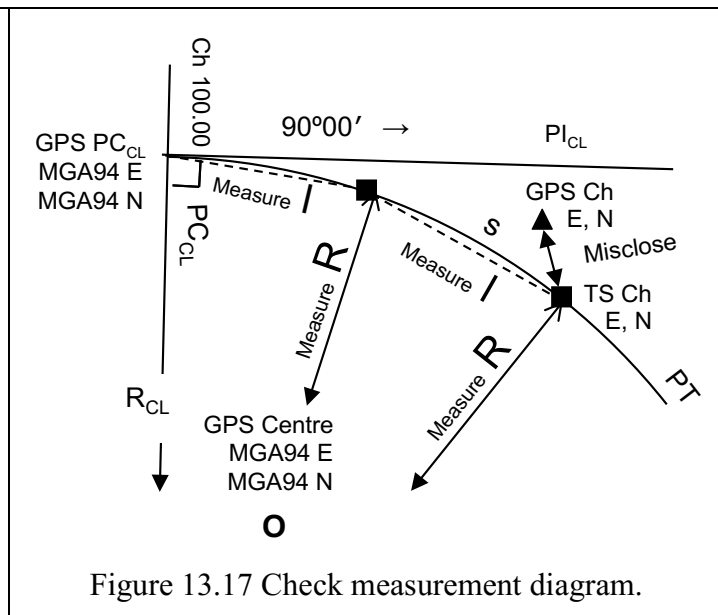
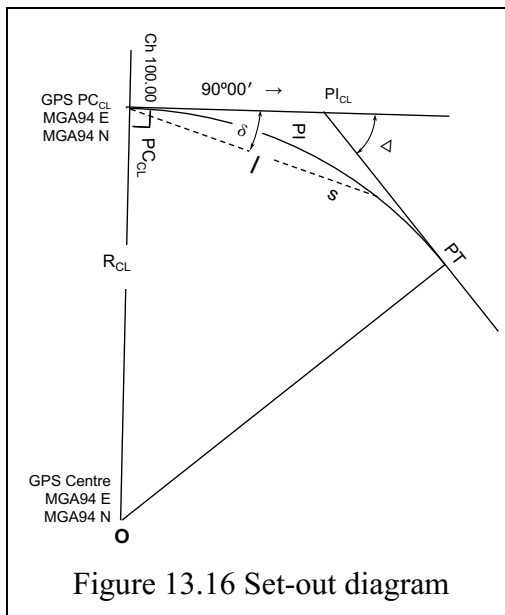

A2-4-2 Location of Field Work: Edinburgh Oval South

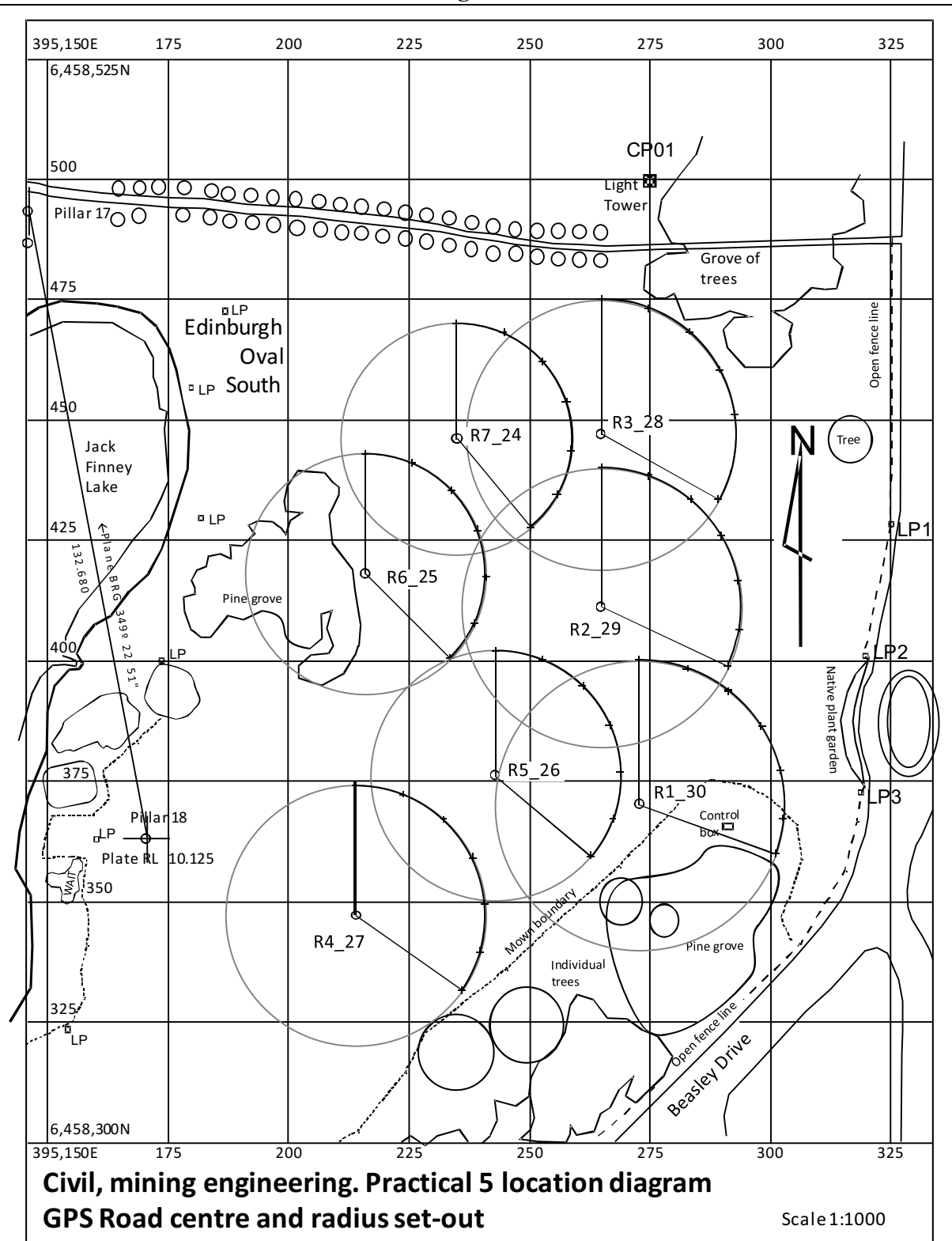

Figure 13.18 Location Field Practical 5

A2-4-3 Curve Set-out Data

LIST OF BEARINGS and CHORD DISTANCES – FOR EACH GROUP

Road centre lines bearings and chord distances on Edinburgh Oval South: **$\Delta = 110^\circ$ Road 1 (Group 1) R = 30m**

Point	Bearing	Chord
Centre	180° 00' 00"	30.000
PC 100	90° 00' 00"	0.000
CH 110	99° 32' 57"	9.954
CH 120	109° 05' 54"	19.632
CH 130	118° 38' 52"	28.766
CH 140	128° 11' 49"	37.102
CH 150	137° 44' 47"	44.411
PT 157.60	145° 00' 00"	49.149

 $\Delta = 114^\circ$ Road 2 (Group 2) R = 29m

Point	Bearing	Chord
Centre	180° 00' 00"	29.000
PC 100	90° 00' 00"	0.000
CH 110	99° 52' 42"	9.951
CH 120	109° 45' 25"	19.606
CH 130	119° 38' 08"	28.680
CH 140	129° 30' 51"	36.904
CH 150	139° 23' 34"	44.033
PT	147° 00' 00"	48.643

 $\Delta = 119^\circ$ Road 3 (Group 3) R = 28m

Point	Bearing	Chord
Centre	180° 00' 00"	28.000
PC 100	90° 00' 00"	0.000
CH 110	100° 13' 53"	9.947
CH 120	110° 27' 46"	19.578
CH 130	120° 41' 39"	28.586
CH 140	130° 55' 32"	36.684
CH 150	141° 09' 25"	43.617
PT 158.15	149° 30' 00"	48.251

 $\Delta = 125^\circ$ Road 4 (Group 4) R = 27m

Point	Bearing	Chord
Centre	180° 00' 00"	27.000
PC 100	90° 00' 00"	0.000
CH 110	100° 36' 37"	9.943
CH 120	111° 13' 14"	19.546
CH 130	121° 49' 51"	28.480
CH 140	132° 26' 28"	36.441
CH 150	143° 03' 05"	43.156
PT	152° 30' 00"	47.899

 $\Delta = 130^\circ$ Road 5 (Group 5) R = 26m **$\Delta =$ Road 5 (Group 5) R =**

Point	Bearing	Chord
Centre	180° 00' 00"	26.000
PC 100	90° 00' 00"	0.000
CH 110	101° 01' 06"	9.938
CH 120	112° 02' 12"	19.511
CH 130	123° 03' 18"	28.363
CH 140	134° 04' 25"	36.170
CH 150	145° 05' 31"	42.644
PT 158.99	155° 00' 00"	47.128

 $\Delta = 135^\circ$ Road 6 (Group 6) R = 25m **$\Delta =$ Road 6 (Group 6) R =**

Point	Bearing	Chord
Centre	180° 00' 00"	25.000
PC 100	90° 00' 00"	0.000
CH 110	101° 27' 32"	9.933
CH 120	112° 55' 05"	19.471
CH 130	124° 22' 38"	28.232
CH 140	135° 50' 11"	35.868
CH 150	147° 17' 44"	42.074
PT	157° 30' 00"	46.194

 $\Delta = 140^\circ$ Road 7 (Group 7) R = 24m

Point	Bearing	Chord
Centre	180° 00' 00"	24.000
PC 100	90° 00' 00"	0.000
CH 110	101° 56' 11"	9.928
CH 120	113° 52' 23"	19.425
CH 130	125° 48' 35"	28.085
CH 140	137° 44' 47"	35.528
CH 150	149° 40' 59"	41.436
PT 158.64	160° 00' 00"	45.105

Set-out instructions

1. Set the PC and centre point by **GPS**.
2. Calculate TD and set IP with **prism**
3. Set the chainage points out using the Total Station for bearing and the 50m tape for chord distance.
4. Calculate in chord, through chord and out chord distances for checks between chainages.

A2-4-4 Curve Coordinate Data for Each Group

Coordinates are Map Grid of Australia (MGA94), Zone 50.

Road centre lines on Edinburgh Oval South. Set only PC and Centre with GPS.**Road 1 (Group 1) R = 30m, $\Delta = 110^\circ$**

Point	Easting	Northing
Centre	395,273.0	6,458,370.0
PC 100	395,273.0	6,458,400.0
CH 110	395,282.8	6,458,398.3
CH 120	395,291.6	6,458,393.6
CH 130	395,298.2	6,458,386.2
CH 140	395,302.2	6,458,377.1
CH 150	395,302.9	6,458,367.1
PT 157.60	395,301.2	6,458,359.7

Road 2 (Group 2) R = 29m, $\Delta = 114^\circ$

Point	Easting	Northing
Centre	395,265.0	6,458,411.0
PC 100	395,265.0	6,458,440.0
CH 110	395,274.8	6,458,438.3
CH 120	395,283.4	6,458,433.4
CH 130	395,289.9	6,458,425.8
CH 140	395,293.5	6,458,416.5
CH 150	395,293.7	6,458,406.6
PT 157.70	395,291.5	6,458,399.2

Road 3 (Group 3) R = 28m, $\Delta = 119^\circ$

Point	Easting	Northing
Centre	395,265.0	6,458,447.0
PC 100	395,265.0	6,458,475.0
CH 110	395,274.8	6,458,473.2
CH 120	395,283.3	6,458,468.2
CH 130	395,289.6	6,458,460.4
CH 140	395,292.7	6,458,451.0
CH 150	395,292.4	6,458,441.0
PT 158.15	395,289.5	6,458,433.4

Road 4 (Group 4) R = 27m, $\Delta = 125^\circ$

Point	Easting	Northing
Centre	395,214.0	6,458,347.0
PC 100	395,214.0	6,458,374.0
CH 110	395,223.8	6,458,372.2
CH 120	395,232.2	6,458,366.9
CH 130	395,238.2	6,458,359.0
CH 140	395,240.9	6,458,349.4
CH 150	395,239.9	6,458,339.4
PT 158.90	395,236.1	6,458,331.5

Road 5 (Group 5) R = 26m, $\Delta = 130^\circ$

Point	Easting	Northing
Centre	395,243.0	6,458,376.0
PC 100	395,243.0	6,458,402.0
CH 110	395,242.8	6,458,400.1
CH 120	395,261.1	6,458,394.7
CH 130	395,266.8	6,458,386.5
CH 140	395,269.0	6,458,376.8
CH 150	395,267.4	6,458,367.0
PT 158.99	395,262.9	6,458,359.3

Road 6 (Group 6) R = 25m, $\Delta = 135^\circ$

Point	Easting	Northing
Centre	395,216.0	6,458,418.0
PC 100	395,216.0	6,458,443.0
CH 110	395,225.7	6,458,441.0
CH 120	395,233.9	6,458,435.4
CH 130	395,239.3	6,458,427.1
CH 140	395,241.0	6,458,417.3
CH 150	395,238.7	6,458,407.6
PT 158.90	395,233.7	6,458,400.3

Road 7 (Group 7) R = 24m, $\Delta = 140^\circ$

Point	Easting	Northing
Centre	395,235.0	6,458,446.0
PC 100	395,235.0	6,458,470.0
CH 110	395,244.7	6,458,467.9
CH 120	395,252.8	6,458,462.1
CH 130	395,257.8	6,458,453.6
CH 140	395,258.9	6,458,443.7
CH 150	395,255.9	6,458,434.2
PT 158.99	395,250.4	6,458,427.6

Instructions for set-out

1. Except for the PC and CENTRE point, do not use the GPS to set out these other chainage points.
2. Check and record these chainages after being set out by TS and tape using the hand held GPS.
3. The GPS displays to metres only.
4. Calculate BRG/DIST misclose.

A2-4-5 Curve Check Observations

Formulae to calculate the mis-closures on the curve

$$BRG = \text{Atan} \left(\frac{dE}{dN} \right) \text{ in correct quadrant}$$

$$\text{Dist} = \sqrt{dE^2 + dN^2}$$

Class _____ Group _____ Road number _____ TD _____
 Out arc _____ Out chord _____

Point	TS E	TS N	GPS E	GPS N	Mis-close dE	Mis-close dN	BRG	Dist
PC								
110								
120								
130								
140								
150								
PT								

Check taping of radii and chords between chainages of the TS set locations on the curve:

Check of Pillar 18 (record last 3 digits of E and N)

Road number _____ Radius: _____ Pillar 18 observations

Point	Radius to	Error	Chord	_____
Centre	to:	to:	Dist	Error
PC			0.0	0.0
110				
120				
130				
140				
150				
PT				

E 395 170.5	N 6 458 362.9	Ht 10.125
1		
2		
3		
4		
5		
6		
Average		
Misclose		
dE		dN
Brg		Dist.

A2-4-6 Example Group Assessment Form

Example of Marking Guide

Assessment Marking Sheet: Group **Class** _____ **Date:** _____

Group + Individual / Total

Student _____	ID _____	Mark + / _____
Student _____	ID _____	Mark + / _____
Student _____	ID _____	Mark + / _____
Student _____	ID _____	Mark + / _____

Laboratory 5. Setting of a horizontal curve.

Assessment form.

Set-up of instrument Correct centring and orientation Levelling circular bubble, Levelling plate bubble	3.0 (group)	
Set-out of TP1, Centre peg using GPS. IP and TP2 using TS and prism/tape 3mks Set-out of pegs (arrows) on radius at chord distances 5mks Checking distance between chainages and radius from centre peg. 2mks Checking set-up from GPS at each chainage and at Pillar 18. Calc δE , δN , BRG, dist 2mks	12.0 (group)	Obs Brg to IP: _____ TD: _____ . Obs TD _____ Long chord _____ . Obs LC _____ Brg to PT: _____ Obs Brg to PT: _____
Individual's calculations parameters set-out details chainage point coordinates 8mks Sketch of the curve (1:200) 2mks	10.0 (individual)	

A2-4-7 Definitions and Formulae.

The simple curve. See Section 8.2.7

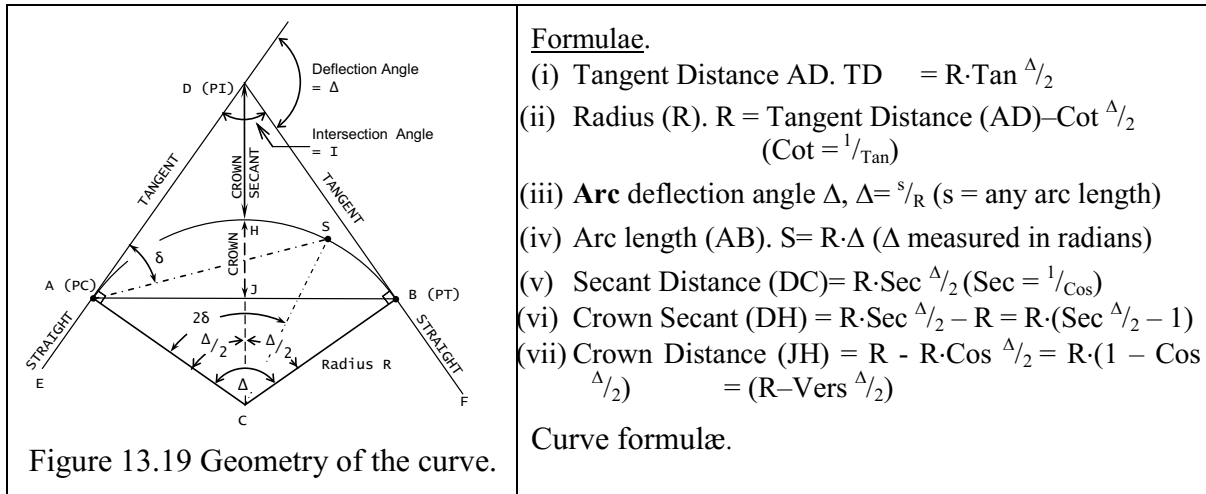

Figure 13.19 Geometry of the curve.

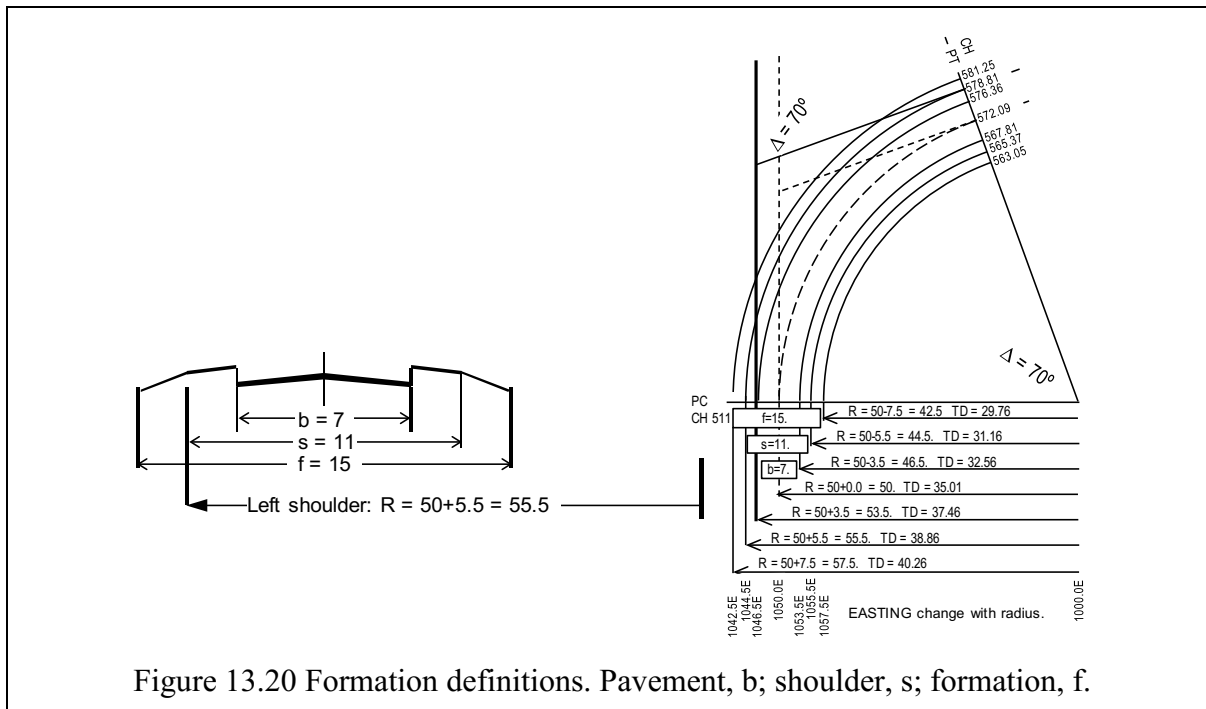

Figure 13.20 Formation definitions. Pavement, b; shoulder, s; formation, f.

	CURVE	EX2	LEFT SHOULDER
Initial direction of tangent	Brg IP =	360	Design TD =
Chainage PC (TP1)	CH =	511.00	CH IP =
Coordinates of PC (TP1)	E =	1050.000	Long chord =
Coordinates of PC (TP1)	N =	5511.000	Arc length, S =
Radius design Centre line	R =	50	Secant distance =
Design deflection angle Δ	$\Delta =$	70	Crown secant =
Through chaining interval	s =	10	Crown distance
Centreline offset	o =	0	CH PT (TP2) =
Pavement width	b =	7	IP E =
Shoulder width	s =	11	IP N =
Formation width	f =	15	

Figure 13.21 Example curve for solution, curve EX2.

Example design parameters for individual curve calculations.

Designed to illustrate a single carriageway road.

Design parameters for curve turning to the RIGHT							
MONDAY CLASS 1 LAB	CURVE	M1	M2	M3	M4	M5	M6
Initial direction of tangent	Brg IP =	360	360	360	360	360	360
Chainage PC (TP1)	CH =	63.50	106.50	107.50	106.50	107.50	105.50
Coordinates of PC (TP1)	E =	1011.000	1012.000	1013.000	1014.000	1015.000	1016.000
Coordinates of PC (TP1)	N =	1018.000	3118.500	3119.500	3120.500	3121.500	3116.750
Radius design Centre line	R =	25	21.5	22.5	23.5	24.5	25.5
Design deflection angle Δ	Δ =	50	85	82	74	72	68
Through chaining interval	s =	5	5	5	5	5	5
Centreline offset	o =	0	0	0	0	0	0
Pavement width	b =	5	5	5	5	5	5
Formation width	f =	8	8	8	8	8	8
Design parameters for curve turning to the RIGHT							
TUESDAY CLASS 4 LAB	CURVE	T1	T2	T3	T4	T5	T6
Initial direction of tangent	Brg IP =	360	360	360	360	360	360
Chainage PC (TP1)	CH =	510.50	511.00	512.00	505.00	506.00	507.00
Coordinates of PC (TP1)	E =	999.000	998.000	997.000	996.000	995.000	1000.000
Coordinates of PC (TP1)	N =	3110.000	3111.000	3112.000	3105.000	3106.000	3107.000
Radius design Centre line	R =	24	25	26	21.5	22.5	23.5
Design deflection angle Δ	Δ =	77	73	70	82	81	79
Through chaining interval	s =	5	5	5	5	5	5
Centreline offset	o =	0	0	0	0	0	0
Pavement width	b =	5	5	5	5	5	5
Formation width	f =	8	8	8	8	8	8
Design parameters for curve turning to the RIGHT							
THURSDAY CLASS 2 LAB	CURVE	W1	W2	W3	W4	W5	W6
Initial direction of tangent	Brg IP =	360	360	360	360	360	360
Chainage PC (TP1)	CH =	408.00	409.00	410.00	411.00	412.00	413.00
Coordinates of PC (TP1)	E =	999.000	998.000	997.000	996.000	995.000	994.000
Coordinates of PC (TP1)	N =	3108.000	3109.000	3110.000	3111.000	3112.000	3113.000
Radius design Centre line	R =	24.5	25.5	26.5	22	23	24
Design deflection angle Δ	Δ =	73	69	66	80	80	76
Through chaining interval	s =	5	5	5	5	5	5
Centreline offset	o =	0	0	0	0	0	0
Pavement width	b =	5	5	5	5	5	5
Formation width	f =	8	8	8	8	8	8
Design parameters for curve turning to the RIGHT							
FRIDAY CLASS 3 LAB	CURVE	F1	F2	F3	F4	F5	F6
Initial direction of tangent	Brg IP =	360	360	360	360	360	360
Chainage PC (TP1)	CH =	207.00	208.00	207.50	211.00	211.00	212.00
Coordinates of PC (TP1)	E =	998.000	997.000	996.000	995.000	994.000	993.000
Coordinates of PC (TP1)	N =	3107.000	3108.000	3109.000	3110.000	3111.000	3112.000
Radius design Centre line	R =	25	24	23	22	21	20
Design deflection angle Δ	Δ =	68	69	72	77	81	83
Through chaining interval	s =	5	5	5	5	5	5
Centreline offset	o =	0	0	0	0	0	0
Pavement width	b =	5	5	5	5	5	5
Formation width	f =	8	8	8	8	8	8

A2-5 Computation of Design Parameters of Vertical Curves

A2-5-1 Practical 6

Task: Solve an assigned survey task

An optional practical assessment, in the form of a desktop exercise, may be made available to students who may wish to replace an existing filed practical mark. The task is designed to represent the amount of work involved in the calculation and reporting of the other assessed reports.

Objective: (REFER TO Appendix A1-2, Chapter 3, Figure 3.1, Table 3-1)

To calculate the formation level of a series of vertical curve between CH 00 and CH 95 of the previously conducted area levelling exercise.

Individual: Individual design and calculation effort.

Equipment: Nil

A2-5-2 Task:

1. You are given the parameters of a vertical curve designed to link the path at CH 00 through to the path at CH 95 through the pine grove to the North of BLD 204.
2. You are provided with the Ground Level (GL) and cross fall on the centre line at CH 00, CH 15, CH 30, CH 45, CH 60, CH 75 CH 90 and CH 95.
3. Your design is for a path excavated to formation level defined by the vertical curve. The side batters have a slope of 1:3 to the surface.
4. Calculate all the parameters of the path at each chainage point using the parameters formation width; **b = 3.0m**
batter slope, **m = 3**,
the ground slope, k_{Left} and k_{Right}

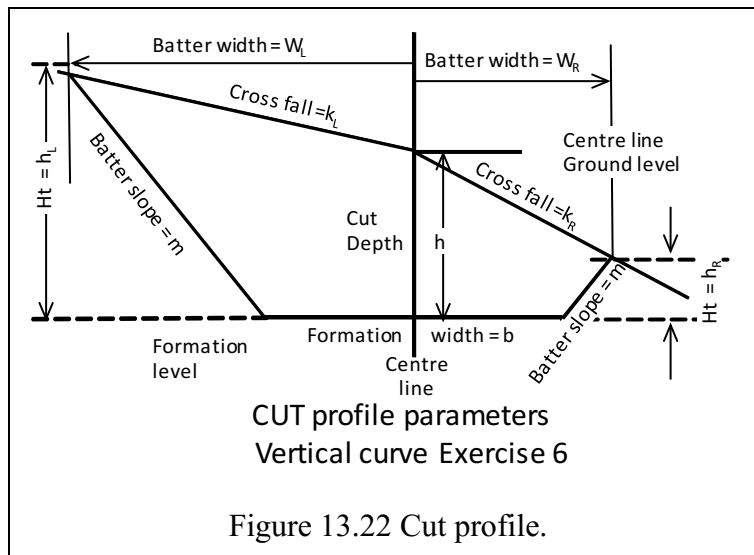

- a) the RL of the path
- b) depth of cut, **h**, at the centre line between GL and path RL
- c) the batter width, W_{Left} and W_{Right} using the batter slope, **m**, at the intersection with the ground slope, **k**,
- d) RL of batter slope at **LEFT and RIGHT** intersection with slope **k**
- e) cross section area by formula or coordinate cross multiplication
- f) volume by end area method, or your choice
- g) Draw and label longitudinal profile of centre line GL and path formation level scale horizontal 1:400, Vertical 1:20.

Vertical Curve design parameters of design surface:

1. The path falls at a slope of -1% between CH 00 and CH 15.
2. The path increases, through a **sag** curve to a slope of $+4\%$ between (CH 15 – CH 30).
3. The path maintains a straight slope between CH30 and CH80.
4. The path again falls, via a **crest** curve, to a slope, -1% , between CH 80 and CH95.

Ground RL and cross slopes

CH	GL	K left	K right
0	11.85	15	Flat (infinite)
15	13.083	14	-15
30	13.444	12	-10
45	14.152	10	-13
60	14.301	15	-25
75	14.535	12	-18
90	14.306	9	-12
95	14.215	Flat (infinite)	Flat (infinite)

Submission:**To your tutor**

1. Calculated path RL at designated chainages. (2mks)
2. Calculated h at each chainage. (4mks)
3. Calculated batter intercepts, distance from CL and intercept RL. (6mks)
4. Calculated end areas at each chainage (6mks)
5. Calculated volume of excavation (3mks)
6. Draw and label longitudinal profile of centre line GL and path formation level scale horizontal 1:400, Vertical 1:20 (4mks)

Assessment 4: Summary of calculated values, Vertical Curve							
Submission date:							
Class:			Group:				
Student ID:			Signature				
Mark Total 25			Mark:				
Comment:							
CH	Finish RL	h	W_L	Ground RL _L	W_R	Ground RL _R	End area
00							
15							
30							
45							
60							
75							
90							
95							
Volume; m ³							
Attach drawing longitudinal profile of centre line GL and path formation level. Scale horizontal 1:400, Vertical 1:20							
Attach calculation sheets for evaluation/confirmation of your answers.							

Example of Marking Guide

Assignment Marking Sheet: Individual. Group _____ Class _____

Student _____ ID _____ Mark _____

Practical 6. Vertical Curve calculations.

Calculated path RL at designated chainages (2mks)		
Calculated h at each chainage. (4mks)		
Calculated batter intercepts, distance from CL and surface intercept RL. (6mks)		
Calculated end areas at each chainage (6mks)		
Calculated volume of excavation (3mks)		
Draw and label longitudinal profile of centre line GL and path formation level. Scale horizontal 1:400, Vertical 1:20 (4mks)		

A2-6 Examples of Interim Reports

Practical A2-1-1.

Determinations of Vertical Control/Vertical Sections (Field Practical 1 and 2):

The aim of Field Practical 1, carried out by the survey team on 5 March 2015, was to establish vertical control over the survey area including:

1. instrument test
2. open traverse to bench mark, D/S134
3. closed traverse through designated control points CEM_8 to CEM_1,
4. check of portal clearance.

The aim of Field Practical 2, carried out by the survey team on 12 March 2015, was to observe ground levels over the designated survey field using spacing for a blasting grid of 6m x 7m. The observation tasks included:

1. establish a 6m x 7m grid from provided survey lines,
2. using control RLs established in task 1, observe designated grid lines
3. determine position of trees and paths based on grid layout,
4. check RL of D/S134

The team members for task 1 and task 2 were:

S. Wright, 12345k	I.M. Bold, 23457f
B. Careful, 24578h	U. Slessor, 05146d

Executive Summary:

Prior to the survey being undertaken the equipment was inspected and tested:

Level: Leica NA724, Asset no 16 (S/N on record)
 Collimation test over 40m line: error 0.004m (4mm). Outside manufacturer's specification.
 Balanced observations taken to ameliorate apparent error.

Staff: Crain 5 section 5m length fibreglass. Good condition, section extension tested for wear.
 No error measured over section joint.

Task 1 (Practicals 1 and 2) was carried out by the team to determine the surface levels of the designated survey area so that the levels could be incorporated in to a Digital Elevation Model (DEM) for further processing in a GIS program. Initial calculated values are designed to provide a check of subsequent GIS results.

The site itself is approximately 63m x 42m (2650m²) between the Civil Engineering building 204 and the Library, building 105 on Curtin Campus. The site slopes down in a generally easterly direction from an RL of 18.5m to a girding bench at 15.5m.

Vertically excavated in-situ volume of material to a bench level of 15.5m is approximately 2900m³.

Vertical drilling to bench level involves some 85m over 55 drill holes; using a 250mm (10") rotary drill produces 4m³ of spall for explosives stemming.

All measurements were recorded in the field book, calculated by either the rise and fall method (practical 1) and the height of collimation method for practical 2. The reductions were checked for agreement between the readings, reductions and resulting levels.

The closed traverse to determine control benchmark RLs and D/S134 was run between station C954 and C153. The overall vertical misclose was 0.013m (13mm) which was within specifications.

Comparing the level at D/S134 against the open traverse showed a misclose of 0.010m (10mm).

The portal clearance was determined to be 3.210m, agreeing with the advised clearance.

Practical 2 was initiated by the set-out of the 6m x 7m blast grid being flagged by sprinkler flags. From control point CEM_8, RL determined in practical 1, the nominated lines of the blast field were observed and the observations were closed back to CEM_8. D/S134 was levelled and found to agree within 0.015m (15mm) of practical 1 observations. Reduction of grid levels was by the height of collimation method. The closure, through two change points, back to CEM_8 was confirmed by the rise and fall method, with a misclose of 0.010m (10mm).

The approximate positions of trees and pathways within the survey area were recorded in relation to the blast grid coordinates. A representative tree was measured to ascertain total tree volume over the site.

A précis of results, with examples of reduction methods, is appended, together with a copy of the reduced field book. Plans and cross sections are attached.

Signed. S.Wright 17/08/2015

A3 Civil Engineers Practicals

A3-1 Civil Engineers Practicals 1

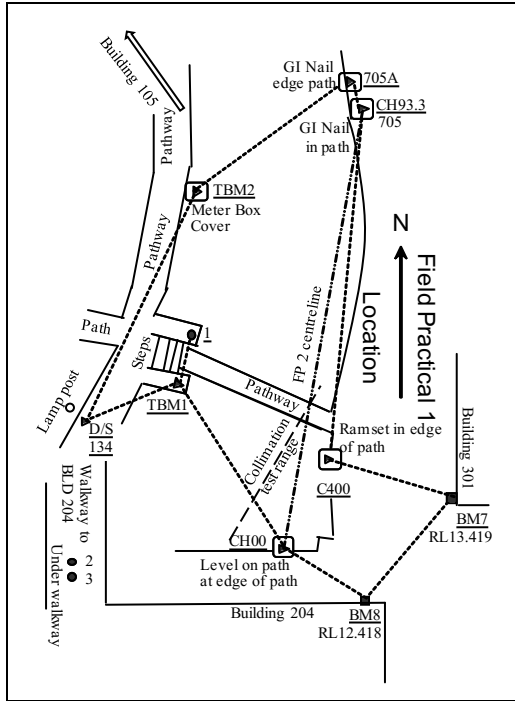

Location, instructions.

Appendix

A2-2

Description of task. FP 1

A2-2-1

Field work.

- Collimation test by each team member

- Open traverse from BM8. Sequence:

- BM8, CH00, clearance at 2 & 3, D/S134.

- Closed traverse from BM8. Sequence: BM8, CH00, TBM1, 1, D/S134, TBM 2, 705, 705A, C400, BM7, BM8.

Measurement and reduction:

Section 2.5

- Instrument set-up

Section 2.4.1

- Collimation test

Section 2.4.5

- Differential Levelling rise & fall;

Section 2.5.3

- Area levelling

Section 2.5.6

Calculation of observations

Section 2.5.4

Recording of Practical Tasks:

ALL observations are to be entered in supplied Field Book.

Record readings as provided on **Rise and Fall** booking sheet in the FB. Records must be NEAT.

- Record readings in metres, staff read (estimated) to millimetre level (3DP).

- Staff sections extended correctly (check that there is not a closed section, 1m error)

Observe the rules of levelling

Section 2.5.1

Sequence of Practical tasks:

1. Collimation check, individual observations (move instrument & re-level)
Team members each observe from mid-point, then from **close** (2 – 3m) to one staff.
2. Set level; observe BM8, BM8, points 2 & 3, and change point for open traverse to D/S134
BS BM8 (plug), 3 intermediate sights (IS) to portal, FS to firm CP1 (BS = FS distance).
3. Move level to allow sight to D/S134 and CP1
BS to CP1, FS to D/S134. End of open traverse.
4. Return level to allow back sight to BM8
BS to BM8, IS to CH00 FS to a change point (CP1)
5. Move level to allow sight to CP1, TBM1, D/S 134 and TBM2. Points inter-visible?
BS to D/S134, IS to TBM1, D/S 134, TBM1 and FS to TBM2 as CP2. (BS = FS distance).
6. Move level to allow sight to CP2, (TBM2) and forward to about 705/705A
BS to CP2, IS to 705, FS to 705A as CP3.
7. Move level to allow sight to CP3 (705A) and forward to about C400
BS to CP3, FS to C400 as CP4.
8. Move level to allow sight to CP4, with sight line to close on BM7
BS to CP4, IS to BM8 (check), FS to BM7. Complete closed traverse.
9. Calculate rise/fall and RLs to find misclose. Acceptable at 0.015m?
10. Calculate RLs of each point.
Compare levels D/S134 between open and closed traverse. Check misclose to BM8.

Field reduction of Level observations:

ALL observations should be reduced in the field. The booker has plenty of time between level readings to calculate the rise/fall between points.

Each team member check their own collimation observations. Acceptable at 0.003m?

Draw and label a sketch of the field set-out. Indicate level position and CPs used.

Ensure FB is completed correctly. It's worth 25% of evaluation and is the only acceptable record of observation. Any loose sheets **MUST** be submitted with the FB. No erasures of data. Strike the error out and write the new entry adjacent the error. Any "fair copy" must have original data in support.

A3-2 Civil Engineers Practical 2

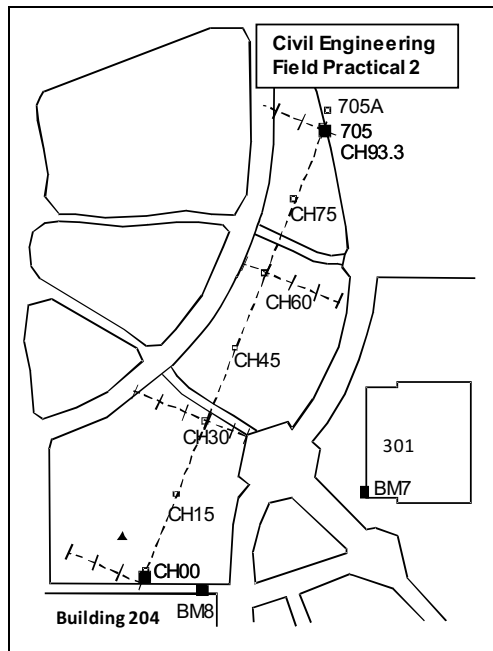

Location, instructions.

Appendix	A2-2
Description of task. FP 2	A2-2-2
Field work.	
Establishment of perpendicular offset grid	Section 2.6.4
Area levelling of grid from CH00	
Recording and reduction by Height of Collimation	Section 2.5.7
Mapping of trees, paths in exercise area,	
Measure tree with tape and clinometer.	Section 2.6.5
Field data reduction:	Section 2.5.4
Recording of Practical Tasks:	
ALL observations are to be entered in supplied Field Book.	
Record readings as provided on Rise and Fall booking sheet in the FB. Records must be NEAT.	
- Record readings in metres, staff read (estimated) to millimetre level (3DP).	
- Staff sections extended correctly (check that there is not a closed section, 1m error)	Section 2.7.3
Observe the rules of levelling	Section 2.5.1

Because of the compressed dimensions of the site, groups may start anywhere along the centreline. Start at the nearest established TBM (Field Practical 1) and sequentially survey the centreline and offsets. Include FP1 TBMs during the traverse

Sequence of Practical tasks:

Starting at CH00 as TBM, or any other TBM.

1. Sequentially level centreline and offsets. TBM 2 could allow a start at CH 45 or CH 60. This method requires accurate booking of chainage and offsets. CL pegs may be used as CPs.
2. Complete the traverse of the centreline and close to a TBM.
3. Set level to allow BS on your control point (CH00) with an extensive view of site; observe CH00 as BS, IS to grid intersections and a FS to firm change point (CP1)
4. Move level to allow sight to CP1 and remainder of survey field
BS to CP1, IS to grid intersections and a FS to firm change point CP2.
5. Observe the assigned grid intersections, using change points as necessary, include levelling to D/S134 as a check.
6. Calculate RLs by HC method.
7. Use Rise and Fall method to check between CH00, the CPs and D/S134. Establish misclosure with values from FP1.
8. Record position of trees by using chainage and offset method from the centreline, CH00 to CH93.3.

Measure one tree for timber volume using clinometer and tape.

Field recording of Level observations. The booker should "keep up" with observations, ensuring correct identification of grid lines. Levels need to be correctly placed

Draw and label a sketch of the field set-out. Indicate level position and CPs used. Complete FB.

A3-3 Civil Engineers Practical 3

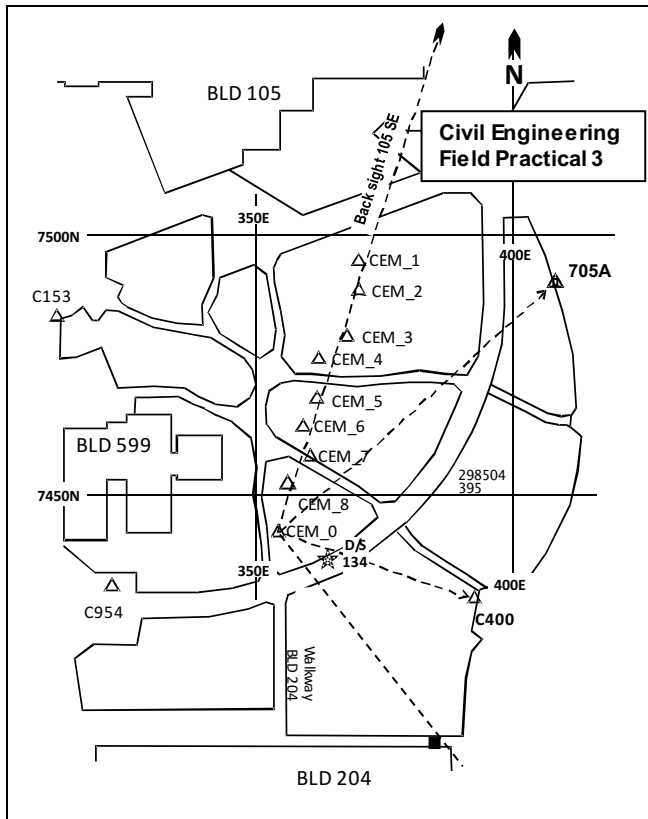

Location, instructions

Appendix	A2-3
Description of task. FP 3	A2-3-1
Field work.	
Set-up Total Station	Section 4.2.4
Azimuth for orientation	Section 4.2.4.3
Instrument height	
Target height, prism constant	
Observation, booking,	Section 4.3.1
Backsight (RO), NE204, D/S134	
Pick up trees, paths in designated area surrounding CEM_1 to CEM_4	
Recording of TS observations	
Booking	Section 4.6.2
Field data reduction:	Section 4.7
Recording of Practical Tasks:	
ALL observations are to be entered in supplied Field Book.	
Record readings on provided Traverse booking sheet in the FB.	
Records must be NEAT.	
- Record angles to second, distances in metres to millimetre level (3DP).	
- Ht instrument, target in metres to mm.	
Control point data:	
360° mini-prisms set over points.	
705A: E407.808, N7491.205, RL from FP1.	
C400: E392.107, N7428.494, RL from FP1.	

Sequence of Practical tasks:

1. Set and level TS over designated control point (CEM_1 – CEM_8)
2. Draw station diagrams. Measure and record HI of TS, HT of prisms.
3. Set Prism Constant (PC) as PC +3 (360° mini-prism).
4. Set and align TS to magnetic meridian with tube compass.
5. Set HAR to read TRUE AZIMUTH using H.ANG function on TS Section 4.2.4.2
6. Establish **Back Sight** feature.
Observe HAR only for reference alignment to BS on FL.
7. Read and record in sequence: HAR, ZA, Slope distance
FL: 705A
FL: C400
FR: C400
FR: 705A
FR: BS. HAR only.
8. Change TS PC to PC -30
9. Set prism on prism pole and set to height of instrument (HI)
10. Observe and book on **Face Left only**: ZA, HAR, Slope Distance for:
NE corner of Building 204, for establishment of proposed building set-out
D/S134 (comparison of level from FP1 and 2)
11. Using the supplied reflector held at approximately height of instrument (HI), continue the topographic survey of features; path edges, trees, sumps etc. within area containing CEM_1 to CEM_4. (topography plan and levels for building design).

A3-4 Civil Engineers Practical 4

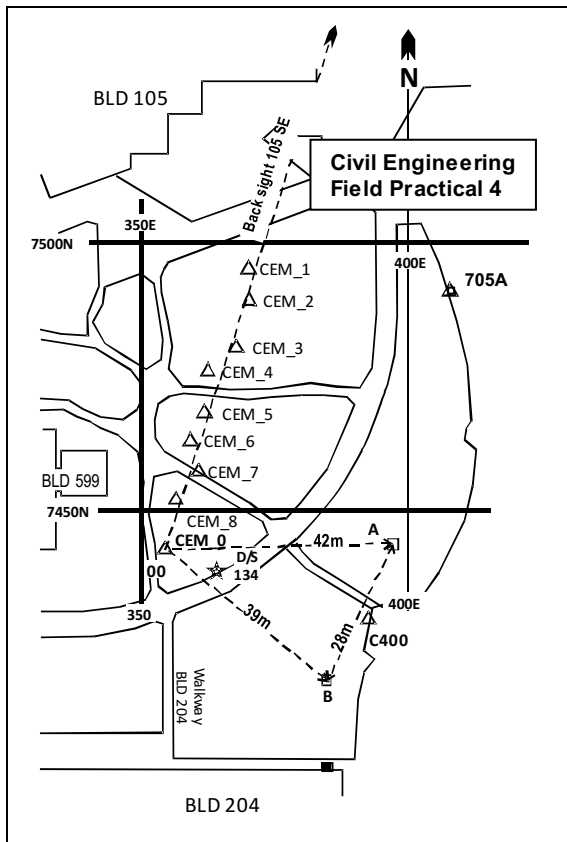

Location, instructions.

Appendix	
Description of task. FP 4	A2-3-2
Field work.	
Set-up Total Station	Section 4.2.4
Azimuth for orientation calculated from FP3	
Instrument height (HI)	
Set up prisms over control points, layout	A2-3-2
Target height (HT), prism constant	
Observation, booking,	Section 4.3.1
Backsight (RO), azimuth from FP3	
Recording of TS observations	
ALL observations are to be entered in Field Book.	
Record as provided on FB booking sheet in FB:	
height of instrument at 00 (HI),	
height of targets A and B (HT).	Section 4.2.2
Booking	Section 4.6.2
Semi-forced centring around network	A2-3-2
Field data reduction:	Section 4.7
Recording of Practical Tasks:	
Prism constant correction PC-30mm	
TRUE bearing of BACKSIGHT	
Sequence of observations	
Calculation of observations	Section 5.5
Reduction of observations	Section 5.5.1
Adjustment of observations	Section 5.5.2
Bowditch method	Section 5.5.4
Calculation of area	Section 5.5.5

Sequence of Practical Tasks:

1. Set and level TS over designated control point (CVEN_1 – CVEN_8) (**STN 00**)
2. On lower grassed area set two control points, A and B, pegged as designated in the figure. Triangle sides about 45m, 25-30m and 45m. Ensure inter-visibility between points. Use flagging tape to aid identification of **your** targets.
3. Set-up and level prism set over each point (**A** and **B**).
4. Draw and label a sketch of the field set-out.
5. Set Prism Constant (PC) as **PC -30**.
6. Re-establish Field Practical 3 **Back Sight** feature pointing.
7. Set HAR to read TRUE BRG to backsight using H.ANG function on TS (enter as D.MMSS) (Section 4.2.4.2). Calculated after FP 3.
8. From STN 00, read and record: Slope distance, ZA, HAR in sequence; FL: BS – FL: A – FL: B. Plunge TS; FR: B – FR: A – FR: BS.
9. Swap TS with prism at **A. Remove instrument and prism from tribrach using lock.**
10. At STN A. Sight to left of STN B and use **0 SET** on TS screen P1
Read and record: Slope distance, ZA, HAR in sequence;
FL: B – FL: 00. Plunge TS; FR: 00 – FR: B.
11. Swap TS with prism at **B. Remove instrument and prism from tribrach using lock.**
12. At STN B. Sight to left of STN 00 and use **0 SET** on TS screen P1
Read and record: Slope distance, ZA, HAR in sequence;
FL: 00 – FL: A. Plunge TS; FR: A – FR: 00.
13. If requiring any further Topographic features for FP3. Set prism pole and prism to HI. Re-establish STN 00, set BS true BRG and observe **Face Left only**.

A4 Mining Engineers Practicals

A4-1 Mining Engineers Practical 1

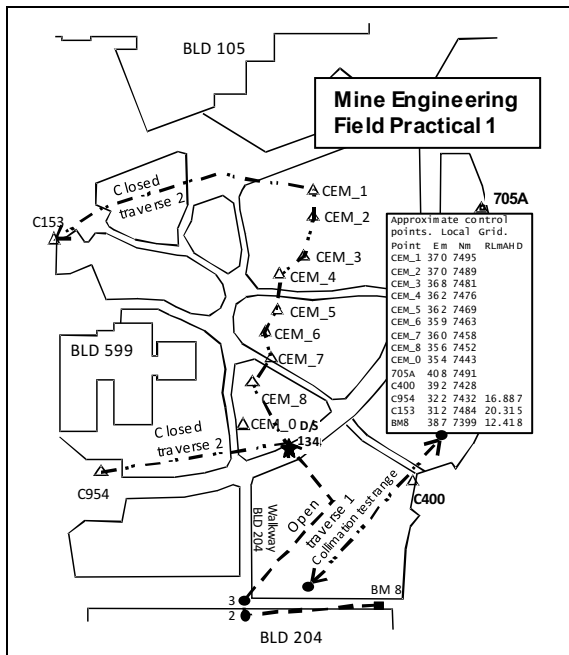

Location, instructions.

Reference: Appendix A2-2

Description of task. FP 1

A2-2-1

Field work.

Collimation test by each team member

Open traverse from BM8. Observations sequence:

BM8, portal clearance at 2 & 3, D/S134

Closed traverse from C954.

Observations sequence: C954, D/S134, CEM_8 – CEM_1, C153

Measurement and reduction:

Instrument set-up

Collimation test

Differential Levelling rise & fall;

Area levelling

Calculation of observations

ALL observations are to be entered in supplied Field Book. Record readings as provided on **Rise and Fall** booking sheet in the FB.

Records must be NEAT.

Record readings in metres, staff read (estimated) to millimetre level (3DP).

Staff sections extended correctly (check that there is not a closed section, 1m error)

Comply with rules of levelling

Section 2.5

Section 2.4.1

Section 2.4.5

Section 2.5.3

Section 2.5.6

Section 2.5.4

Section 2.5.4

Section 2.5.1

Sequence of Practical Tasks:

- Collimation check, individual observations (move instrument & re-level)
Each team member observe from mid-point, then from **close** (2 – 3m) to one staff.
- Set level; observe BM8, portal points 2 & 3, and change point for open traverse to D/S134
BS BM8 (plug), two intermediate sights (IS) to portal, FS to firm CP1 (BS = FS distance).
- Move level to allow sight to D/S134 and CP1
BS to CP1, FS to D/S134. (BS = FS distance). End of open traverse.
- Move level to allow sight to control point C954 and D/S134
BS to C954, FS to D/S134. (BS = FS distance). D/S134 is CP1
- Move level to allow sight to CP1, D/S134 and forward to about CEM_4. Points inter-visible.
BS to D/S134, IS to CEM_8 and other CEM points, FS to CEM_4 as CP2.
- Move level to allow sight to CP2, D/S134 and forward to about CEM_4
BS to D/S134, IS to CEM_8 and other CEM points, FS to CEM_4 as CP3.
- Move level to allow sight to CP3 (CEM_4) and forward to about CEM_1
BS to CP3, IS to remaining CEM points, FS to CEM_1 as CP4.
- Move level to allow sight to CP3, with sight line to close on C153
BS to CP4, FS to C153. (BS = FS distance) Complete closed traverse.
- Calculate rise/fall and RLs to find misclose. Acceptable at 0.015m?
- Calculate RLs of each point.

Compare levels D/S134 between open and closed traverse

Field reduction of Level observations:

ALL observations should be reduced in the field. The booker has plenty of time between level readings to calculate the rise/fall between points.

Each team member check their own collimation observations. Acceptable at 0.003m?

Draw and label a sketch of the field set-out. Indicate level position and CPs used.

Ensure FB is completed correctly. It's worth 25% of evaluation and is the only acceptable record of observation. Any loose sheets **MUST** be submitted with the FB. No erasures of data. Strike the error out and write the new entry adjacent the error. Any "fair copy" must have original data in support.

A4-2 Mining Engineers Practical 2

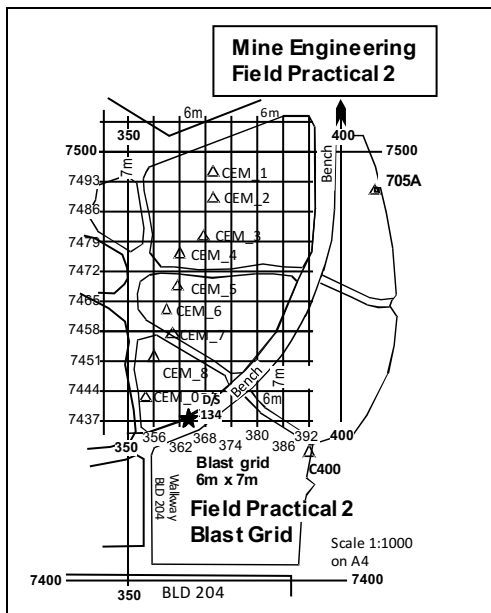

Location, instructions.

Reference:

Appendix A2-2

Description of task. FP 2

Section A2-2-2

Field work.

Establishment of blast grid

Section 2.6.3

Area levelling of grid from assigned control BM

Recording and reduction by Height of Collimation (HC)

Locate trees within grid squares.

Measurement and reduction (HC)

Area levelling, HC method

Section 2.5.7

Calculation of observations

ALL observations are to be entered in supplied Field Book. Record readings as provided on **Height of Collimation (HC)** booking sheet in the FB.

Records must be NEAT.

Record readings in metres, staff read (estimated) to millimetre level (3DP).

Staff sections extended correctly (check that there is not a closed section, 1m error)

Comply with rules of levelling

Section 2.5.1

Sequence of Practical Tasks:

Because of the amount of data to be gathered, the grid lines will be split between the anticipated two survey classes, in line with the plotting requirements of the assignment. Your starting bench mark is an assigned BM from CEM_1 to CEM_8. Level determined in FP1.

Starting at 350E grid line.

- 1st practical class: Level cross section at 7500N grid line, then every 14m south. i.e., at 7486N, 7472N, 7458N and 7444N.
- 2nd practical class: to interleave with the 1st practical class. Level cross section at 7500N and 7493N grid lines and then every 14m south. i.e., at: 7479N, 7465N and 7451N.
3. The check vertical datum by closing the level of D/S134.

Sequence of Practical Tasks:

ALL observations are to be entered in supplied Field Book.

Record readings as provided on **Rise and Fall** booking sheet in the FB. Records must be NEAT.

Re-label the **Fall** column heading as **HC**. **The Rise column will not be used.**

$$HC = RL_{\text{start BM}} + BS$$

$$RL_{\text{point}} = HC - IS/FS. \text{ FS is read at CP before moving level.}$$

Record readings in metres, staff read (estimated) to millimetre level (3DP).

Staff sections extended correctly (check that there is not a closed section, 1m error)

1. Set level to allow BS on your control point (CEM_1 – CEM_8 as assigned) with an extensive view of site; observe CEM_ BM as BS, IS to grid intersections and a FS to firm change point (CP1)
2. Move level to allow sight to CP1 and remainder of survey field BS to CP1, IS to grid intersections and a FS to firm change point CP2.
3. Observe the assigned grid intersections, using change points as necessary, until levelling is closed at D/S134
4. Calculate RLs by HC method.
5. Use Rise and Fall method to check between CEM_ BM, the CPs and D/S134. Establish misclosure with values from FP1.
6. Record position of trees by estimation from grid intersections. Measure one tree for timber volume using clinometer and tape.

Field recording of Level observations. The booker should "keep up" with observations, ensuring correct identification of grid lines. Levels need to be correctly placed

Draw and label a sketch of the field set-out. Indicate level position and CPs used. Complete FB.

A4-3 Mining Engineers Practical 3

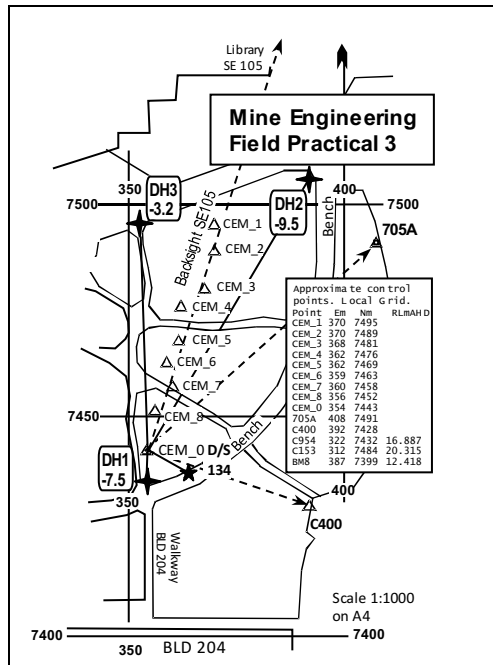

Location, instructions

Appendix

Description of task. FP 3

A2-3-1

Field work.

Set-up Total Station

Section 4.2.4

Grid bearing for orientation

Section 4.7.1

Calculate BRG to 705A

from supplied coordinates

Section 4.7.1.1

Instrument height (HI)

Target height (HT), prism constant

Section 4.3.1

Observation, booking,

Backsight (RO), DH1, DH2, DH3, D/S134

Pick up trees, paths in site area surrounding

CEM_1 to CEM_4 to bench wall.

Recording of TS observations

Booking

Section 4.6.2

Field data reduction:

Section 4.7

Intersection by distance: calculations

Section 6.3.2

DTM observations

Section 6.3.4

Control point data: grid as supplied

360° mini-prisms set over points.

705A: E408, N7491, RL from FP1.

C400: E392, N7428, RL from FP1.

Recording of Practical Tasks:

ALL observations are to be entered in supplied Field Book.

Record readings on provided **Traverse** booking sheet in the FB. Records must be NEAT.

- Record angles to second, distances in metres to millimetre level (3DP).
- Ht instrument, target in metres to mm.

Sequence of Practical Tasks

ALL observations to be entered in Field Book.

Record as provided on FB booking sheet

Height of instrument, height of targets at 705A, C400

1. Set and level TS over designated control point (CEM_1 – CEM_8)
2. Draw station diagrams.
3. Set Prism Constant (PC) as PC +3.
4. Set and align TS to 705A
5. Set HAR to read TRUE AZIMUTH using H.ANG function on TS Section 4.2.4.2
6. Establish **Back Sight** feature. Observe HAR only for reference alignment to BS on FL.
7. Read and record in sequence: Slope distance, ZA, HAR
 FL: 705A
 FL: C400
 FR: C400
 FR: 705A
 FR: BS. HAR only.
8. Change TS PC to PC -30
9. Set prism on prism pole and set to height of instrument (HI)
10. Observe and book on **Face Left only**: ZA, HAR, Slope Distance for:
 D/S134 (comparison of level from Prac 1 and 2)
 DH1, DH2 and DH3 for calculation of seam level.
11. Using the supplied reflector held at approximately height of instrument (HI), continue the topographic survey of features; path edges, trees, bench wall. (topography plan and levels for excavation).

A4-4 Mining Engineers Practical 4

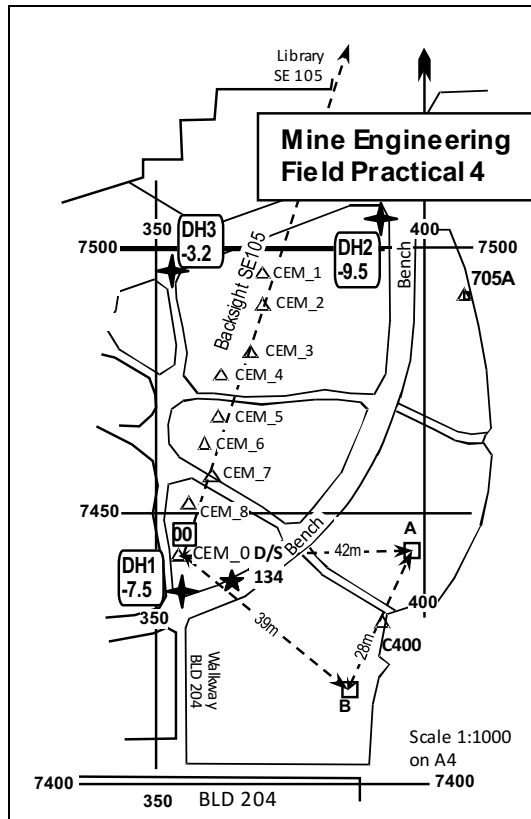

Location, instructions.

Appendix

Description of task. FP 4

A2-3-2

Field work.

Set-up Total Station

Section 4.2.4

Azimuth for orientation calculated from FP3

Instrument height (HI)

Set up prisms over control points, layout

A2-3-2

Target height (HT), prism constant

Observation, booking,

Section 4.3.1

Backsight (RO), azimuth from FP3

Recording of TS observations

ALL observations are to be entered in Field Book.

Record as provided on FB booking sheet in FB:

height of instrument at 00 (HI),

height of targets A and B (HT).

Section 4.2.2

Booking

Section 4.6.2

Semi-forced centring around network

A2-3-2

Field data reduction:

Section 4.7

Recording of Practical Tasks:

Prism constant correction **PC-30mm**

TRUE bearing of **BACKSIGHT**

Sequence of observations

Section 5.5

Calculation of observations

Section 5.5.1

Reduction of observations

Section 5.5.2

Adjustment of observations

Section 5.5.4

Bowditch method

Section 5.5.5

Calculation of area

Sequence of Practical Tasks:

1. Set and level TS over designated control point (CVEN_1 – CVEN_8) (**STN 00**)
2. On lower grassed area set two control points, A and B, pegged as designated in the figure. Triangle sides about 45m, 25-30m and 45m. Ensure inter-visibility between points. Use flagging tape to aid identification of **your** targets.
3. Set-up and level prism set over each point (**A and B**).
4. Draw and label a sketch of the field set-out.
5. Set Prism Constant (PC) as **PC -30**.
6. Re-establish Field Practical 3 **Back Sight** feature pointing.
7. Set HAR to read TRUE BRG to backsight using H.ANG function on TS (enter as D.MMSS) (Section 4.2.4.2). Calculated after FP 3.
8. From STN 00, read and record: Slope distance, ZA, HAR in sequence; FL: BS – FL: A – FL: B. Plunge TS; FR: B – FR: A – FR: BS.
9. Swap TS with prism at **A. Remove instrument and prism from tribrach using lock.**
10. At STN A. Sight to left of STN B and use **0 SET** on TS screen P1
Read and record: Slope distance, ZA, HAR in sequence;
FL: B – FL: 00. Plunge TS; FR: 00 – FR – B.
11. Swap TS with prism at **B. Remove instrument and prism from tribrach using lock.**
12. At STN B. Sight to left of STN 00 and use **0 SET** on TS screen P1
Read and record: Slope distance, ZA, HAR in sequence;
FL: 00 – FL: A. Plunge TS; FR: A – FR: 00.
13. If requiring any further Topographic features for FP3. Set prism pole and prism to HI. Re-establish STN 00, set BS true BRG and observe **Face Left only**.

A4-5 CIVIL and Mining Engineers Practical 5

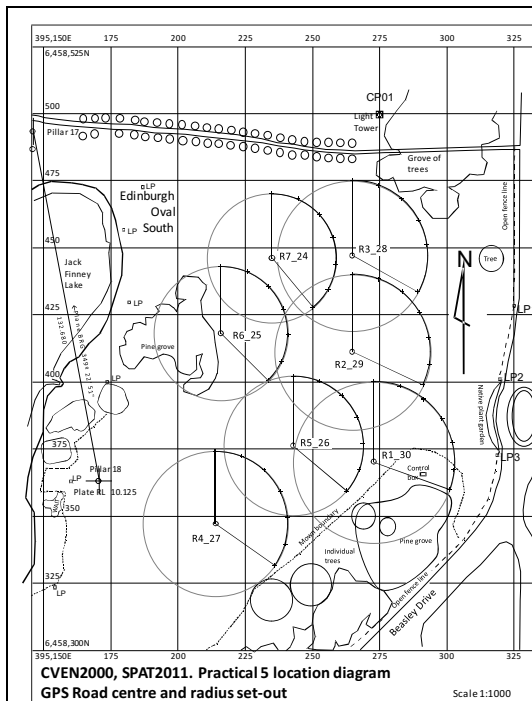

Field examination

Appendix A2-4
 Description of task. FP 5 A2-4-1

Set-out and check assigned circular curve. use allocated sprinkler pins for marking curve. Field work.

Locate PC and centre point (O) by hand-held GPS from given coordinates of assigned curve.

MGA coordinates use 25mm pegs.

Set-up TS and conduct examination tasks as specified for assigned curve. A2-4-1

Mini prism constant correction **PC-20mm**

Orientation as specified to radius centre. Calculate tangent distance set out and mark **IP** by TS and **prism**

Set out and mark curve by TS bearing and **taped** distance

Inform examiner on completion of set-out

Examiner will evaluate curve using TS.

Check chainage points,

check radius; check in, through and out chords

observations with GPS, check mis-closures.

Check hand-held GPS at known control point.

Set and level Total Station (TS) over designated PC

Group: _____ **Curve no.** _____ **MGA E:**

_____, **MGA N** _____

1. Set-up

- a. Set BRG 360° to centre on face left (**FR**). Use 0_SET on FR and plunge TS to point 360 on FL.
- b. Set out and mark tangent distance to **IP** using mini-prism.
- c. Set out chainages using given BRG and distance, by 60m cloth tape. Mark with sprinkler flags.

2. Concurrent with set-out, other team members

Calculate tangent distance to **IP**

chainage, coords IP

Arcs and chords:

BRG _____ **TD** _____

CH_{IP} _____ **E** _____, **N** _____

In arc _____, **in chord** _____

through arc _____, **through chord** _____

out arc _____, **out chord** _____

3. On completion of chainage set-out; **before dismantling TS setup.**

4. Advise examiner that set-out complete so that task can be evaluated.

- a. Team to measure and record radius to each chainage chord distance **between** each chainage point.
- b. calculate errors in both radii and individual chord distances.

5. Begin GPS pickup of chainage points and Pillar 18.

- a. Record last 3 digits of MGA coordinates of each point, include TP1 and centre point.
- b. Record last 3 digits of MGA coords and height at Pillar 18. Take 6 observations, average. Compare with known coordinates.
- c. Calculate misclose distances between set-out and observed coordinates.
- d. Present completed calculations to examiner for evaluation and marking.

The exercise relies on teamwork within the group; some working with the TS on set-out, others performing pre-calculations, check measurements, observations with GPS, calculations of misclose distances. Rotate tasks.

A5 Survey Calculations on the HP 10s+

A5-1 Introduction

The HP 10s+ Scientific Calculator is the calculator specified for use in engineering examinations. Consult your user manual, not particularly informative, on the basic functions of the calculator.

A5-1-1 Set-up for surveying.

Getting up the calculator ready for survey computations involves the **MODE** key for setting base parameters.

First press **MODE** 1 COMP for computations,

Next press **MODE** 1 Deg for degrees mode,

Third press **MODE** 1 Fix, press 1 for

Fix 0~9?

choose 6 to maintain precision if you are not using memory locations for Ans storage.

A5-1-2 Time/angle calculations:

You can use the **°'"** key to manipulate angles. The display uses the degree $^\circ$ symbol as the unit (minutes, seconds) separator. ($125^\circ 28' 37''$).

$125^\circ 28' 37''$ is input as 125 **°'"** 28 **°'"** 37 **°'"**. The top line, the display **input** line, will show $125^\circ 28' 37''$. Pressing **=** puts $125^\circ 28' 37''$ in the second line as the **output**, or result line. Importantly, it is the line that fills the Ans memory, after the **=** key is used. Using the **°'"** key will toggle the Ans line between $125^\circ 28' 37''$ and 125.476944, but the Ans memory only holds $125^\circ 28' 37''$. This means you can't convert DMS to decimal degrees to use for following calculations (converting to radians, say).

A5-1-3 DMS to decimal degrees: on Ans line.

The **°'"** key toggles between Degrees, Minutes, Seconds (DMS) and decimal degrees display on the Ans line:

$125^\circ 28' 37''$ **°'"** 125.476944.

The degrees display expressed as degrees, minutes, seconds ($125^\circ 28' 37''$) returns an Ans to any problem in the same format: degrees, minutes, seconds.

If you input **decimal** degrees, you can convert them to DMS after pressing **=** to put them in the Ans line, then use **°'"** to toggle to DMS.

125.4769 **=** 125.4769 **°'"** $125^\circ 28' 36.8''$, but the Ans memory will still hold the decimal input, 125.4769.

If you want to convert DMS to decimal and use the decimal value in chain calculations you must do it on the input line: $125+28\div 60+37\div 3600$ **=** 125.476944, which will be in the Ans buffer.

A5-1-4 Degrees to Radians:

A nasty, tricky conversion with this calculator, and there are several ways to handle it:

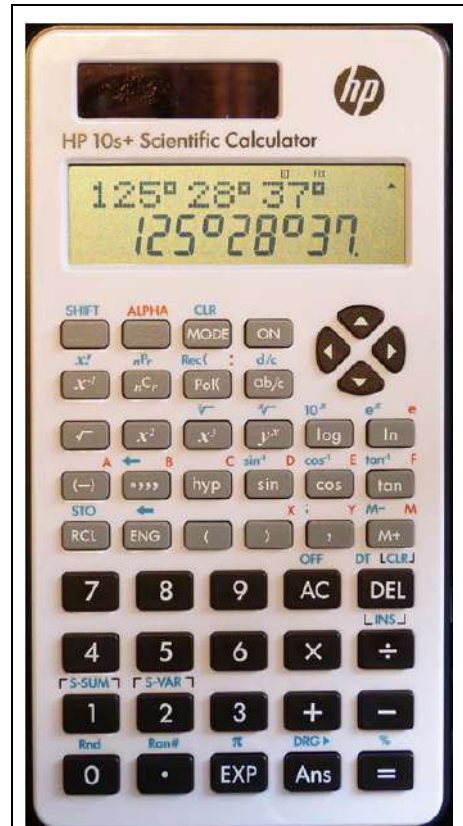

HP 10s+ Scientific Calculator.



1. The old faithful: $\text{Deg} \times \pi \div 180$ [=] unfortunately it provides a funny looking answer if you use the [°"] input:
 $125^\circ 28' 37'' \times \pi \div 180 = 2^\circ 11' 23.95$ This is, in fact, the correct answer to the problem of dividing $125^\circ 28' 37''$ by 57.29578 ($180/\pi$). It is expressed in degrees, minutes, seconds! However, it is incorrect in this case because radians are decimals. You have to use the [°"] key to get 2.189986 , the correct answer in radians.
2. The new faithful, using a memory [STO] (SHIFT RCL) in a memory location A - D, to store the number of degrees in a radian. 57.29578 ($\pi/180$).
 $180 \div \pi$ [=] 57.29578 [STO] (SHIFT RCL) A
 $125^\circ 28' 37'' \times A$ [=] $2^\circ 11' 23.95$. then use the [°"] key to get 2.189986 .
3. Frogging around using the DRG key (SHIFT Ans), probably forget it.
4. Work in decimal degrees and use either 1 or 2 above. But you must convert DMS to decimal degrees to decimals first;
 $125 + 28 \div 60 + 37 \div 3600$ [=] 125.476944 , then [Ans] $\div A$ [=] 2.189986 ,
5. Consult h20331.www2.hp.com/Hpsub/downloads/10s_03_operating_modes.pdf.

A5-1-5 Why Radians to Degrees?

A little bit easier, and where is it needed? With circular curves, that's where.

Curve or arc length is an expression of the distance around the arc of radius generated by an angle between the end radii of the arc.

Arc distance, $S = R \theta$ (radians) where θ is the arc deflection angle (at the centre).

If we are given radius, R, and arc length, S, then:

arc deflections, $\theta = S/R$ expressed in **radians**.

In this book, concerning circular curves, we tend to use the symbol Δ (delta) because it denotes the **deflection** angle between two tangents joined by a circular curve. It is the same as the **arc** deflection angle at the centre between the two radii joining the PC and the PT.

Radians to Degrees:

The radian answer will come from a computations like, for example:

$$328.498 \div 150$$
 [=] 2.189986 .

The usual conversion with this calculator :

1. The old faithful: $\text{Radians} \times 180 \div \pi$ [=]
[Ans] $\times 180 \div \pi$ [=] 125.460556 is the answer in decimal degrees.
It can be converted to DMS using the [°"] $125^\circ 28' 37''$
2. The new faithful, using a memory [STO] (SHIFT RCL) in a memory location A - D, to store the number of degrees in a radian. 57.29578 ($\pi/180$).
 $180 \div \pi$ [=] 57.29578 [STO] A. then, from the previous answer (scroll to it):
[Ans] $\times A$ [=] 125.460556 , then use the [°"] key to get $125^\circ 28' 37''$. But the value in Ans will still be in decimal degrees.

A5-2 Vector Conversion and Axes Rotation.

Normal polar vectors are represented in a mathematically oriented (anticlockwise) frame. Zero degree axis is along the + x axis, pointing horizontally to the right. The vector rotates anticlockwise to 90° through the + y axis, 180° through - x, 270° through - y and back to 360° at +x.

Surveying polar vectors are represented in an azimuthally (clockwise) oriented frame. Zero degrees points vertically up to North (N, +y). It then rotates **clockwise** to 90° on the East axis

(E, +x), 180° on the South axis (-N, -y), 270° on the West axis (-E, -x) and returns to 360° on the N axis.

To use the SHIFT **Pol(** and **Rec(** functions we have to swap our rectangular coordinate orientation to make the calculator think it's working in math orientation. The polar coordinates don't change, it's only the rectangular coordinates that need understanding.

A5-2-1 Them (the US) and Us (Australia)

A word on the difference between rectangular/polar coordinate order using the SHIFT **Pol(** and **Rec(** functions in azimuth vector mode.

The HP10S+ (and all its ilk) conform to the American order of:

N (Latitude distance, y), E (Departure distance, x) for rectangular coordinates and:
r (Distance), θ (whole circle bearing) for polar coordinates.

A5-2-2 The Importance of the SIGN of the Rectangular Coordinates

It is imperative that you maintain the SIGN of the N and E in the rectangular coordinates. The sign is necessary to produce the required ATN2() angle, and vital to produce the ATAN() angle. Especially for the ATAN, because the answer; positive in two, negative in two quadrants, is the angle referenced the North/South axis. Combined with the SIGN of the latitude difference (ΔN or Δy), the BEARING of the vector can be ascertained. Refer to Section 4.3.1 Manipulating Vectors for revision.

ATAN() function marked as \tan^{-1} (SHIFT **tan^F**):

In using the ATAN() function examine the SIGN of the δN .

If δN is POSITIVE the ANGLE is in quadrants I and IV. If necessary ADD 360°.

If δN is NEGATIVE, the angle is in quadrants II or III, so ADD 180°.

ATAN2() function.

The returned angle (stored in memory F (RCL **tan^F**)) is either positive, (0 clockwise to 180°) or negative (0 anticlockwise to -180°)

if positive it is the BEARING or,

if negative, the BEARING is $360^\circ + \text{RCL } \text{tan}^{\text{F}}$.

A5-3 Converting between Polar and Rectangular Coordinates using Function Keys

A5-3-1 Trigonometric Conversion to Rectangular Coordinates

The examples in this manual, converting bearing/distance to dE, dN via the standard method:

$$dE = \text{distance} \times \text{SIN}(\text{brg})$$

$$dN = \text{distance} \times \text{COS}(\text{brg})$$

is tedious and error prone from having to key in the distance and bearing twice, and record each answer.

A5-3-2 Trigonometric Conversion using the **Rec(** Function Key

To convert from the polar BRG/DIST coordinates to dE, dN you should make use of the **Rec(** function; (SHIFT **Pol(**). However, there are a couple of gotchas with these two functions:

1. the input is in the sequence **r,θ**, i.e. distance, bearing. Note the comma separator.
2. the answers, dE and dN, are held in two memory locations, E and F.

cos^E holds the dN and **tan^F** holds dE. The display show the dN value (memory E)

dE is accessed by recalling memory F (RCL **tan^F**)

dN is accessed by recalling memory E (RCL **cos^E**)

Example: Convert the following BRG/DIST to dE, dN:

BRG 125° 15' 20", distance 102.536m.

Conventionally:

$$102.536 \times \sin 125^\circ 15' 20'' = 83.729420, \text{ dE, then re-keying for dN}$$

$$102.536 \times \cos 125^\circ 15' 20'' = -59.786278, \text{ dN.}$$

Note the requirement to repeatedly key the same data.

Using **Rec()**: input the distance, the comma, then the BRG in either DMS, using the **°"** key for each value of D, M and S; or use decimal degrees.

There is no need to close the parenthesis **)** key before enter, **=**:

$$\text{Rec}(102.536, 125^\circ 15' 20'' = -59.786278, \text{ dN, then, to retrieve dE}$$

$$\text{RCL } \tan^F = 83.729420, \text{ dE.}$$

dN and dE will be retained in **cos^F** and **tan^F** until overwritten.

A5-4 Converting between Rectangular and Polar Coordinates Using Function Keys

A5-4-1 Trigonometric Conversion to Polar Coordinates

The examples in this manual, converting dE, dN to bearing/distance via the standard,

$\theta = \text{Atan}(\tan^{-1})(\text{dE}/\text{dN})$, converted to a whole circle bearing in the correct quadrant.

$r = \text{Sqrt}(\sqrt{(\text{dE}^2 + \text{dN}^2)})$, Pythagoras, is also tedious and error prone from having to key in the dE and dN twice, and record each answer.

Conventionally we calculate and record the dE and dN between two points, then go ahead through a number of steps to get the result.

Let's try an example and attack it three ways: twice conventionally, then using the **Pol()** function key.

$$\begin{aligned} E_A &= 135.872 & N_A &= 7450.124 \\ E_B &= 125.126 & N_B &= 7540.067 \\ dE_{AB} &= -10.746 & dN_{AB} &= 89.943. \end{aligned}$$

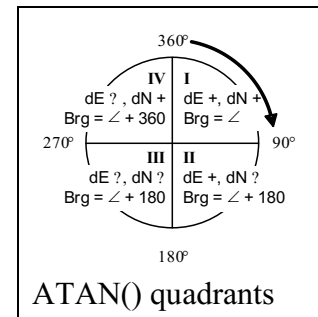

Finding the tangent,

$$\text{using } -10.746 \div 89.943 = -0.119476,$$

$$\text{find ATAN(), } \tan^{-1} \text{Ans} = -6.813156,$$

it is in quadrant 4. (dE -ve, dN +ve), so add 360:

$$360 + \text{Ans} = 353.186844 \quad \text{°"} \quad 353^\circ 11' 12.6$$

Then, using Pythagoras for distance, using the **x²** key and the **√** keys

$$(-10.746)^2 + 89.943^2 = 8205.219765. \text{ (Note the use of parentheses for the negative dE}_{AB}\text{).}$$

$$\sqrt{\text{Ans}} = 90.5827 \text{ (Note: } -10.746^2 + 89.943^2 = 7974.266733;$$

$$\text{and } \sqrt{\text{Ans}} = 89.2987\text{). BIMDAS at work.}$$

Shortcutting it a bit, and knowing the angle is in quadrant 4 (+360)

$$360 + \tan^{-1}(-10.746 \div 89.943) = 353.186844 \quad \text{°"} \quad 353^\circ 11' 12.6$$

$$\text{Straight in to Pythagoras: } \sqrt{((-10.746)^2 + 89.943^2)} = 90.5827$$

or, shorter (?) by entering the E and N values directly

$$360 + \tan^{-1}((125.126 - 135.872) \div (7540.067 - 7450.124)) =$$

$$353.186844 \quad \text{°"} \quad 353^\circ 11' 12.6$$

$$\sqrt{((125.126 - 135.872)^2 + (7540.067 - 7450.124)^2)} = 90.5827$$

A5-4-2 Trigonometric Conversion Using the **Pol()** Function Key

Using the **Pol()** function key: – converting rectangular(dN, dE) to polar (r,θ)

Note: we have to input dN, then dE,

Pol (89.943 **↓** -10.746) **=** **90.5827**, distance, r,
then, to retrieve bearing, θ,

RCL **tan^F** F= -6.813156, bearing, θ, is negative,
this means θ is in the western hemisphere, add 360;

360+ RCL **tan^F** **=** **353.186844** **0°”** **353°11’12.6**

The **Pol()** function uses the ATN2(dN,dE) function, providing a bearing between

0 and +180 clockwise for quadrants 1 and 2 and

0 and -180 anti-clockwise for quadrants 4 and 3.

Thus a negative result requires the addition of 360°.

r and θ will be retained in **cos^E** and **tan^F** until overwritten.

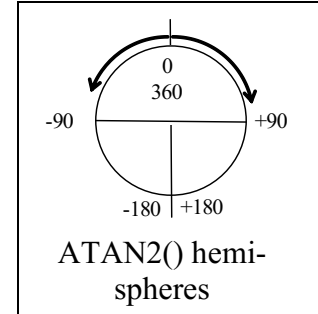

A5-4-3 The ATAN2() Function in Spreadsheets.

ATAN2(dN,dE) is a handy function in Excel, note the order: dN, dE the best way to get decimal degrees in the correct bearing is to use

=MOD(DEGREES(ATAN2(dN, dE)),360).

A5-5 Using the **M+** Key for Accumulate Operations

A few sets of calculations lend themselves to the accumulation of results.

- Rise & Fall levelling,
- Areas by coordinate cross multiplication.

Using the example on Table A3-5.1,

RL_{BM} = 10.125

Load the memory with RL_{BM}:

10.125 **STO** **M+**

this puts 10.125 in M+

Get the first rise/fall:

1.742 - 1.628 = **0.114** (note rise)

M+ puts result in M+ (don't use the = key).

Use RCL **M+** M= **10.239** to see RL

Next rise/fall:

1.628 - 1.205 = **0.423** (note rise)

M+ puts result in M+ (don't use the = key).

Use RCL **M+** M= **10.662** to see RL.

Next rise/fall:

1.205 - 1.1.585 = **-0.380**

(note **fall**) **M+** puts result in M+ (don't use the = key)

Use RCL **M+** M= **10.282** to see RL..

The **M+** key is a tricky beast to get accustomed to, but may be useful for chain calculations.

Table A3-5.1

BS	IS	FS	Rise	Fall	RL
1.742				BM	10.125
	1.628		0.114		10.239
	1.205		0.423		10.662
	1.585			0.380	10.282
	1.625			0.040	10.242
	1.550		0.075		10.317
1.580		1.522	0.028		10.345
	1.635			0.055	10.290
	1.640			0.005	10.285
	1.825			0.185	10.100
	1.745		0.080		10.180
		1.892		0.147	10.033
Sum		Sum	Sum	Sum	
3.322		3.414	0.720	0.812	
Σ BS - Σ FS			Σ RiseS- Σ Falls		
	-0.092		Diff =	-0.092	-0.092

A5-6 Statistics, Mean and Standard Deviations

During the field practical sessions there are occasions when the mean of a set of observations is required. A good check is to evaluate the standard deviation (SD) of the set to form an opinion of the acceptability of the observation, a form of blunder detection.

Field practical 4, establishment of control, produces four horizontal, and four vertical, the distances for each leg of the control traverse. A check of the mean and the SD may be warranted to guard against mistakes.

The easiest process for using the statistics functions would require that you calculate the horizontal and vertical distances of each observation using the Rec(function to convert zenith angle (ZA) and slope distance. If both FL and FR observations are taken, then the absolute value need to be assigned to the horizontal distance, otherwise the FR distance will be negative.

$$(\sin(ZA = 90) = +1, \sin(ZA = 270) = -1).$$

Using $\text{Rec}(125.257, 89^\circ 30' 45'' = 1.066, \text{RCL } \tan^{\text{F}} = 125.252466$ and making a table for the four observations, the SD mode can be then be initiated.

Set SD mode: **MODE** **2** **=**.

Clear registers (Clr):

CLR (**SHIFT** **MODE** **1** **=**).

Stat clear **=** 0.0000.

The **M+** key acts as the **DT** key. $n =$ input count.

125.2525 **M+** $n=1.00$

125.2544 **M+** $n=2.00$

125.2514 **M+** $n=3.00$

125.2503 **M+** $n=4.00$

Obs	ZA	S dist	H dist	V dist
A – B FL	89° 30' 45"	125.257	125.2525	+1.066
A – B FR	270° 29' 30"	125.259	125.2544	+1.075
B – A FL	90° 29' 30"	125.256	125.2514	-1.075
B – A FR	269° 30' 15"	125.255	125.2503	-1.084

Find mean: S-VAR (**SHIFT** **2**) **1** **=** \bar{x} 125.2527

Find standard deviation of mean: S-VAR (**SHIFT** **2**) **2** **=** $x\sigma n$ 0.0015

This method will help catch number transposition blunders, although the booker must always be alert for anomalies in the data recording.

A5-7 Concluding remarks

It is hoped that this expansion on the capabilities of the HP 10S+ calculator, mandated for some courses, will be of use in allowing you to explore its vector capabilities.

A5-8 References Appendix A5

1. Hewlett-Packard, HP 10s+ Scientific Calculator User Guide, Hewlett-Packard Development Company, 2012.

INDEX

3
3D positioning 148

A

Angles 79
Angular Measurements 68
Angular misclose 80, 86
apparent strike 103
Area 40
Area Computations 82
Area Levelling 22
Atmospheric Effects 67
atmospheric errors 155

B

Backsight 18
batter slope 35, 36, 43
bearing 70, 123, 162
Bench Mark (BM) 10, 19
benches 43
Berm width 44
block volume 48
blunders 5, 76, 94
Bowditch Adjustment 81
Bowditch method 158

C

Cadastral surveying 1
cadastral surveys 5
centre line 124
Chainage 119, 128
change plate 18
change point 19
chord deflection angle 118
Chord length 139
Chord offsets 123
chords 129
circular level 57
collimation axis 56
collimation error 17
conformal transformation 172
contour 31, 50
control point 77, 123
Control surveying 2
coordinate misclose 85
Coordinate transformation 169
coordinates 2, 70, 119
Crest curves 133
cross section 9, 32, 34
cut 43

D

Datum 169
deflection angle 122, 129
Depth to seam 108

Design parameters 124
design speed 131
differential levelling 18, 24
Digital Elevation Model (DEM) 31, 34
Digital Terrain Model (DTM) 31, 34
Dip 103
dipping plane 103
direction 71
distance 70, 79, 123, 162
Distance measurements 6, 55, 62
drill hole 108

E

Earth curvature 93
earthwork 9
Eastings 77, 81
electromagnetic distance
measurement (EDM) 3, 6, 55, 93
Elevation 10
ellipsoid 12
ellipsoidal heights 12
Embankment 33
Engineering design plans 160
Engineering surveying 1
Errors in GPS 151
errors in levelling 28

F

Face Left (FL) 79, 93
Face Right 69, 93
field book 47
Field notes 5, 79, 157, 159
Field reduction 79
fill 43
formation centre line 35
Formation level 32

G

Galileo 147
Geodetic surveying 3
global navigation satellite system
(GNSS) 2, 77, 147
GLONASS s 147
GNSS 12
Good Surveying Practices 12
GPS 35, 147
gradient 33
gross errors 5

H

Haul road 127
Height 10, 31, 170
Height of Collimation method 19, 26
Horizontal alignment 115
horizontal angles 110

- Horizontal Control 35, 77, 157, 158, 162
Horizontal curve 115, 145
horizontal line of sight 19
Horizontal plane 9
horizontal reading 69
Hydrographic surveying 2
- I**
inclined plane 110
Intersection 163
intersection point 120
- J**
Join Calculation 70
- L**
laser scanners 57
Least Squares 179
Level surface 9
levelling 9, 166
Linear measurements 6
local gravity vector 2
Longitudinal section 32
- M**
Mean Sea Level 9
Mine surveying 1
- N**
Northings 77, 81
- O**
open pit mining 157
ormation width 32
orthometric height 24
Overtaking sight distance 144
- P**
parabolic curve 131
parallax 18
Photogrammetric surveying 1
plane surveying 2
planimeter 51
plans 157, 159
Polar Calculation 70, 74
Prism constant 64
project 159
Project Engineer 159
Projection 169
- R**
Radiation 164
Ramp width 43
ramps 44
Random errors 6
reduced level (RL) 16
reflected laser beam 55
Refractive index 64
- relief 31
Resection 165, 186
Rise and Fall method 19
rules of levelling 18
rural road 142
- S**
sag curve 133, 141
scale 31
Scale Error 66
scale factor 75
Seam thickness 108
Set out Plans 160
Setting out 157
slope 141
spot heights 31
Standard Survey Marks (SSMs) 79
stockpile 52
Stopping sight distance 144
straight lines 117
Strike 103
strike line 103
Surveying 1
Systematic (deterministic) errors 6
Systematic errors 28
- T**
Tangent offsets 122
Topographic surveying 1
Total Station 3, 9, 55
Total Station differential levelling 93
transitional curves 115
trapezium 47
traverse 80, 162
Traverse adjustment 80
Traverse procedure 78
Traversing 6
Trigonometric heighting 166
trigonometric levelling 9, 93
trigonometrical formulae 1
trunnion axis 56
turning point 19
two peg test 16
- V**
vertical axis 56
Vertical circle 94
Vertical control 35, 158, 166
vertical curves 131
Vertical datum 9
vertical direction 2
Vertical distances 62
Vertical line 9
vertical sections 31
volume 9, 42, 50, 77